

Basic Parameters

Model	GWH09AGAXB-K6DNA2C		
Product Code	-	CB543012000	
Power Supply	Rated Voltage	V~	220-240
	Rated Frequency	Hz	50
	Phases	-	1
Power Supply Mode	-	Outdoor	
Cooling Capacity	W	2500	
Heating Capacity	W	2800	
Cooling Power Input	W	660	
Heating Power Input	W	700	
Cooling Current Input	A	3.1	
Heating Current Input	A	3.2	
Rated Input	W	1500	
Rated Cooling Current	A	6	
Rated Heating Current	A	7.5	
Air Flow Volume	m ³ /h	500/470/430/390/320/270/250	
Dehumidifying Volume	L/h	0.60	
EER	W/W	3.79	
COP	W/W	4	
SEER	-	6.8	
SCOP (Average/Warmer/Colder)	-	4.1/5.1/-	
Application Area	m ²	10-16	

Indoor Unit Parameters

Indoor Unit Model	GWH09AGAXB-K6DNA2C/I		
Indoor Unit Product Code	-	CB543N12000	
Fan Type	-	Cross-flow	
Fan Diameter Length (D×L)	mm	Φ93×505	
Cooling Speed	r/min	1300/1200/1120/1050/920/800/750	
Heating Speed	r/min	1300/1200/1120/1050/950/850/800	
Fan Motor Power Output	W	20	
Fan Motor RLA	A	0.22	
Fan Motor Capacitor	μF	1	
Evaporator Form	-	Aluminum Fin-copper Tube	
Evaporator Pipe Diameter	mm	Φ5	
Evaporator Row-fin Gap	mm	2-1.4	
Evaporator Coil Length (L×D×W)	mm	509×22.8×266.7	
Swing Motor Model	-	MP24HF/MP24BA/MP24AK	MP24BA/MP24AK
Swing Motor Power Output	W	1.5/1.5/1.5	1.5/1.5
Fuse Current	A	3.15	
Sound Pressure Level	dB (A)	Cooling:38/36/34/32/28/25/22 Heating:38/36/34/32/29/25/23	
Sound Power Level	dB (A)	Cooling:55/48/46/44/40/37/34 Heating:55/48/46/44/41/37/35	
Dimension (W×H×D)	mm	704X260X185	
Dimension of Carton Box (L×W×H)	mm	748X316X247	
Dimension of Package (L×W×H)	mm	753X332X258	
Net Weight	kg	7.5	
Gross Weight	kg	9	

Outdoor Unit Parameters

Outdoor Unit Model	-	GWH09AWAXB-K6DNA1C/O
Outdoor Unit Product Code	-	CB603W05100
Compressor Manufacturer	-	ZHUHAI LANDA COMPRESSOR CO., LTD.
Compressor Model	-	QXF-N082zC170
Compressor Oil	-	RB68GX or equivalent
Compressor Type	-	Rotary
Compressor LRA.	A	/
Compressor RLA	A	3.4
Compressor Power Input	W	630
Compressor Overload Protector	-	/
Throttling Method	-	Capillary
Set Temperature Range	°C	16~30
Cooling Operation Ambient Temperature Range	°C	-15~50
Heating Operation Ambient Temperature Range	°C	-15~30
Condenser Form	-	Aluminum Fin-copper Tube
Condenser Pipe Diameter	mm	Φ7
Condenser Rows-fin Gap	mm	1-1.2
Condenser Coil Length (L×D×W)	mm	666×19.05×527
Fan Motor Speed	rpm	850
Fan Motor Power Output	W	35
Fan Motor RLA	A	0.4
Fan Motor Capacitor	μF	/
Outdoor Unit Air Flow Volume	m ³ /h	1950
Fan Type	-	Axial-flow

Fan Diameter	mm	Φ400
Defrosting Method	-	Automatic Defrosting
Climate Type	-	T1
Isolation	-	I
Moisture Protection	-	IPX4
Permissible Excessive Operating Pressure for the Discharge Side	MPa	4.3
Permissible Excessive Operating Pressure for the Suction Side	MPa	2.5
Sound Pressure Level	dB (A)	51
Sound Power Level	dB (A)	61
Dimension (W×H×D)	mm	732X555X330
Dimension of Carton Box (L×W×H)	mm	791X373X590
Dimension of Package (L×W×H)	mm	794X376X615
Net Weight	kg	23.5
Gross Weight	kg	26
Refrigerant	-	R32
Refrigerant Charge	kg	0.48

Connection Pipe Parameters

Connection Pipe Length	m	5
Connection Pipe Gas Additional Charge	g/m	16
Outer Diameter Liquid Pipe	inch	1/4
Outer Diameter Gas Pipe	inch	3/8
Max Distance Height	m	10
Max Distance Length	m	15

Note: The connection pipe applies metric diameter.

The above data is subject to change without notice. Please refer to the nameplate of the unit.

3.2 Capacity Variation Ratio According to Temperature

The models for 07K ~ 24K with heating operation ambient temperature range of -15°C~24°C

Cooling ►

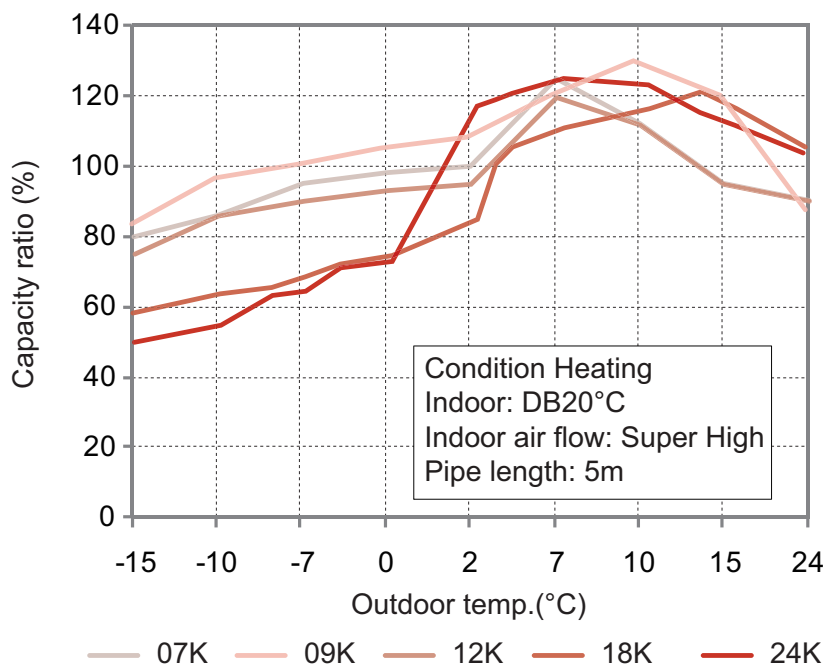
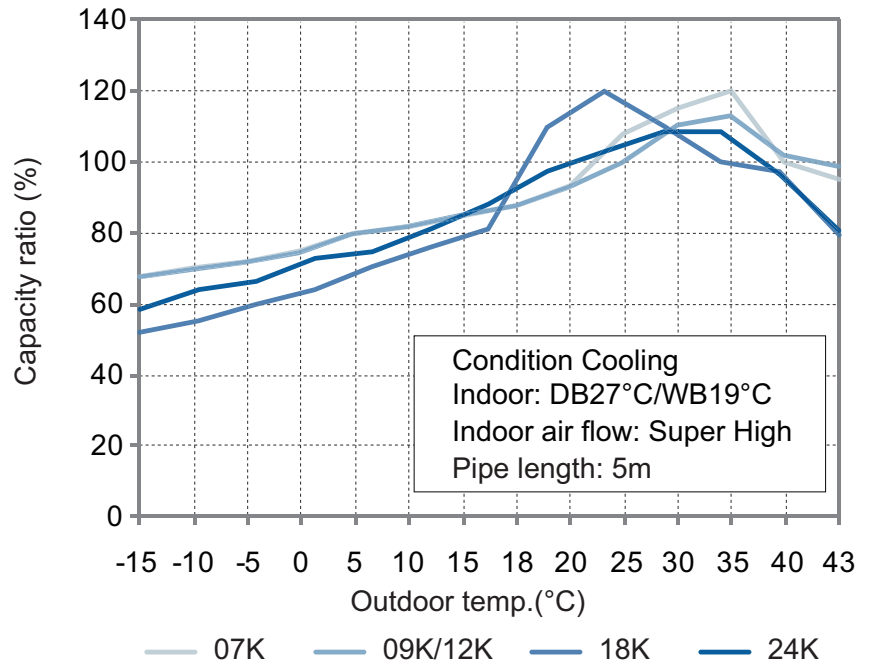

◀ Heating

The models for 09K with heating operation ambient temperature range of -22°C~24°C

Cooling ►

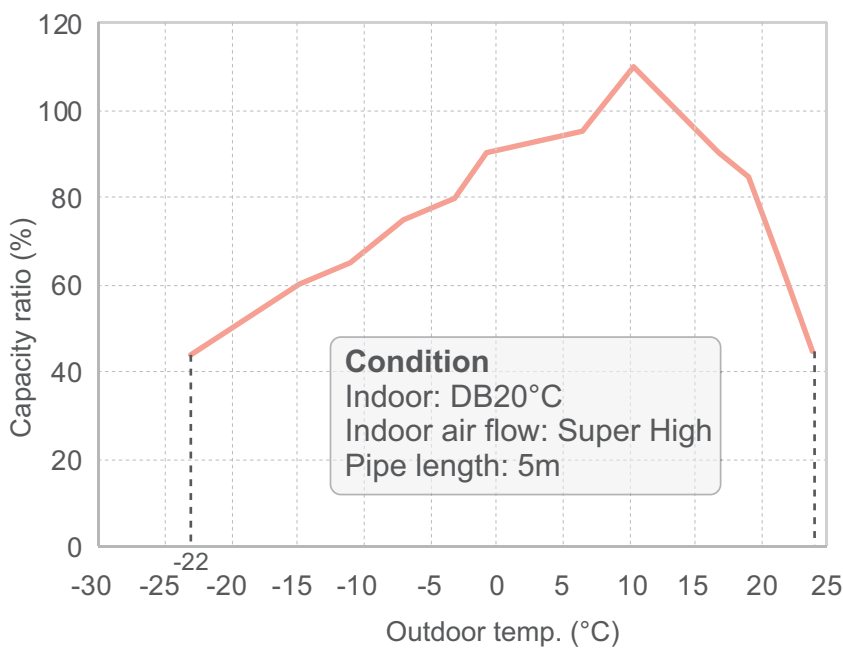
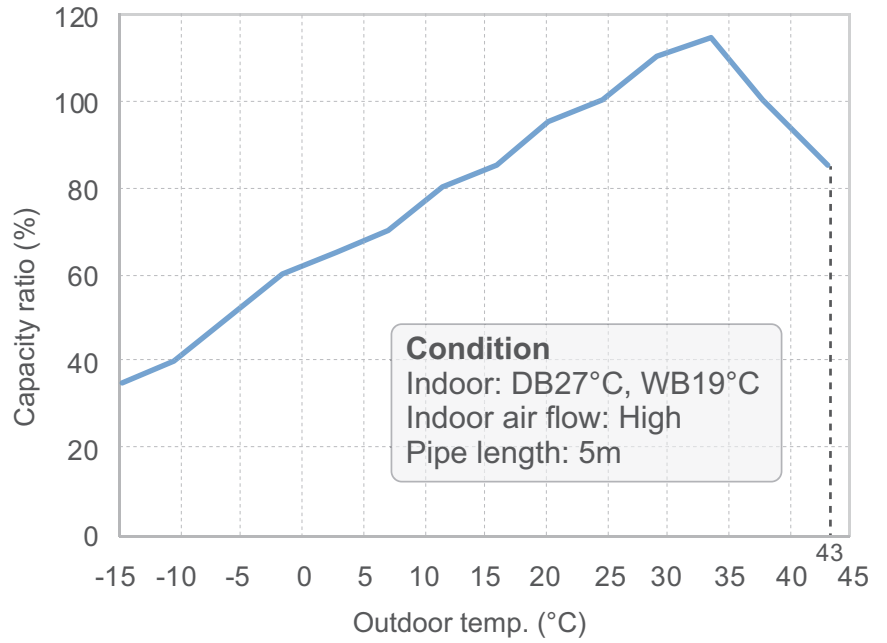

◀ Heating

The models for 09K ~ 24K with heating operation ambient temperature range of -25°C~30°C

Cooling ▶

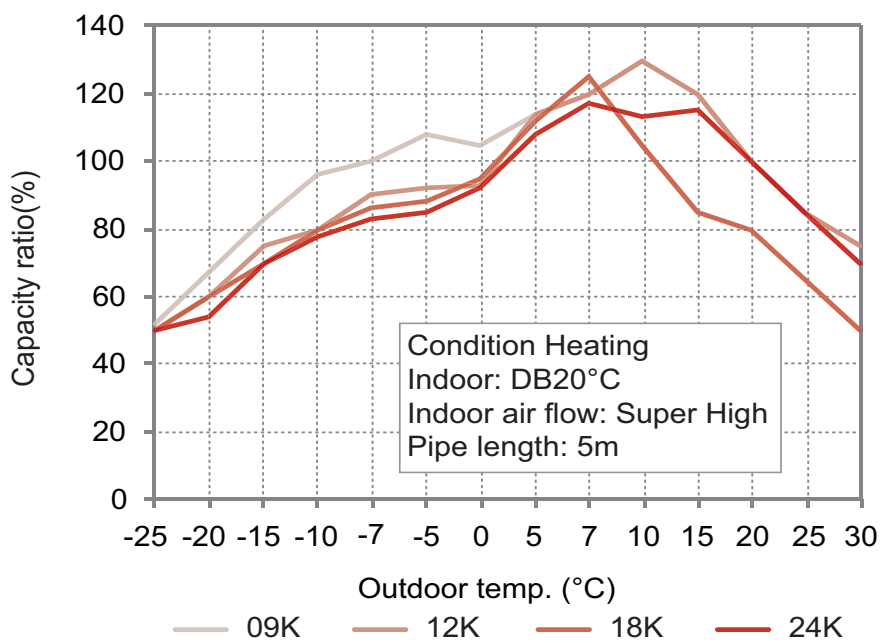
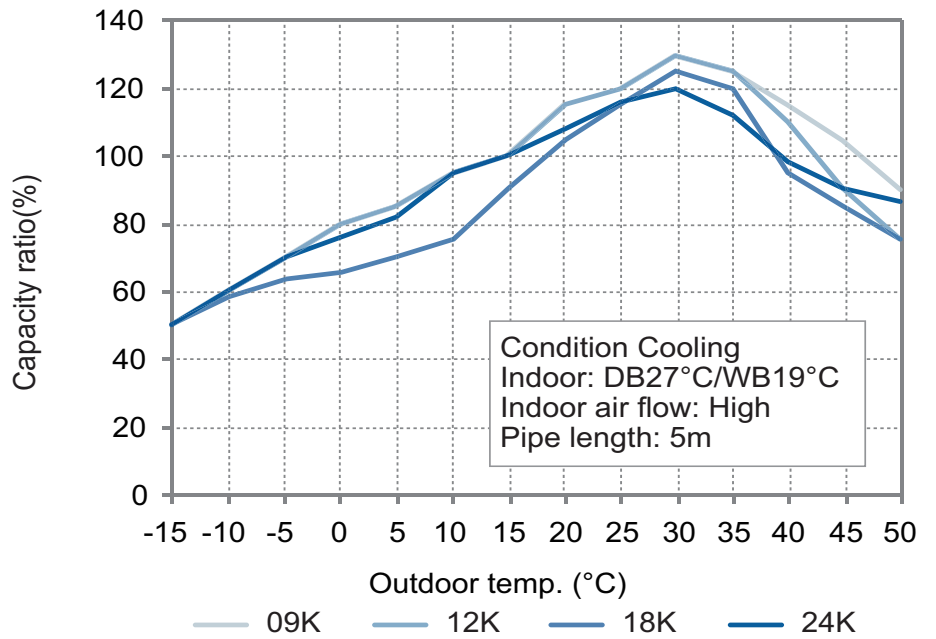

◀ **Heating**

The models for 09K ~ 24K with heating operation ambient temperature range of -15°C~30°C

Cooling ▶

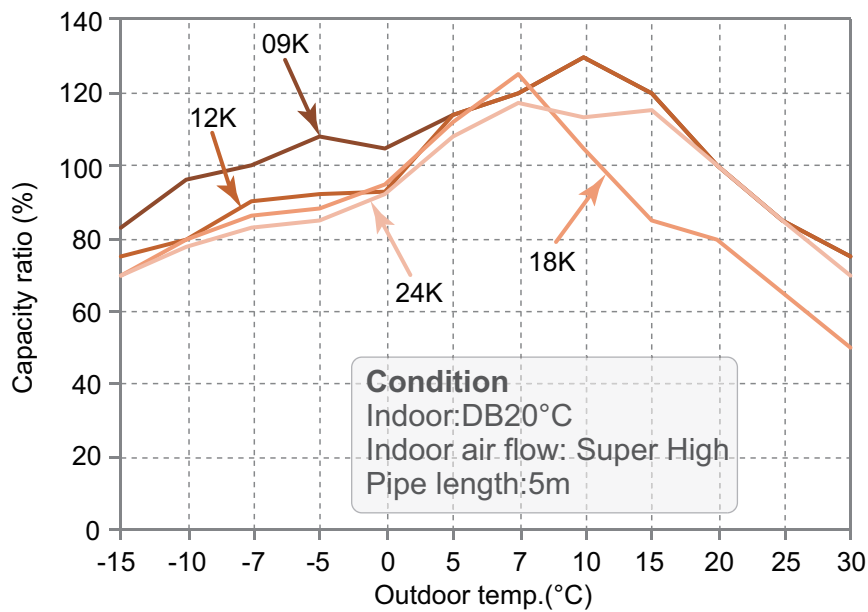
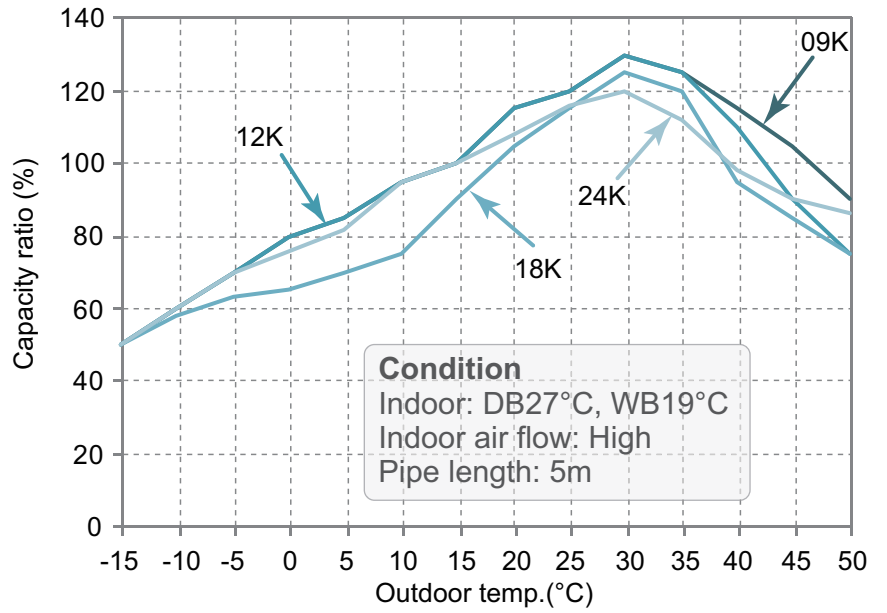

◀ **Heating**

4. Outline Dimension Diagram

4.1 Indoor Unit

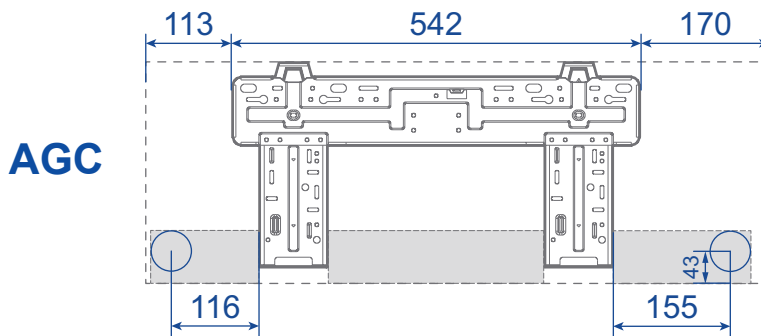
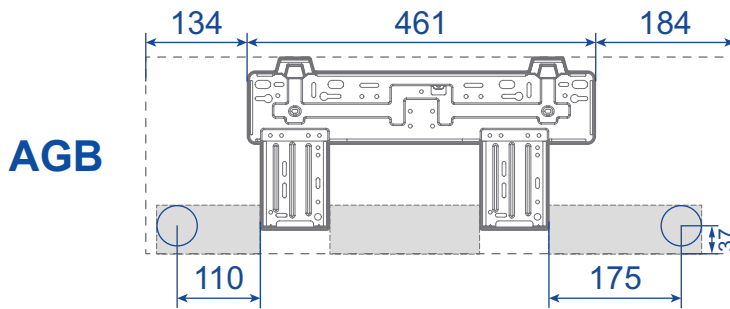
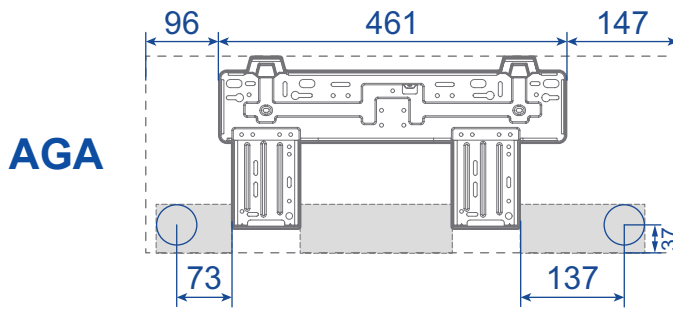
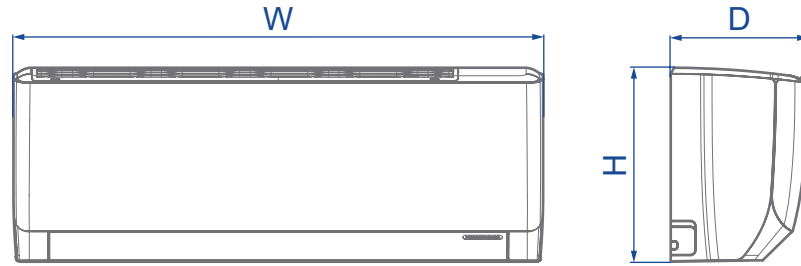

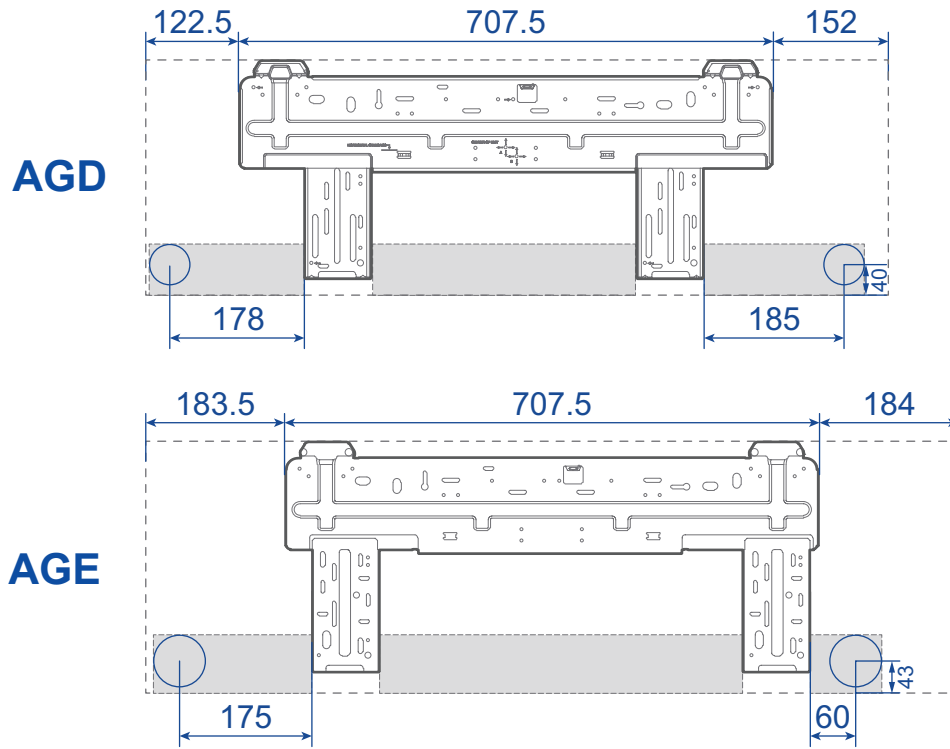

Note: Choose the diameter of piping hole according to the pipe-holesleeve.

Unit: mm

Indoor Unit Model	W	H	D
AGA	704	260	185
AGB	779	260	185
AGC	825	293	196
AGD	982	311	221
AGE	1075	333	246

4.2 Outdoor Unit

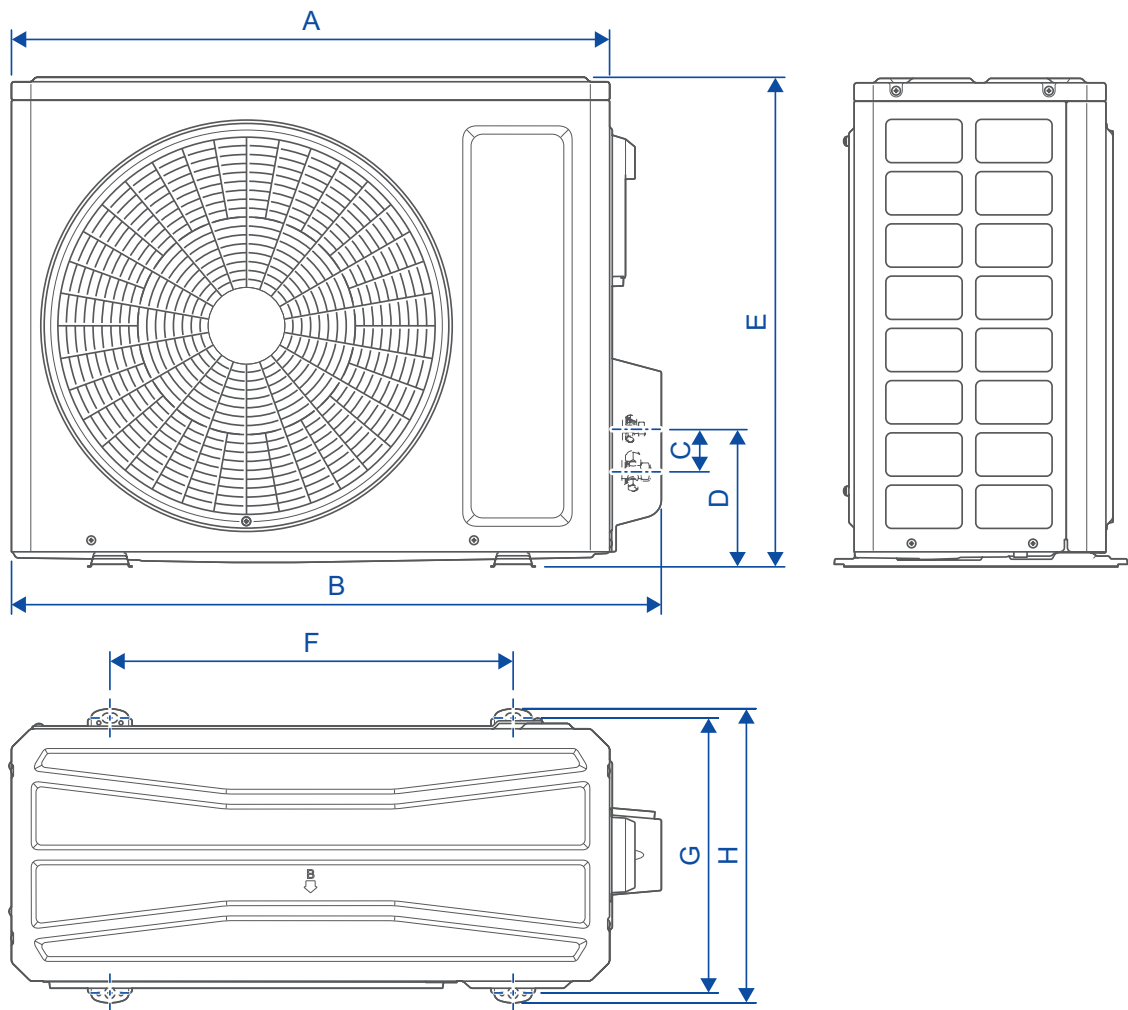

NOTE: The appearance of outdoor unit is for reference only.

Unit: mm

Outdoor Unit Model	A	B	C	D	E	F	G	H
GWH07AGA-K6DNA1A/O	650	710	65	158.8	450	430	271	293
GWH09ACCXB-K6DNA1G/O GWH09AFC-K6DNA2F/O GWH09AGAXB-K6DNA1B/O GWH09AGBXB-K6DNA1A/O GWH09AGBXB-K6DNA1E/O GWH09AGCXB-K6DNA1H/O GWH09AWAXB-K6DNA1C/O GWH09AWBXB-K6DNA1C/O GWH12AFC-K6DNA2F/O GWH12AGBXB-K6DNA1A/O GWH12AGBXB-K6DNA1I/O GWH12AGBXB-K6DNA1Z/O GWH12AGBXB-K6DNA4C/O GWH12AGCXB-K6DNA1A/O GWH12AGCXB-K6DNA1Z/O GWH12ATCXB-K6DNA4G/O GWH12AWBXB-K6DNA3F/O GWH12AWCXB-K6DNA3E/O GWH18AGD-K6DNA1D/O GWH18AGDXB-K6DNA1Z/O	675	732	65	163	555	455	310	330
GWH18AGD-K6DNA1E/O GWH18AGDXD-K6DNA1Z/O GWH12AWCXD-K6DNA1D/O	745	802	65	163	555	513	331	350
GWH24AGD-K6DNA1C/O GWH24AGDXE-K6DNA1E/O GWH24AGDXE-K6DNA1Z/O GWH24AGDXE-K6DNA1A/O	805	873	65	164	555	528	349	376
GWH24AFE-K6DNA2I/O	889	958	65	165.6	660	570	371	402