

## 2. Specifications

Model			GWHD(28)NK600(LC)(LH)	
Product Code			CB228W14800	
Power Supply	Rated Voltage	V~	220-240	
	Rated Frequency	Hz	50	
	Phases		1	
Cooling Capacity		W	8	
Heating Capacity		W	9.5	
Cooling Power Input		W	2.12	
Heating Power Input		W	2.2	
Cooling Current Input		A	9.41	
Heating Current Input		A	9.76	
Rated Power Input		W	3.6	
Rated Current		A	15.97	
EER		W/W	3.77	
COP		W/W	4.32	
Outdoor Unit	Compressor Trademark		ZHUHAI LANDA COMPRESSOR CO., LTD.	
	Compressor Model		QXFS-B212zX070	
	Compressor Refrigerant Oil Type		FW68DA or equivalent	
	Compressor Type		Twin Rotary	
	L.R.A		A	35
	Compressor Rated Load Amp (RLA)		A	/
	Compressor Power Input		W	1887
	Compressor Thermal Protector			KSD115°C HPC115/95U1
	Throttling Method			Electron expansion valve
	Cooling Operation Ambient Temperature Range		°C	-15~43
	Heating Operation Ambient Temperature Range		°C	-22~24
	Condenser Material			Aluminum Fin-copper Tube
	Condenser Pipe Diameter		mm	Φ7.94
	Rows-Fin Gap(mm)		mm	2-1.4
	Coil length (L) X Height (H) X Coil width (W)		mm	851×616×38.1
	Fan Motor Speed (rpm) (H/M/L)		rpm	Cooling: 850 / Heating: 800
	Output of Fan Motor		W	60
	Fan Motor RLA		A	0.426
	Fan Motor Capacitor		μF	/
	Air Flow Volume of Outdoor Unit		m <sup>3</sup> /h	3800
	Fan Type-Piece			Axial-flow
	Fan Diameter-Height		mm	520-154
	Defrosting Method			Automatic Defrosting
	Climate Type			T1
	Isolation			I
	Moisture Protection			IPX4
	Permissible Excessive Operating Pressure for the Discharge Side		MPa	4.3
	Permissible Excessive Operating Pressure for the Suction Side		MPa	2.5
	Dimension (WXDXH)		mm	964×402×660
	Dimension of Carton Box (LXWXH)		mm	1029×453×715
	Dimension of Package (LXWXH)		mm	1032×456×737
Net Weight		kg	51	
Gross Weight		kg	55.5	
Refrigerant			R32	
Refrigerant Charge		kg	1.8	

## 2. Specifications

Outdoor Unit	Cross-sectional Area of Power Cable Conductor	mm <sup>2</sup>	2.5
	Recommended Power Cable(Core)	N	3
	Connection Pipe Connection Method		Flare Connection
	Not Additional Gas Connection Pipe Length	m	40
	Connection Pipe Gas Additional Charge	g/m	20
	Outer Diameter of Liquid Pipe1	inch	1/4
	Outer Diameter of Gas Pipe1	inch	3/8
	Outer Diameter of Liquid Pipe2	inch	1/4
	Outer Diameter of Gas Pipe2	inch	3/8
	Outer Diameter of Liquid Pipe3	inch	1/4
	Outer Diameter of Gas Pipe3	inch	3/8
	Outer Diameter of Liquid Pipe4	inch	1/4
	Outer Diameter of Gas Pipe4	inch	3/8
	Outer Diameter of Liquid Pipe5	inch	/
	Outer Diameter of Gas Pipe5	inch	/
	Connection Pipe Max. Height Distance (Indoor and Indoor)	m	15
	Max. equivalent connection pipe length	m	20
	Connection Pipe Max. Length Distance (total length)	m	70

The above data is subject to change without notice; please refer to the nameplate of the unit.

# 3. Outline Dimension Diagram

GWHD(14)NK600(LC)(LH) GWHD(14)NK600(LC)  
 GWHD(18)NK600(LC)(LH) GWHD(18)NK600(LC)

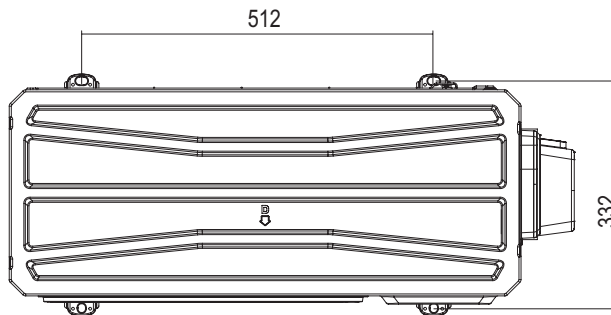
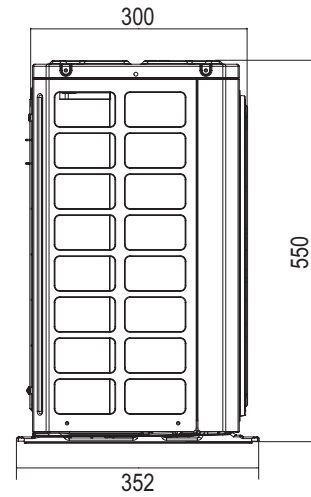
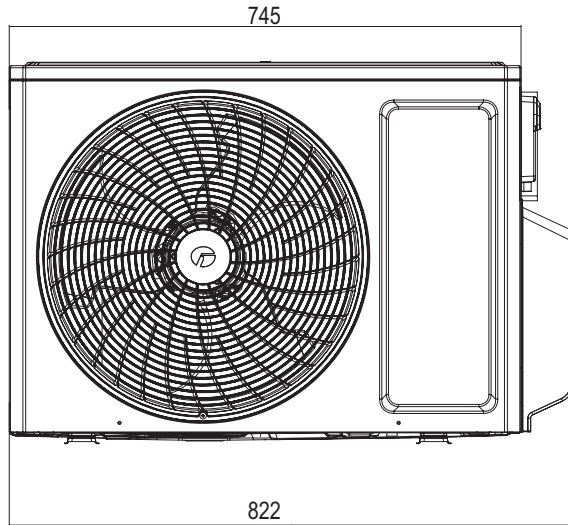

Unit:mm

GWHD(21)NK600(LC)(LH) GWHD(21)NK600(LC)  
 GWHD(24)NK600(LC)(LH) GWHD(24)NK600(LC)  
 GWHD(28)NK600(LC)(LH) GWHD(28)NK600(LC)

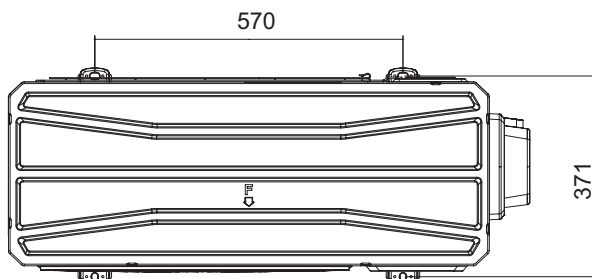
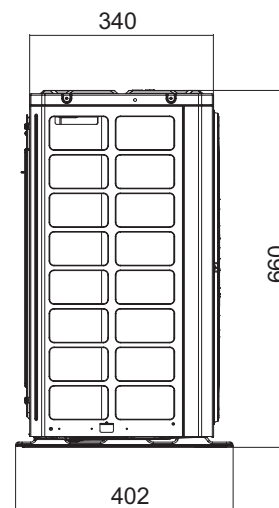
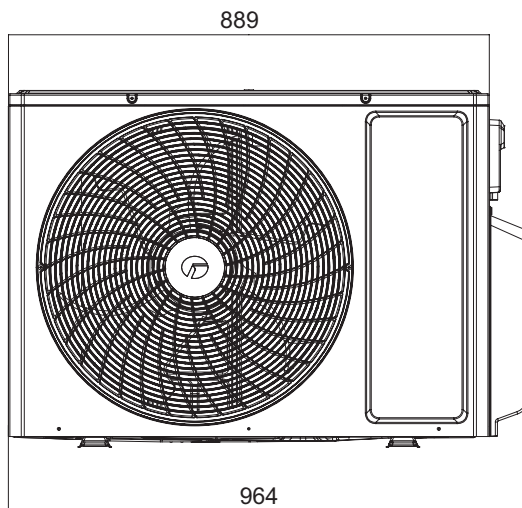

Unit:mm

# 3. Outline Dimension Diagram

GWHD(36)NK600(LC)(LH)    GWHD(36)NK600(LC)  
GWHD(42)NK600(LC)(LH)    GWHD(42)NK600(LC)

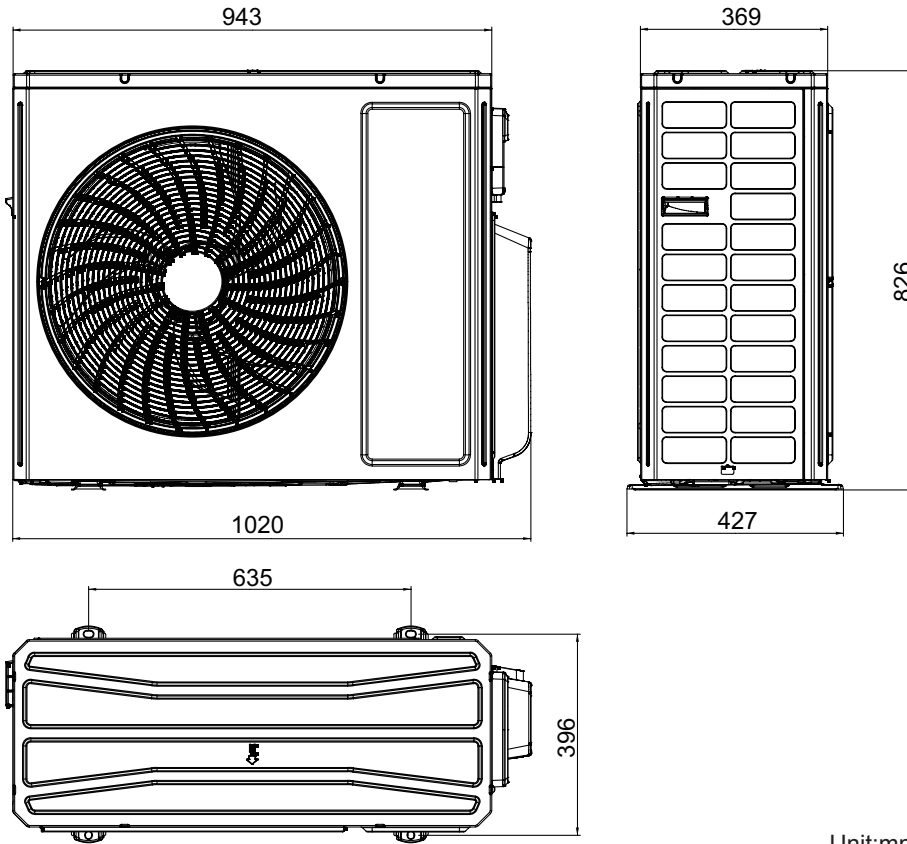

Unit:mm