

Wellis®

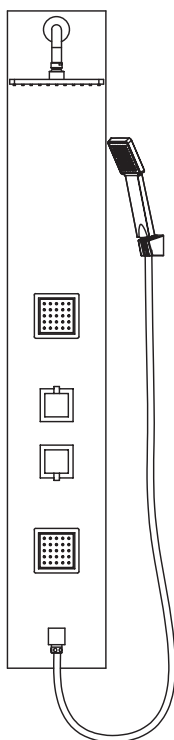

EN

Paloma shower panel
INSTRUCTION MANUAL

DE

Paloma eckdusche panel
BEDIENUNGSANLEITUNG

FR

Panneau de douche Paloma
MODE D'EMPLOI

HU

Paloma sarok zuhanypanel
HASZNÁLATI UTASÍTÁS

RO

Panou de duș pe colț Paloma
INSTRUCȚIUNI DE UTILIZARE

WZ00088

PALOMA

I. Function

1. Shower Head
2. Body jets
3. Diverter
4. Mixer
5. Hand shower

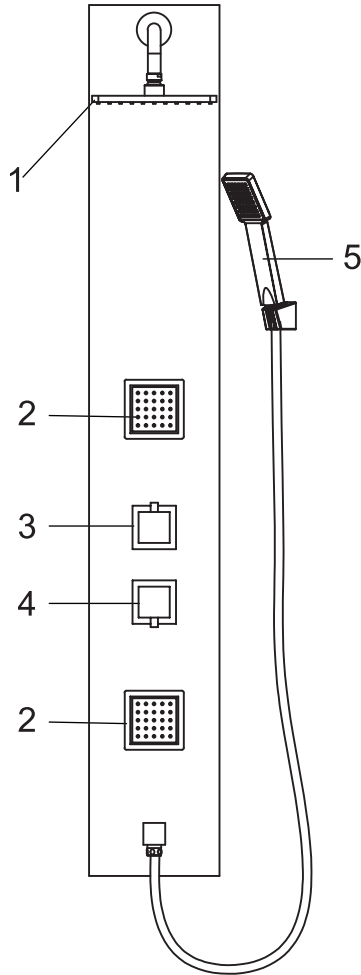

Part list

Please unpack and inspect all packages and components carefully, and make sure they are complete. Examine for shipping damage. If some parts are damaged or missing, notify your dealer immediately.

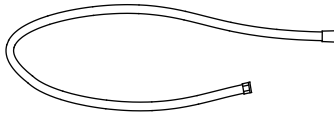
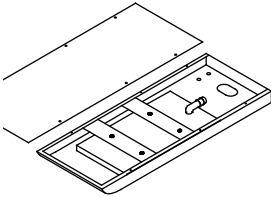

For Installation You may Require the Following Tools

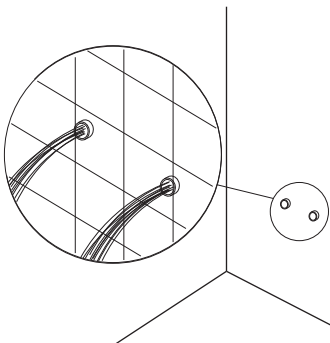
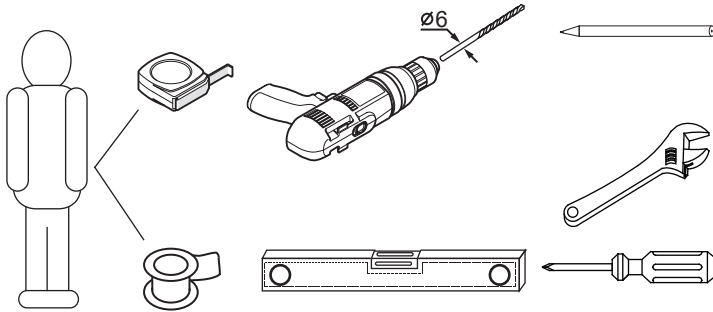

Note!

Before assembly, flush the water supply pipes thoroughly to remove debris (allow the water to run with the main stopcock open for about 3 mins), otherwise dirt particles might affect the function of the shower panel!

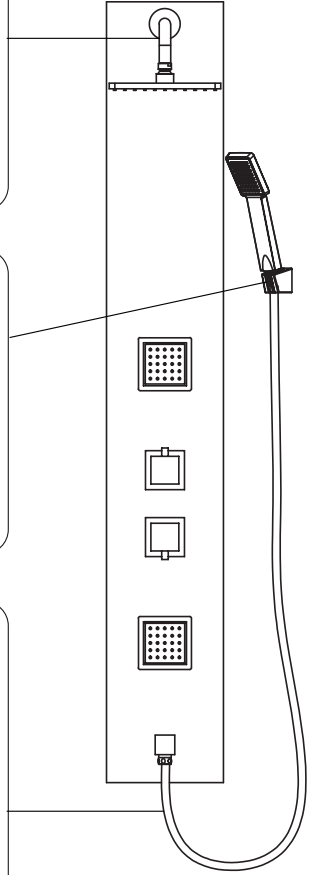
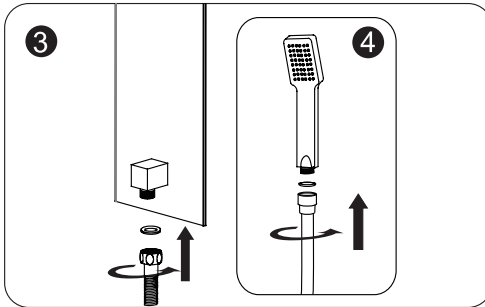
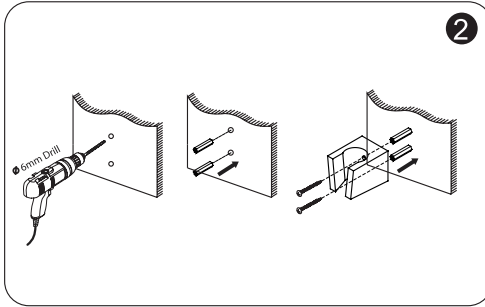
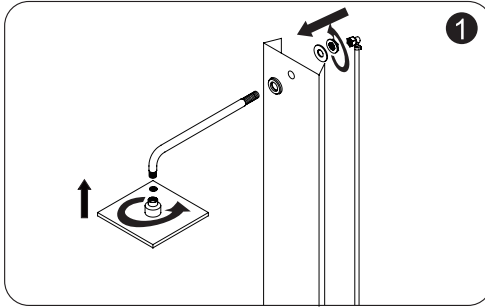

Wall-mounting

NOTE!

Before drilling any holes for fixing your shower panel ensure that there are no hidden cables or pipework within the wall.

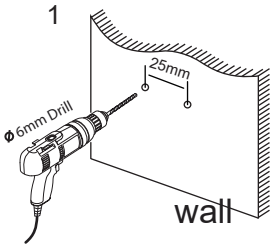

Drill the holes in the wall

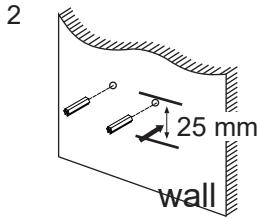

Insert the wall plugs inside the holes

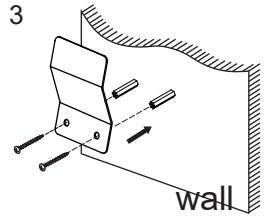

Tighten the screws to the wall with wall mounting brackets

Hang the shower panel on the mounting bracket

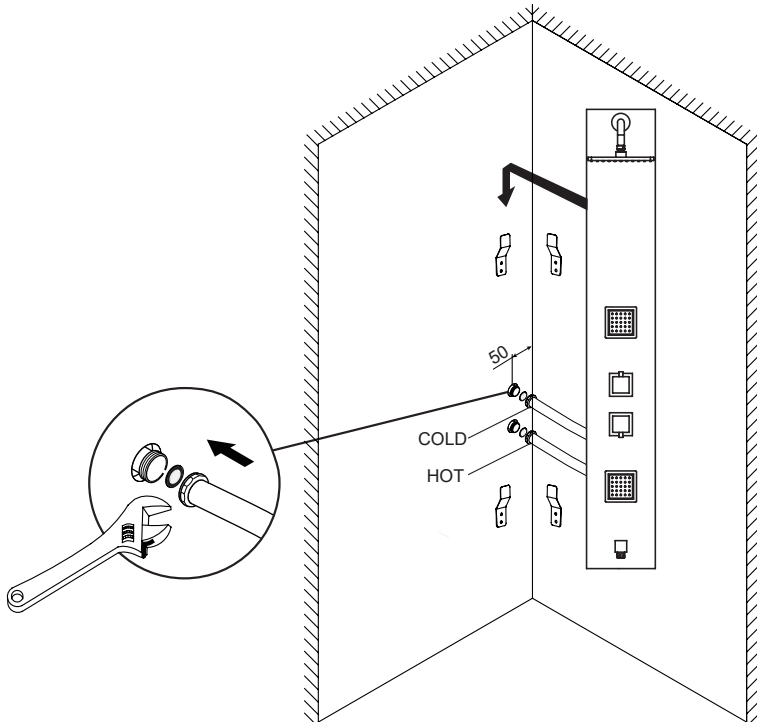

Dimension

Choose a suitable place to install the shower panel, adjust the shower panel's vertical position based on the user's height and your sanitary room. Usually, install the panels at the distance of 210cm from the top to the ground, but you can assemble according to your preference.

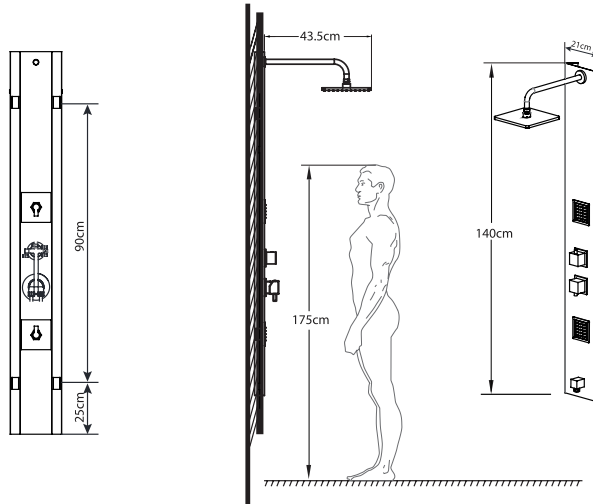

Note!

The height can be altered to suit individual requirements.
The dimensions are for reference only.

Select the shower function required by rotating the control knobs.

Volume and temperature control

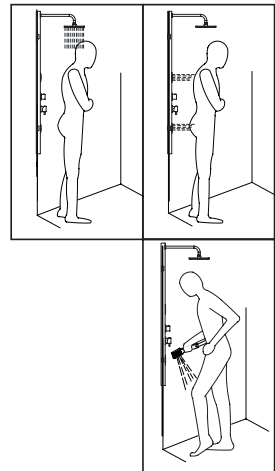
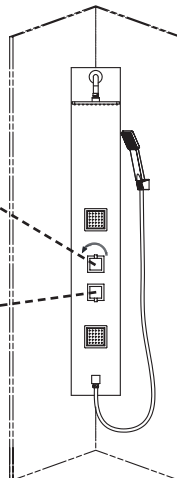

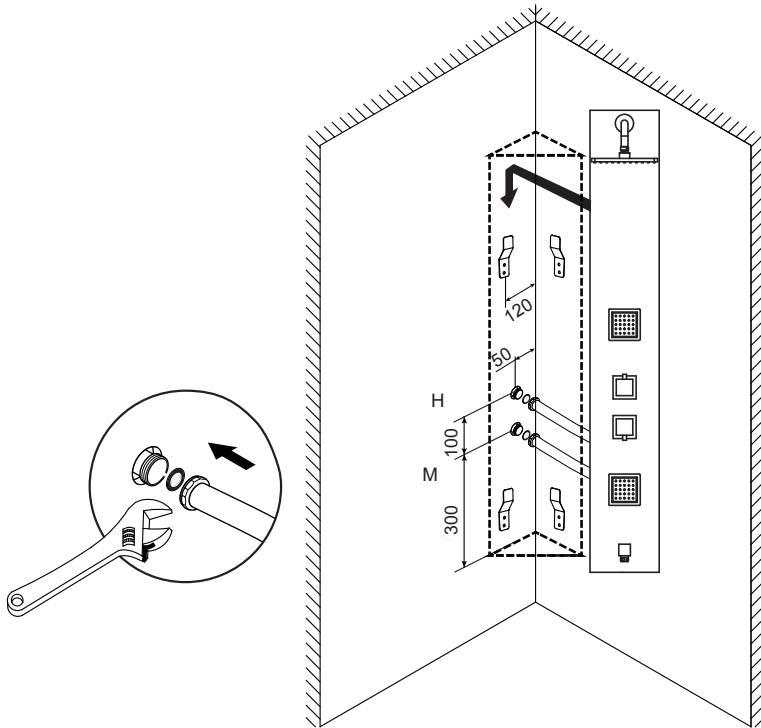

EN

H: Cold water - 1/2" connection

M: Hot water - 1/2" connection

Construction and installation of a floor drain is obligatory!

The dimensions given are indicative only and may vary due to the manufacturing technology of the product. By +/-1 centimetres.

The operation of our shower panels and faucets is designed for the ideal water pressure between 3.5-4.5 bar.

I. Funktion

1. Duschkopf
2. Duschstrahlen
3. Verteiler
4. Mixer
5. Handdusche

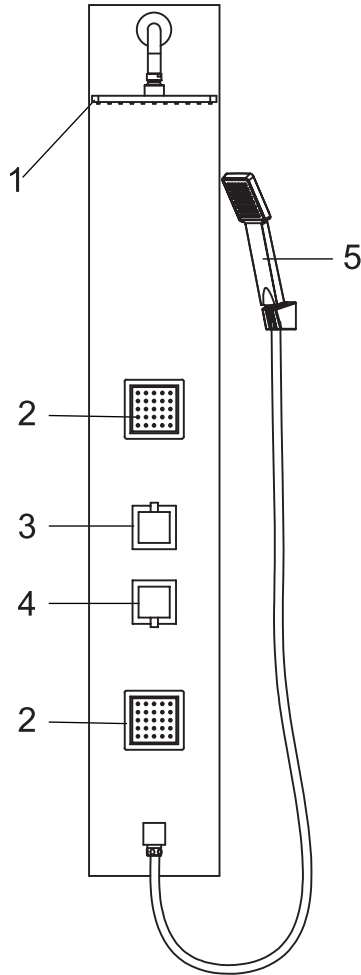

Zubehör Liste

Bitte packen Sie alles aus und inspizieren Sie alle Pakete und Zubehörteile sorgfältig und gehen Sie sicher, dass alles vollständig ist. Überprüfen Sie alles nach Transportschäden. Wenn Teile beschädigt sind oder fehlen, benachrichtigen Sie sofort den Händler.

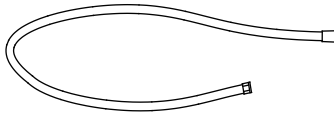
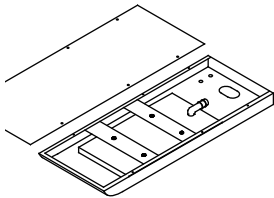
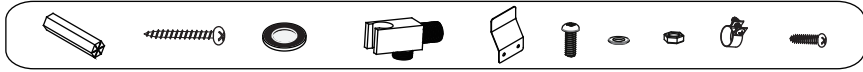

Zur Installation benötigen Sie die folgenden Werkzeuge

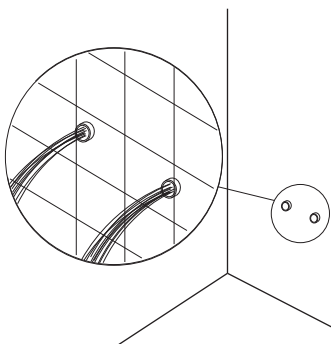
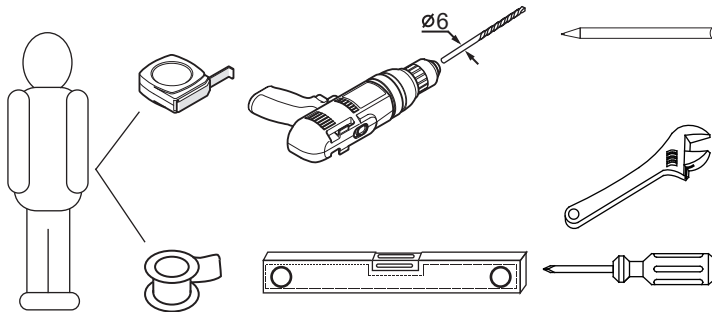

Achtung!

Vor dem Zusammenbau, spülen Sie einmal sorgfältig, um Ablagerungen zu entfernen. (Lassen Sie das Wasser durch den Hauptsperrrhahn mindestens 3 Minuten laufen). Ansonsten können eventuell Dreckpartikel die Funktion der Duschleitung beeinträchtigen!

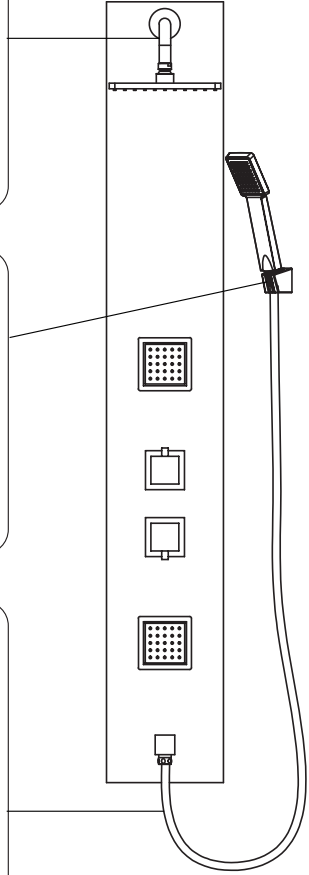
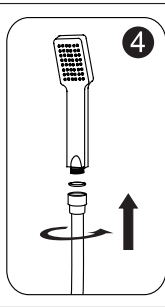
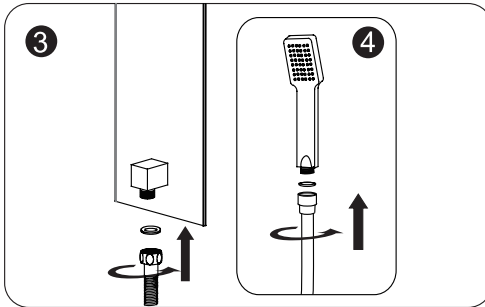
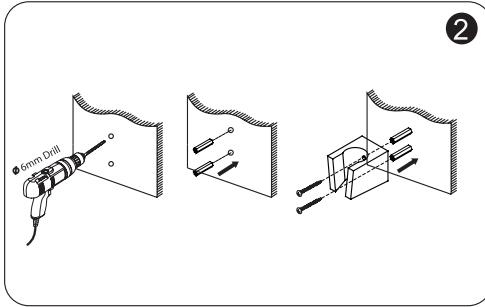
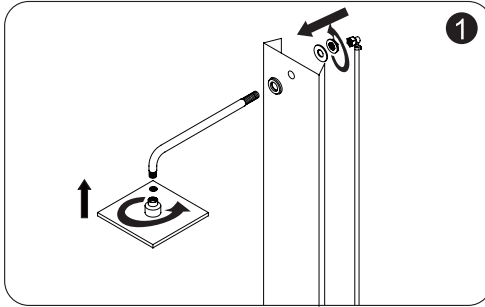

Anbringung an der Wand

Achtung!

Bevor Sie irgendwelche Löcher bohren, um Ihre Dusche anzubringen, vergewissern Sie sich, dass es dort keine versteckten Kabel oder Leitung in der Wand gibt.

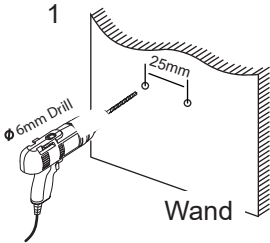

Bohren Sie das Loch in die Wand.

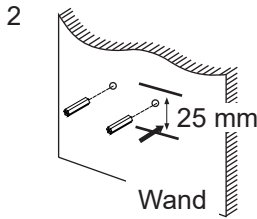

Bohren Sie das Loch in die Wand.

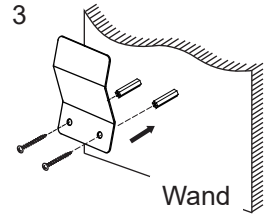

Ziehen Sie die schrauben an der Wand mit den Halterungen an.

Hängen Sie die Duscheleitung auf die Halterungen.

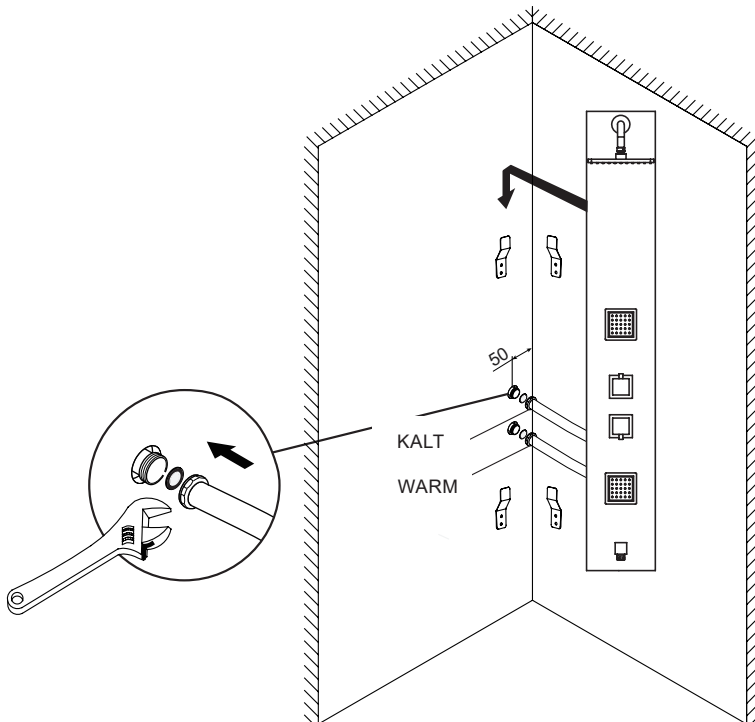

DE Größe

Wählen Sie einen geeigneten Platz, um die Duschkabine zu installieren, passen Sie die Duschleitung vertikale Lage je nach der Nutzergröße und Ihrem Badezimmer an. Normalerweise wird die Leitung mit einer Entfernung von 210cm von Boden befestigt, aber Sie können es je nach Ihrem Belieben aufbauen.

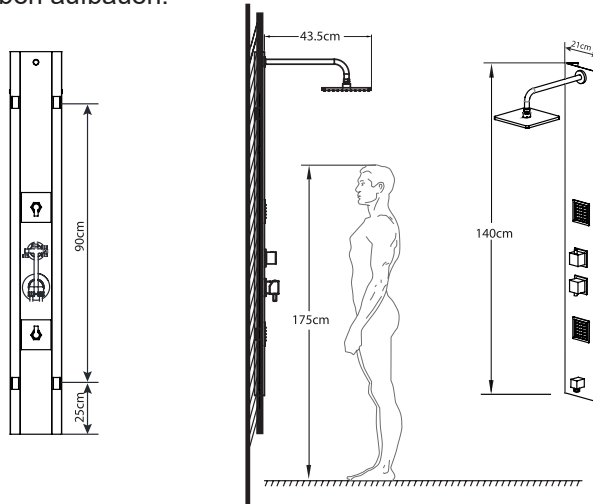

Achtung!

Die Größe kann verstellt werden, je nach den individuellen Anforderungen. Die Größe sind nur als Referenz gedacht.

Wählen Sie die gewünschte Duschfunktion, in dem Sie an dem Kontrollknopf drehen.

Volumen und Temperaturkontrolle

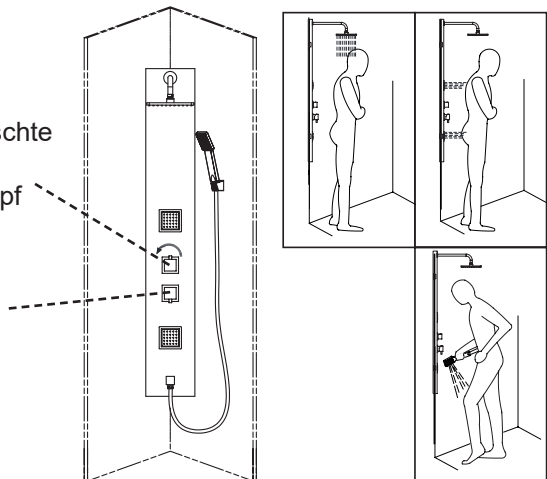

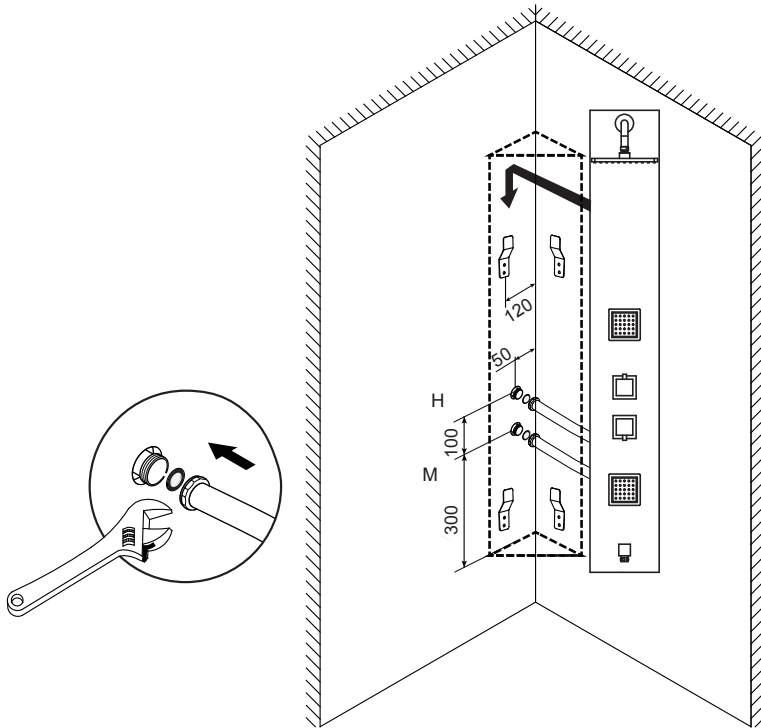

- DE **H:** Kaltes Wasser - 1/2" Verbindung
M: Heißes Wasser - 1/2" Verbindung

Bau und Installation eines Bodenablaufs ist obligatorisch!

Die angegebenen Maße sind nur Richtwerte und können aufgrund der Herstellungstechnologie des Produkts um +-1 Zentimeter variieren.

Die Bedienung unserer Duschpaneele und Armaturen ist auf einen idealen Wasserdruck zwischen 3,5-4,5 bar ausgelegt.

I. Fonction

1. Tête de Douche
2. Jets de corps
3. Déviateur
4. Mélangeur
5. Douche à main

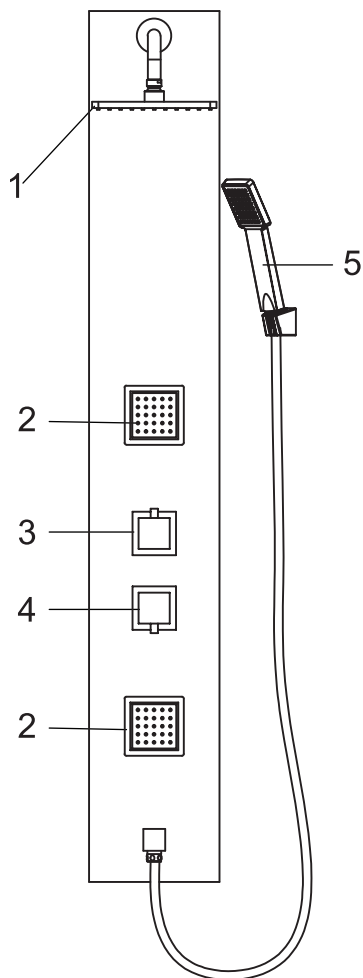

Liste des pièces

Veillez déballer et inspecter tous les emballages et composants avec soin, et assurez-vous qu'ils sont complets. Examinez les dommages dus au transport. Si certaines pièces sont endommagées ou manquantes, contactez immédiatement votre revendeur.

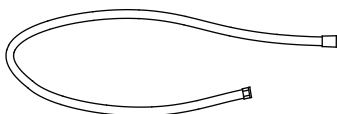
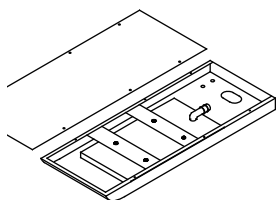
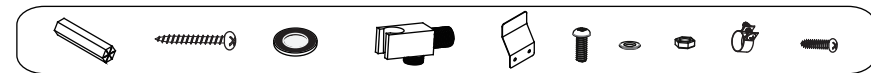

Pour l'installation, vous aurez besoin des outils suivants

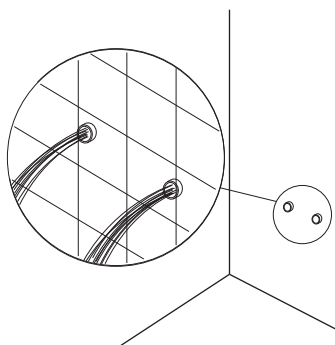
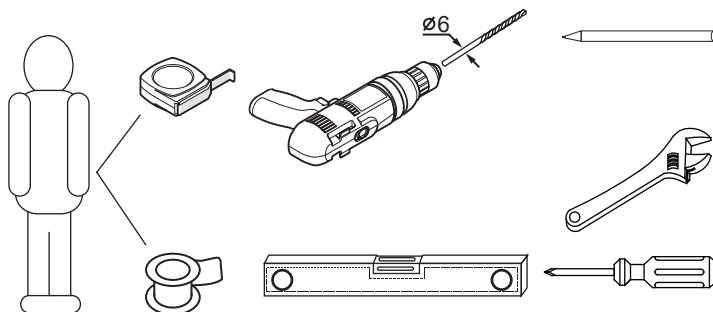

Remarque!

Avant l'assemblage, rincez les tuyaux de canalisation d'alimentation d'eau pour enlever les débris (faites couler de l'eau en ouvrant le robinet principal pendant environ 3 min), sinon les particules de saleté pourraient affecter le fonctionnement du panneau de douche!

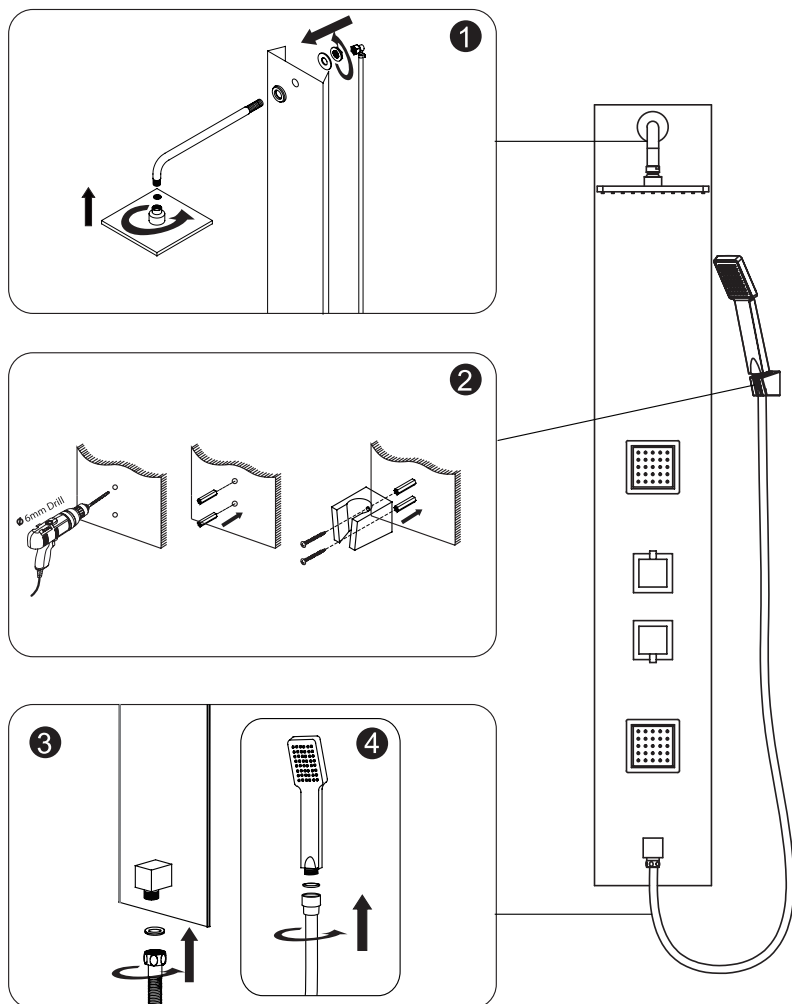

Montage mural

Remarque!

Avant de percer des trous pour la fixation de votre panneau de douche, assurez-vous qu'il n'y a pas de câbles ou de tuyauterie cachés dans le mur.

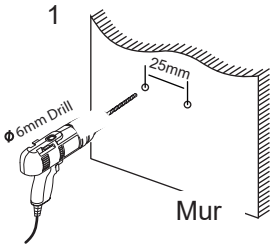

Percez les trous dans le mur

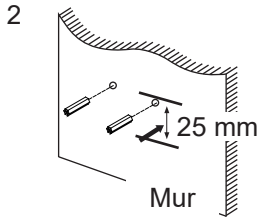

Insérez les chevilles dans les trous

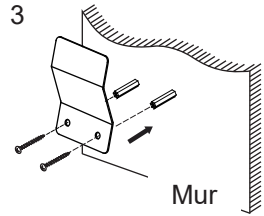

Serrez les vis au mur avec des supports de montage mural

Accrochez le panneau de douche sur le support de montage

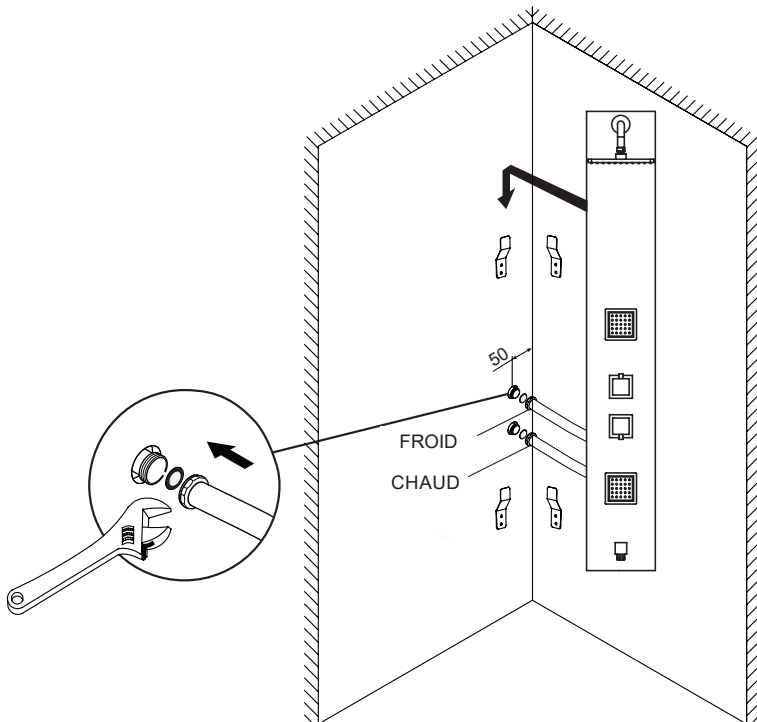

FR Dimensions

Choisissez un endroit approprié pour installer le panneau de douche, ajustez la position verticale du panneau de douche selon la taille de l'utilisateur et votre espace sanitaire. Généralement, installez les panneaux à la distance de 210cm du haut au sol, mais vous pouvez monter selon vos préférences.

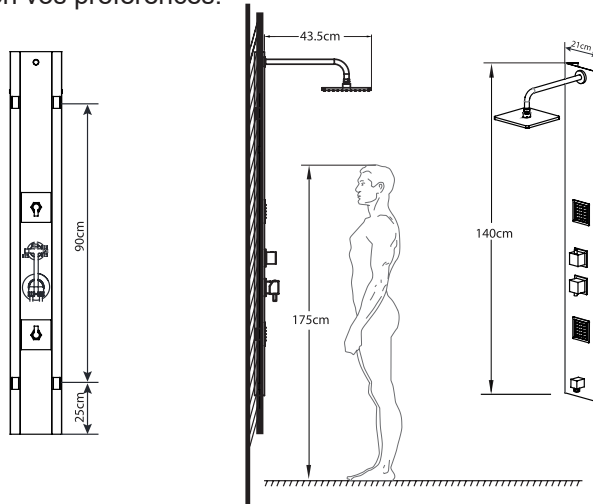

Remarque!

La hauteur peut être modifiée pour répondre à des exigences particulières. Les dimensions sont seulement pour référence.

Sélectionnez la fonction de la douche requise par rotation des boutons de commande.

Contrôle de température et de volume

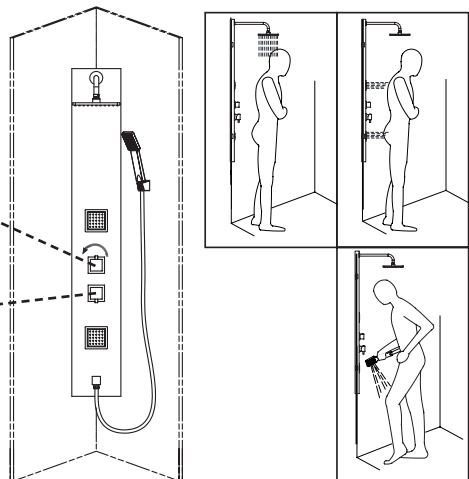

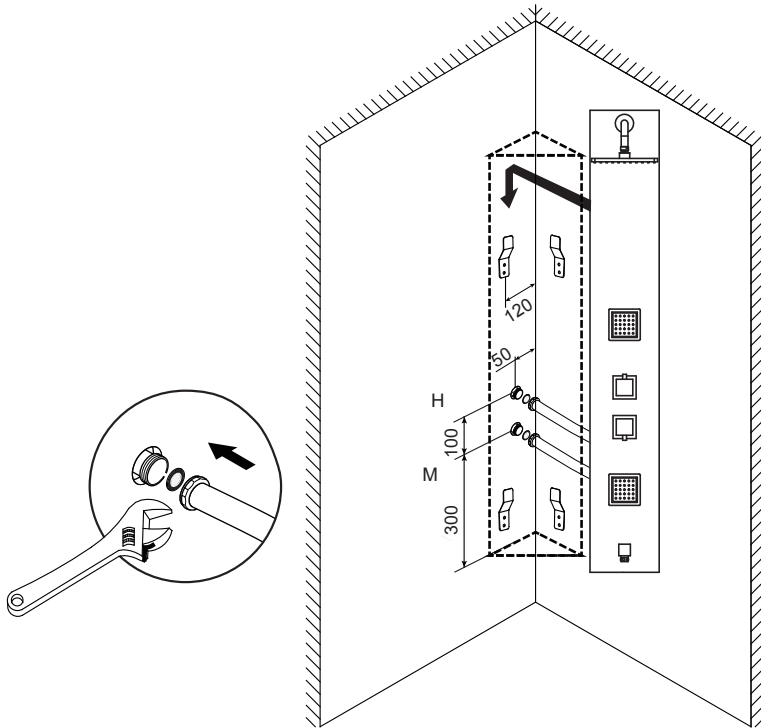

FR **H:** Eau froide - Lien ½ “
M: Eau chaude - Lien ½ “

La réalisation et l'installation d'un siphon de sol sont obligatoires !

Les dimensions sont données à titre indicatif et peuvent varier de +/-1 centimètre en fonction de la technologie de fabrication du produit.

Le principe de fonctionnement de nos colonnes de douche et de notre robinetterie est conçu pour une pression d'eau idéale entre 3,5 et 4,5 bars.

I. Működés

1. Zuhanypanel fej
2. Testvízsugarak
3. Áramláskapcsoló
4. Keverő
5. Kézizuhany

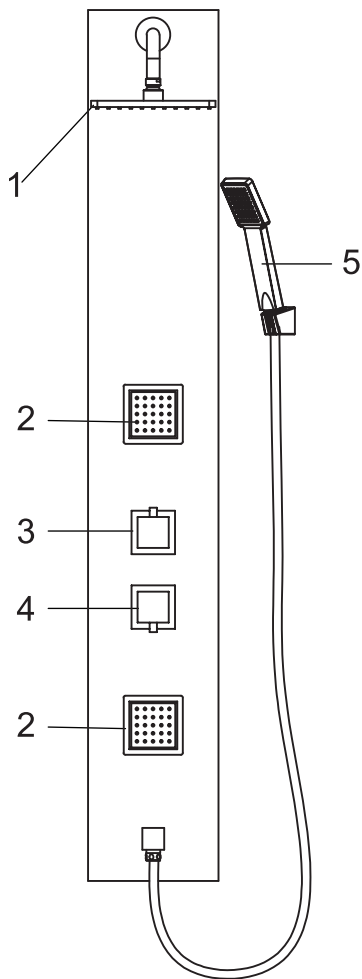

Alkatrészlista

Kérem, csomagoljon ki és gondosan vizsgáljon meg minden egységet és komponenst, és ellenőrizze, hogy nem-e hiányzik valami! Ellenőrizze a szállítás során fellépő sérüléseket! Ha bizonyos alkatrészek sérültek vagy hiányoznak, azonnal értesítse az eladót!

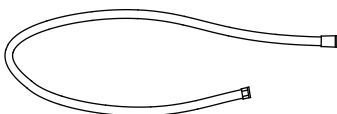
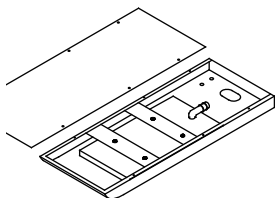
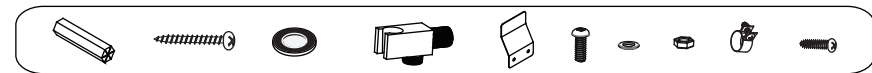

A szereléshez az alábbi eszközökre lehet szüksége

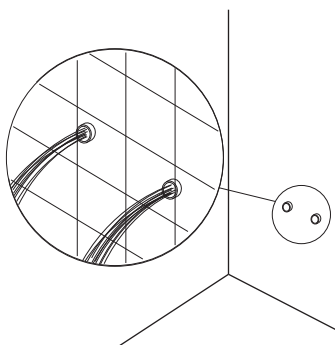
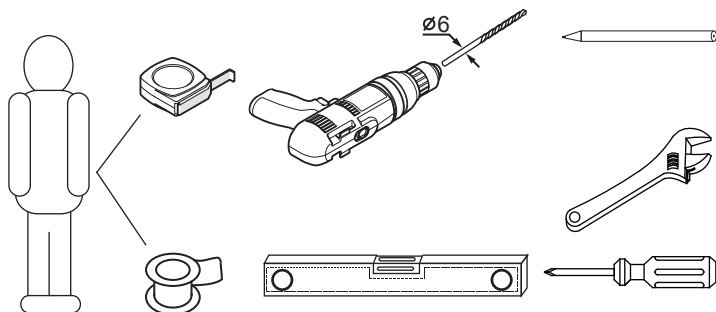

Megjegyzés!

Az összeszerelés előtt a vízvezetékcsövet alaposan öblítse át, hogy eltávolítsa a szennyező részecskéket! (a fő csapot kinyitva folyassa a vizet 3 percig), különben a szennyező részecskék befolyásolhatják a zuhanypanel működését!

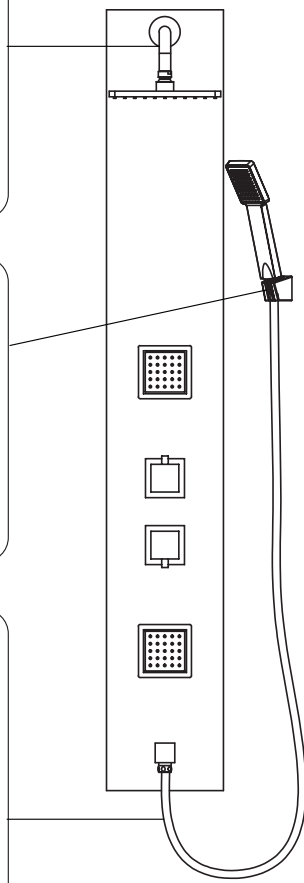
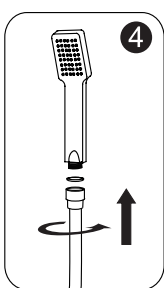
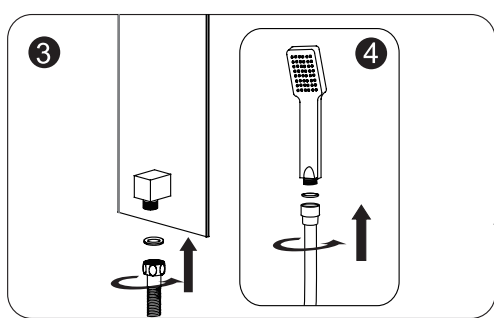
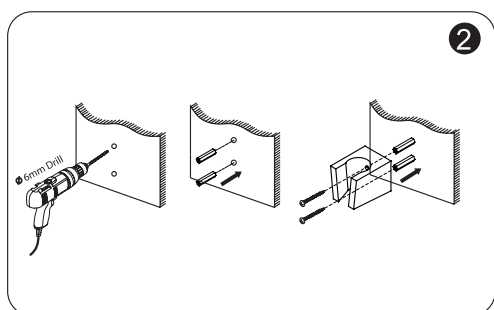
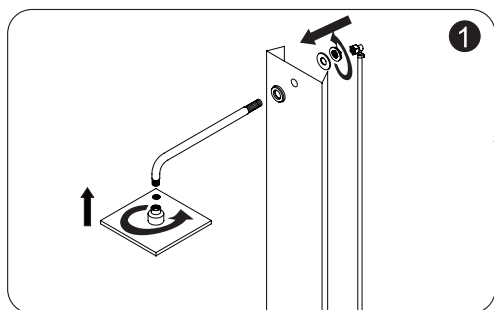

Falra-szerelés

Megjegyzés!

Mielőtt lyukakat fúrna a zuhanypanel rögzítéséhez, győződjön meg arról, hogy nincsenek rejtett vezetékek vagy csövek a fal belsejében

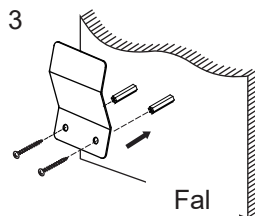
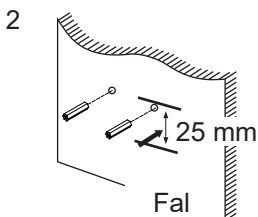
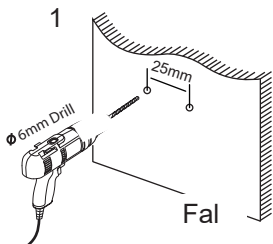

Fúrjon lyukakat a falba!

Illessze be a tipliket a lyukakba!

A csavarokat fali rögzítő lemez segítségével rögzítse a falhoz!

Fügessze fel a zuhanypanelt a fali rögzítő lemezre!

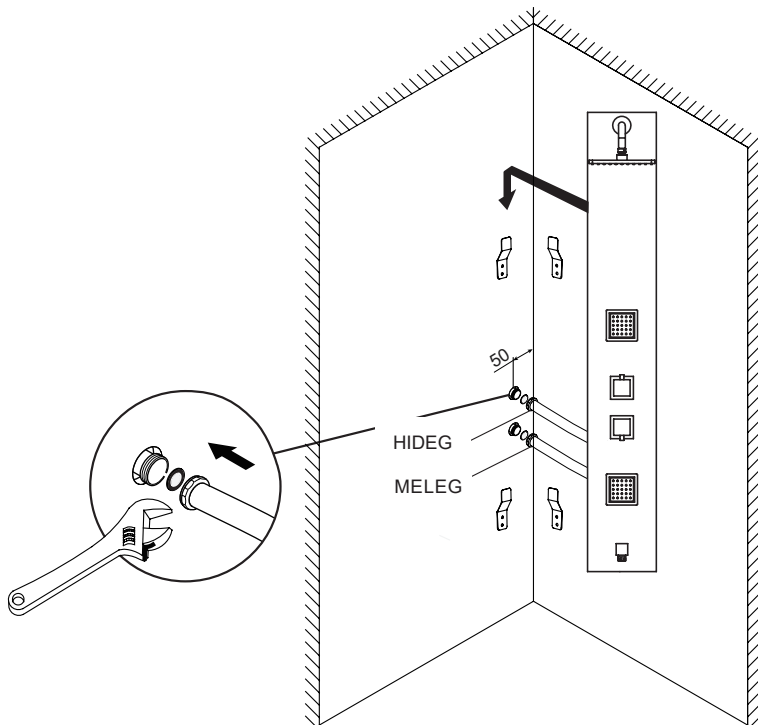

HU Méretek

Válasszon ki egy megfelelő helyet a zuhanypanel felszereléséhez és igazítsa a zuhanypanel függőleges pozícióját a felhasználó magasságához és a fürdőszobához! Tipikusan a padlótól számítva 210 cm magasságban szerelje fel a zuhanypanelt, de választhat egy másik magasságot is!

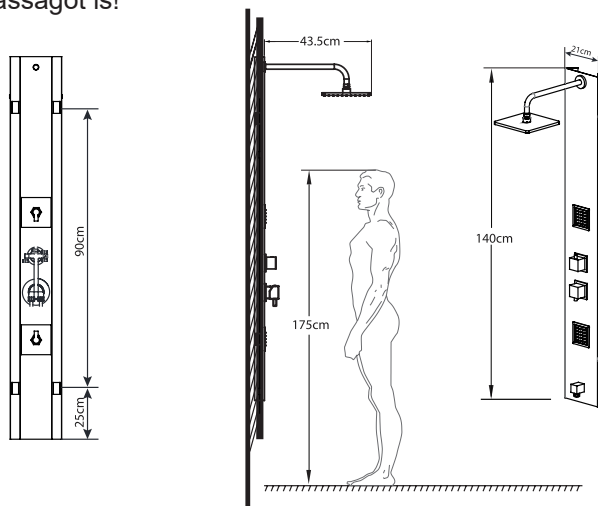

Megjegyzés!

A magasság módosítható az egyéni igényeknek megfelelően.
A méretek csak viszonyítási alapként szolgálnak.

Válassza ki a kívánt zuhanyfunkciót a szabályzó gomb elfordításával

Mennyiség és hőmérséklet szabályozás

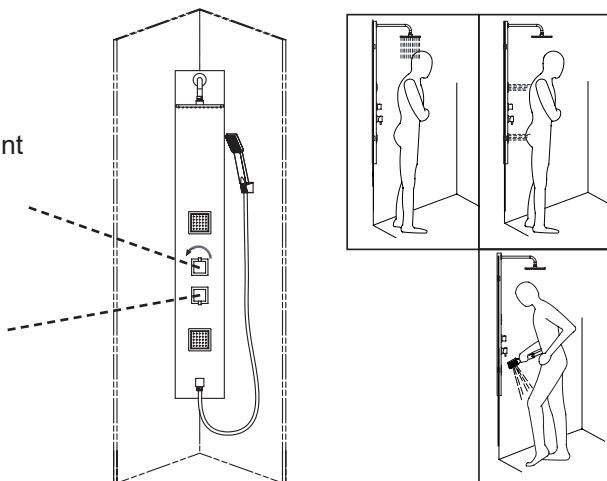

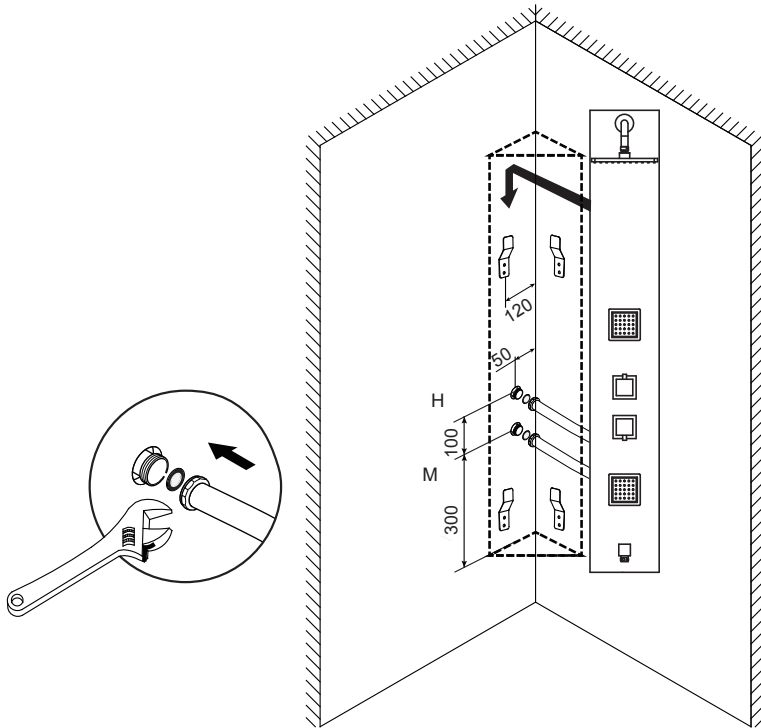

HU

H: Hidegvíz - 1/2"-os kiállás

M: Melegvíz - 1/2"-os kiállás

Padlóösszefolyó kiépítése kötelező!

A megadott méretek tájékoztató jellegűek, a termék gyártási technológiájából adódóan eltérőek lehetnek. +-1 cm.

Zuhanypaneljeink és csapterelepeink működése az ideális 3,5-4,5 bar közötti víznyomásra van tervezve.

I. Funcționare

1. Cap panou de duș
2. Jeturi apă pentru corp
3. Comutator de flux
4. Baterie amestec
5. Pară de duș

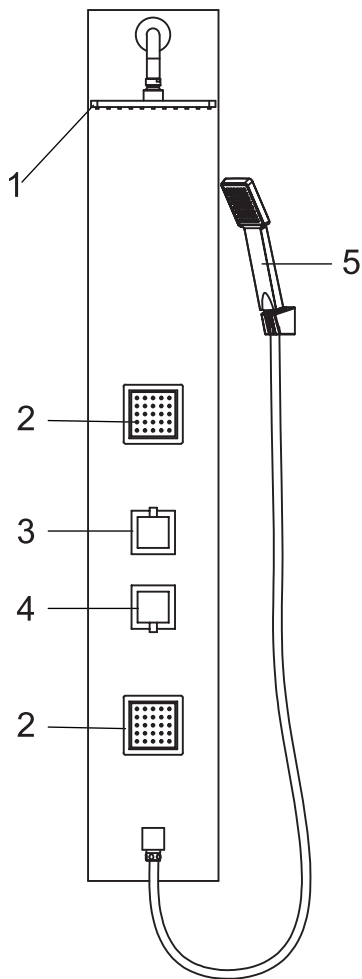

Listă de piese

Despachetați și verificați cu grijă toate unitățile și componentele și verificați dacă nu lipsește vreuna! Verificați pentru deteriorări intervenite în urma transportului! Dacă anumite piese lipsesc sau sunt deteriorate, informați imediat vânzătorul!

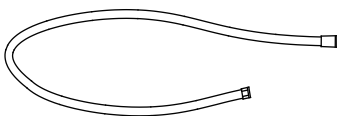
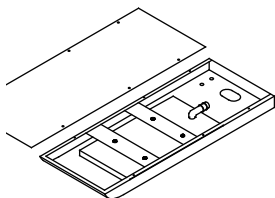
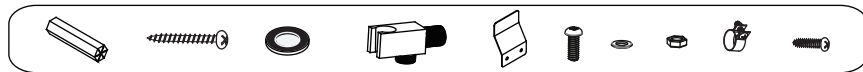

Pentru montare aveți nevoie de următoarele scule

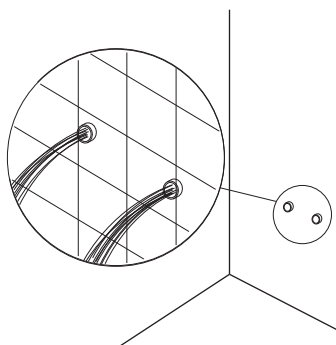
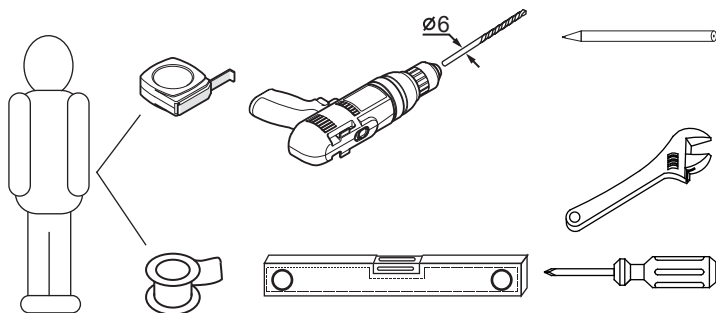

Notă!

Clățiți bine țevile de apă înainte de asamblare pentru a îndepărta murdăria! (ținând deschis robinetul principal timp de 3 minute), în caz contrar murdăria poate afecta funcționarea panoului de duș!

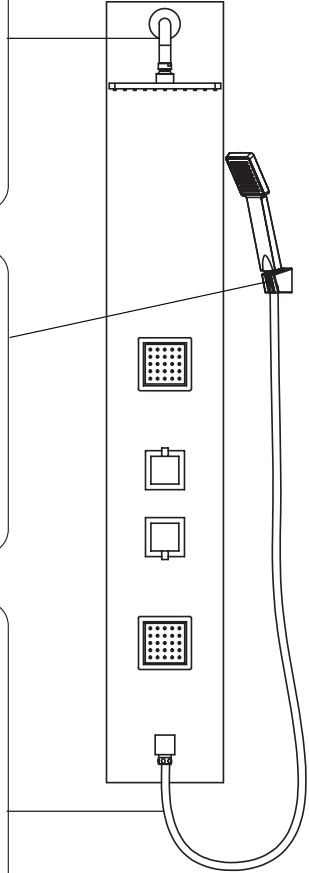
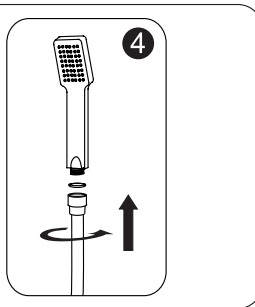
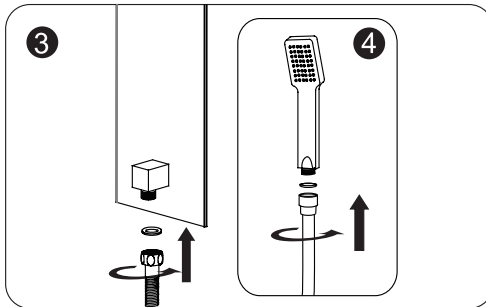
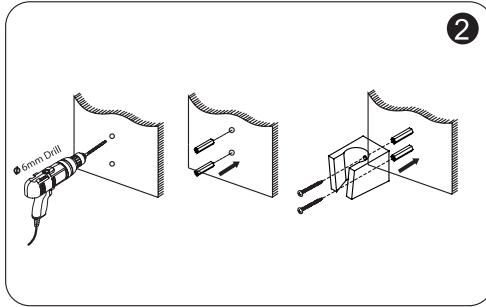
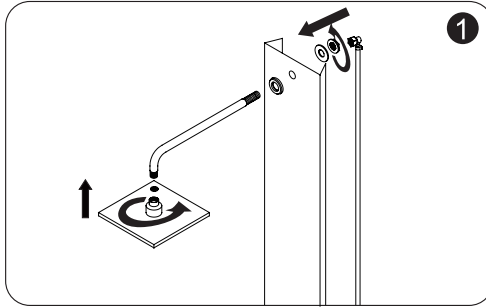

Montarea pe perete

Notă!

Înainte de a realiza găurile pentru fixarea panoului de duș, asigurați-vă că în perete nu există țevi sau cabluri ascunse

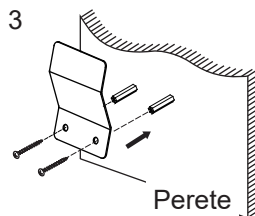
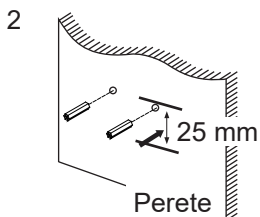
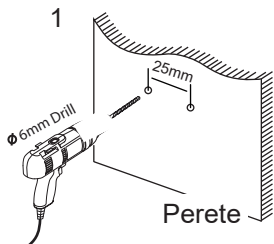

Găuriți peretele!

Introduceți diblurile în perete!

Prindeți șuruburile de perete cu ajutorul plăcii de fixare!

Montați panoul de duș pe placa de fixare!

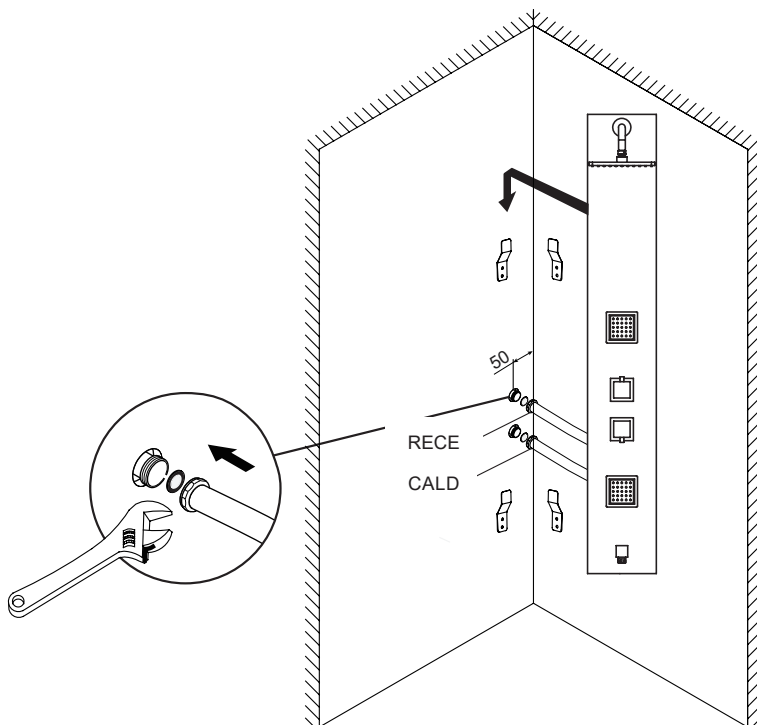

RO Dimensiuni

Alegeți un loc corespunzător pentru montarea panoului de duș și reglați poziția verticală a panoului de duș la înălțimea utilizatorului și baie! Panoul de duș se montează, de regulă la înălțimea de 210 cm, dar poate fi montat și la altă înălțime!

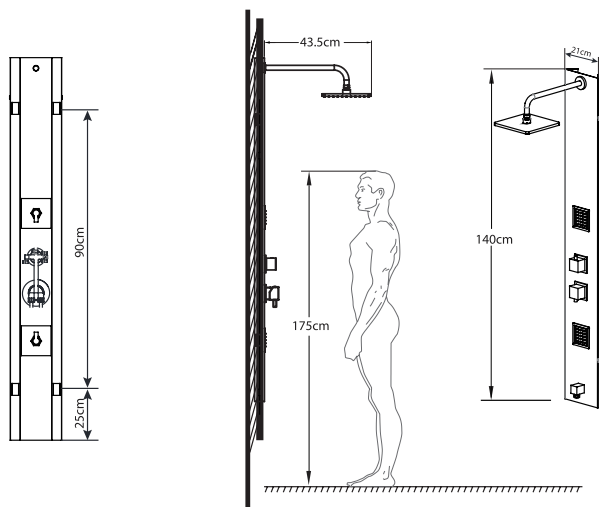

Notă!

Înălțimea se poate modifica în funcție de necesitățile individuale. Mărimile sunt date numai cu titlu comparativ.

Alegeți funcția de duș dorită rotind butonul

Reglarea cantității și temperaturii

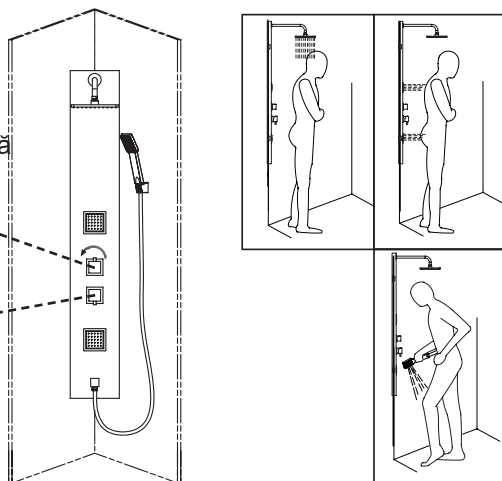

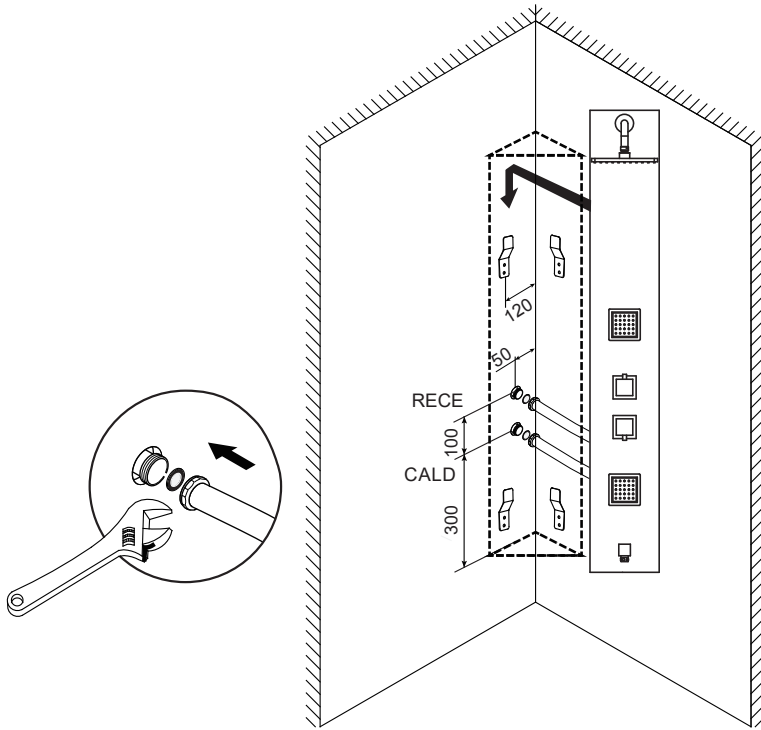

RO

H: Apă rece - racord 1/2"

M: Apă caldă - racord 1/2"

Este obligatorie montarea unui sifon de pardoseală!

Dimensiunile date sunt informative, produsul poate diferi din cauza tehnologiei de fabricare. +-1 cm.

Funcționarea ansamblurilor și a robinetelor noastre de duș este adaptată pentru o presiune ideală a apei de 3,5-4,5 bari.

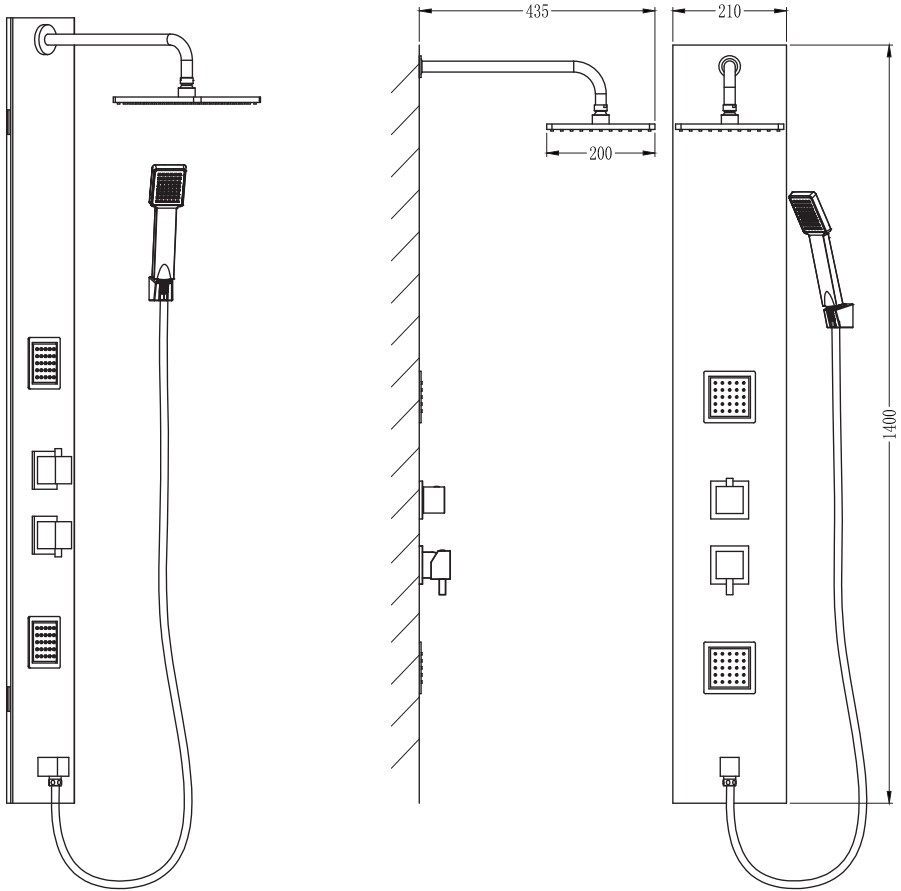

Wellis®

CE