

PL Instrukcja montażu

GB Assembly instruction

D Montageanleitung

SK Návod na inštaláciu

CZ Pokyny k instalaci

RUS Инструкция по установке

UA Інструкція по установці

H Szerelési útmutató

RO Instrucțiuni de montaj

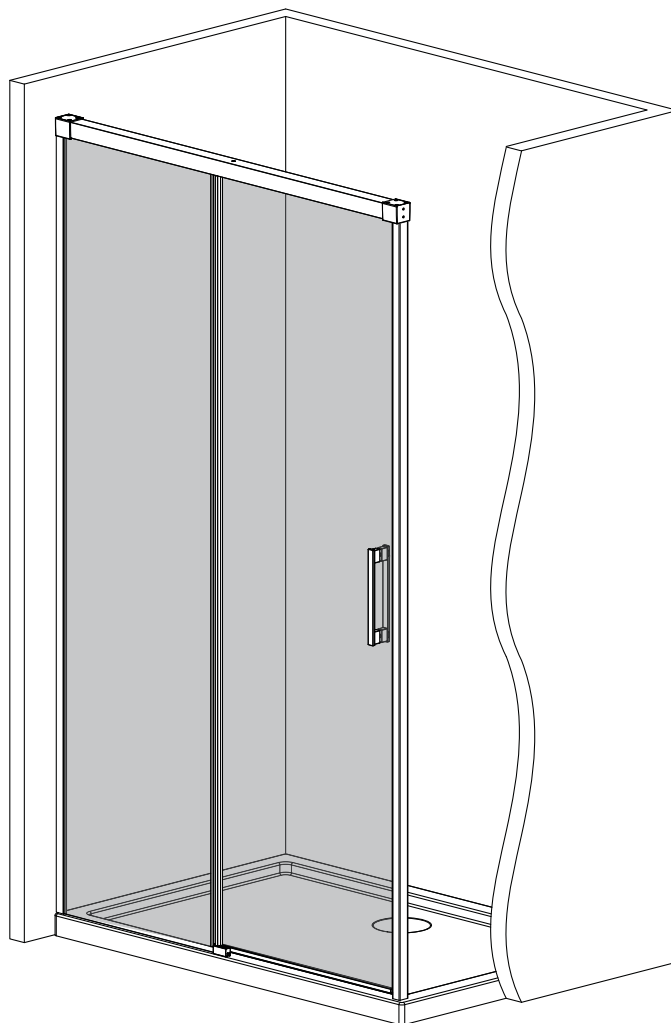

Idea DWJ

PL Instrukcja pokazuje montaż kabiny w wariacie lewym

GB Assembling instruction shows installation of left-side version

D Die Montageanleitung stellt die linke Variante der Dusche dar

SK Návod na inštaláciu sa vzťahuje na ľavé prevedenie

CZ Návod zobrazuje instalaci sprchového koutu vlevo

RUS В инструкции указан монтаж левого варианта кабины

UA В інструкції вказаний монтаж лівого варіанту kabini

H A szerelési útmutató balos verzióra vonatkozik

RO Instrucțiunile de montaj se refera la instalarea cu deschidere pe stanga

Beépítési tudnivalók

2+1ÉV**GARANCIA**

Beépítéshez javasoljuk megnövelt (2+1 év) garanciával a saját márkaszervizünket, az ország egész területén.

Beszereles megrendelés: szerviz@metahungary.hu | radaway.hu

A Radaway márkaszervizünk garantálja:

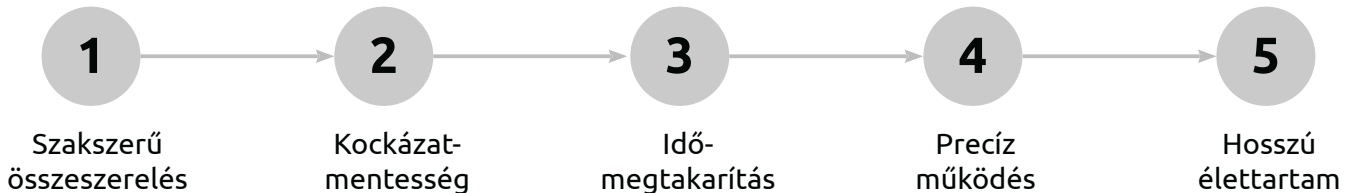

Mielőtt saját kezűleg kezd hozzá a beépítéshez, ezt mindenképp tudnia kell!

1. Beépítés előtt kérjük, ellenőrizze a termék minőségét, hogy nincs-e a terméknek hibája, nem sérült-e a szállítás során.
2. Feltétlenül ellenőrizze le, hogy az áru megjelenése, méretei és színe (cikkszám) megfelel-e az Ön megrendelésének.
3. Beépítés után a gyártó csak a gyártási és az anyaghibákra ismeri el a garanciát. A már beszerelt terméken észlelt hibákért nem vállalunk felelősséget. Annak plusz költségeit nem áll módunkban átvállalni.
4. A terméket kizárólag rendeltetésszerűen lehet használni, ellenkező esetben a garanciális jog elvész.
5. A beszerelt terméket a szilikonos tömítés után 24 órával lehet csak használni.
6. A szerkezeti változtatás jogát fenntartjuk.
7. Ajánlás: A termék beszereléséhez két ember szükséges.

A zuhanykabinra és zuhanytálcára alap esetben 2 év jótállást vállalunk.

A jótállási idő a számla kiállításának napjával indul. Garanciális igényeit közvetlenül nálunk, márkaszervizünkhöz fordulva is érvényesítheti.



A garanciális igény érvényesíthetőségének egyik feltétele, hogy a termék szakszerűen, jelen szerelési útmutató szerint kerüljön üzembe helyezésre, beépítésre. A nem szakszerűen beépített vagy rögzített termékre a garancia nem terjed ki, annak javítása, ill. cseréje során a bontási és helyreállítási költségek, valamint a kiszállás díja a vevőt terheli. Üvegtörés esetén a garanciális feltételek nem érvényesíthetőek.

A Radaway márkaszerviz igénybevétele esetén a megnövekedett jótállási idő 2+1 év!

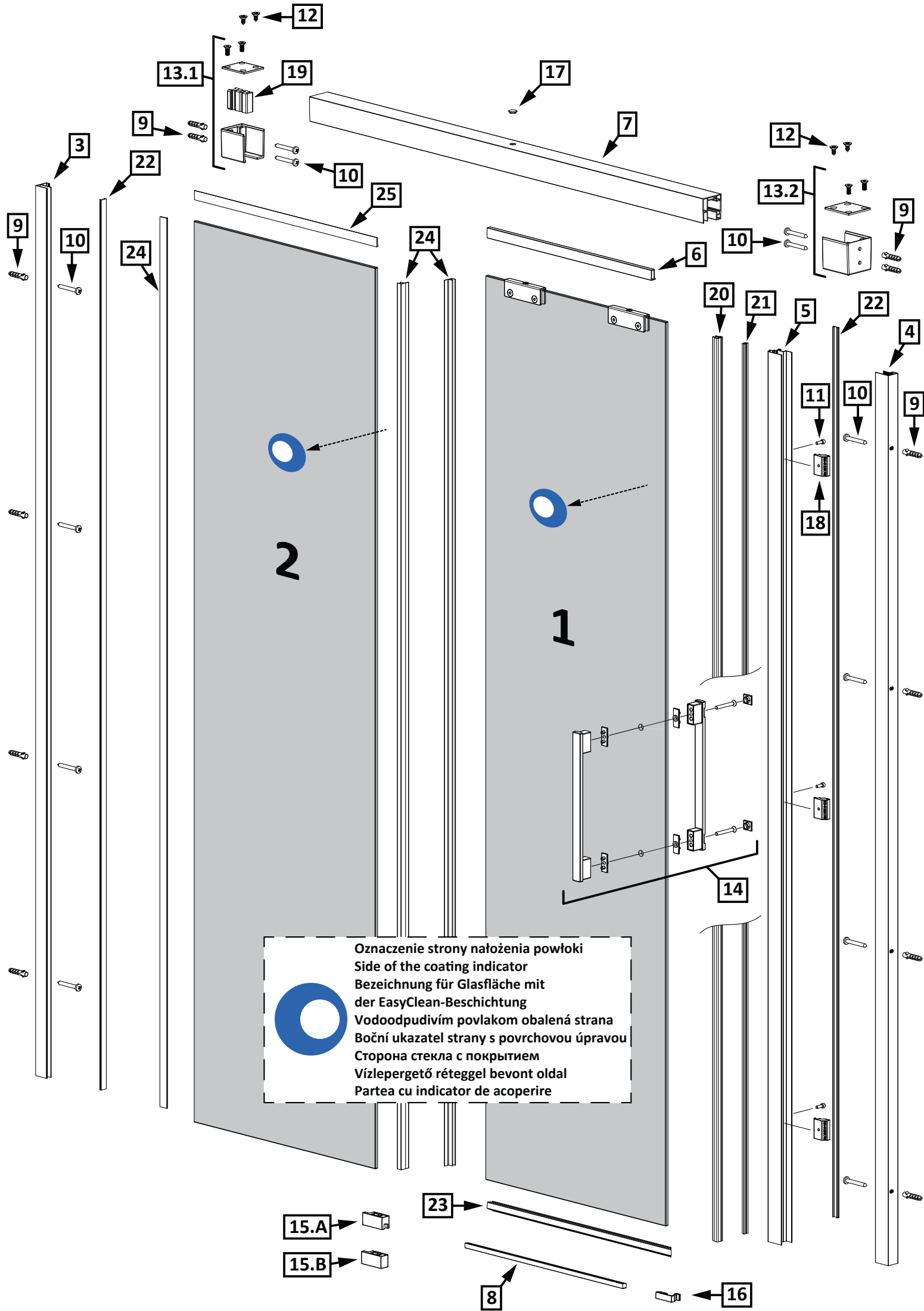









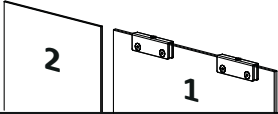
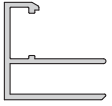
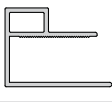
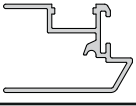

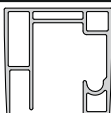
A jótállás részletes feltételeit a jótállási jegy tartalmazza.





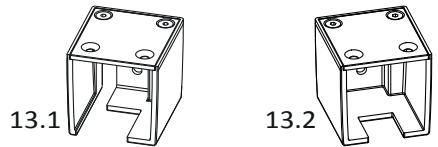

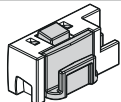
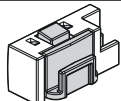
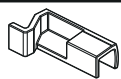



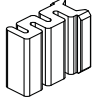

 Oznaczenie strony nalożenia powłoki
 Side of the coating indicator
 Bezeichnung für Glasfläche mit
 der EasyClean-Beschichtung
 Vodoodpudivim povlakom obalená strana
 Voční ukazatel strany s povrchovou úpravou
 Сторона стекла с покрытием
 Vízlepergető réteggel bevont oldal
 Partea cu indicator de acoperire

- 15.A 
- 15.B 

8  16 

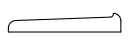
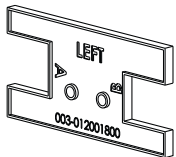
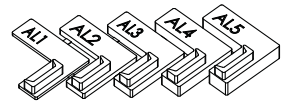
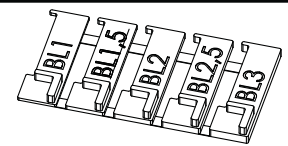
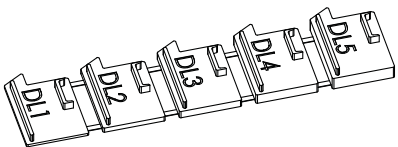
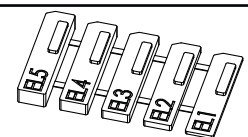
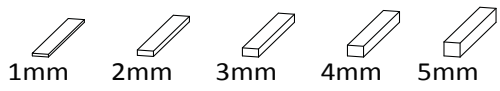
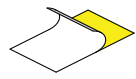
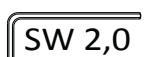
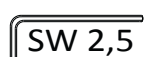
Nr Nr No. číslo počet № Sorszám Numar	Oznaczenie Mark Bezeichnung Označenje Označení обозначение Jelölés Componenta	Sztuk Pcs. Stück Kus KS штук Db. Bucati
1. 2.		1 1
3.		1
4.		1
5.		1
6.		1
7.		1
8.		1
9.	 $\phi 8$ DIN 7981	12
10.	 5x40 DIN 7991	12
11.	 M4x12 DIN 912	3
12.	 ST4.2x9.5 DIN 7982	4
13.1 13.2		1 1
14.		1
15.A		1
15.B		1
16.		1
17.		1
18.		3

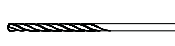
Montaż z listwą progową
 Installation with threshold profile
 Die Montage mit Schwalleiste
 Montovanie s prahovým profilom
 Instalace přechodové lišty
 Монтаж с профилем порога
 Szerelés küszöb profillal
 Instalarea cu profil prag

Nr Nr No. číslo počet № Sorszám Numar	Oznaczenie Mark Bezeichnung Označenje Označení обозначение Jelölés Componenta	Sztuk Pcs. Stück Kus KS штук Db. Bucati
19.		1
20.		1
21.		1
22.		2
23.		1
24.		2
25.	 L = 3000mm	1
26.		1
27.		1
28.		1
29.		1
30.		1
31.	 1mm 2mm 3mm 4mm 5mm	4
32.		4
33.1 33.2 33.3	 SW 2,0  SW 2,5  SW 3,0	1 1 1
34.	 ϕ 2,8	1

Montaż z listwą progową
Installation with threshold profile
Die Montage mit Schwalleiste
Montovanie s prahovým profilom
Instalace přechodové lišty
Монтаж с профилем порога
Szerelés küszöb profillal
Instalarea cu profil prag

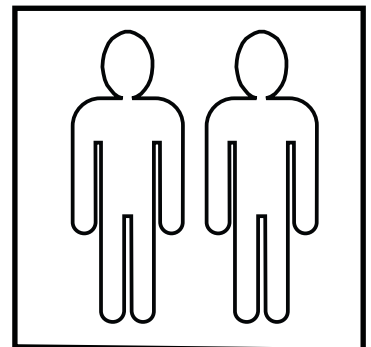
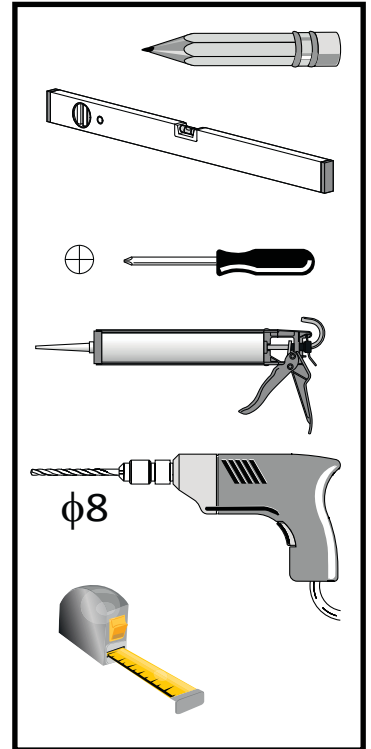

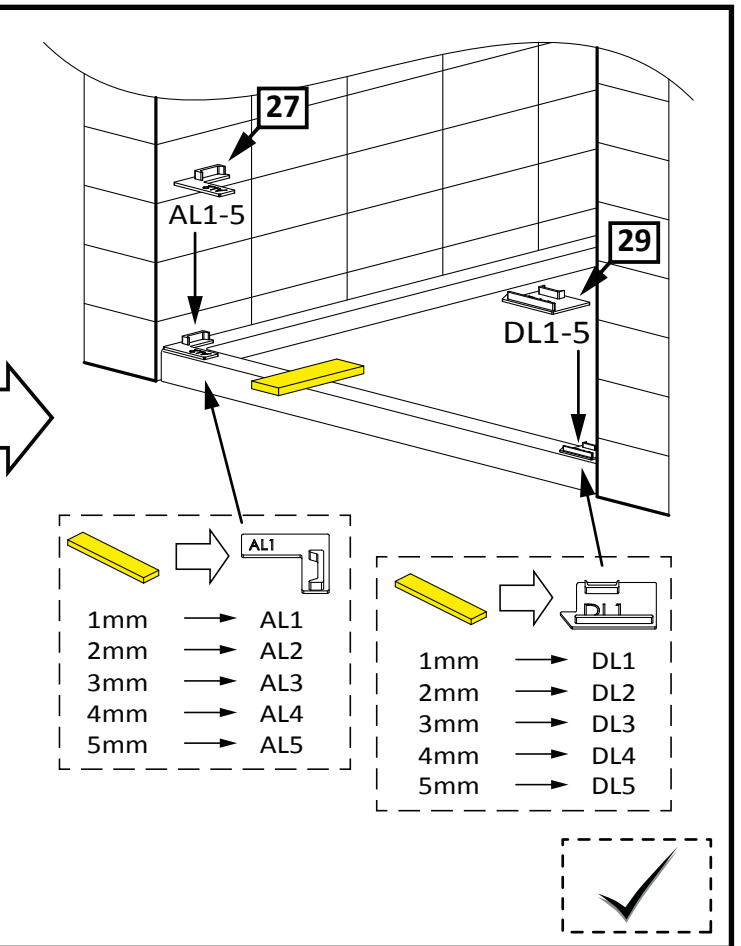
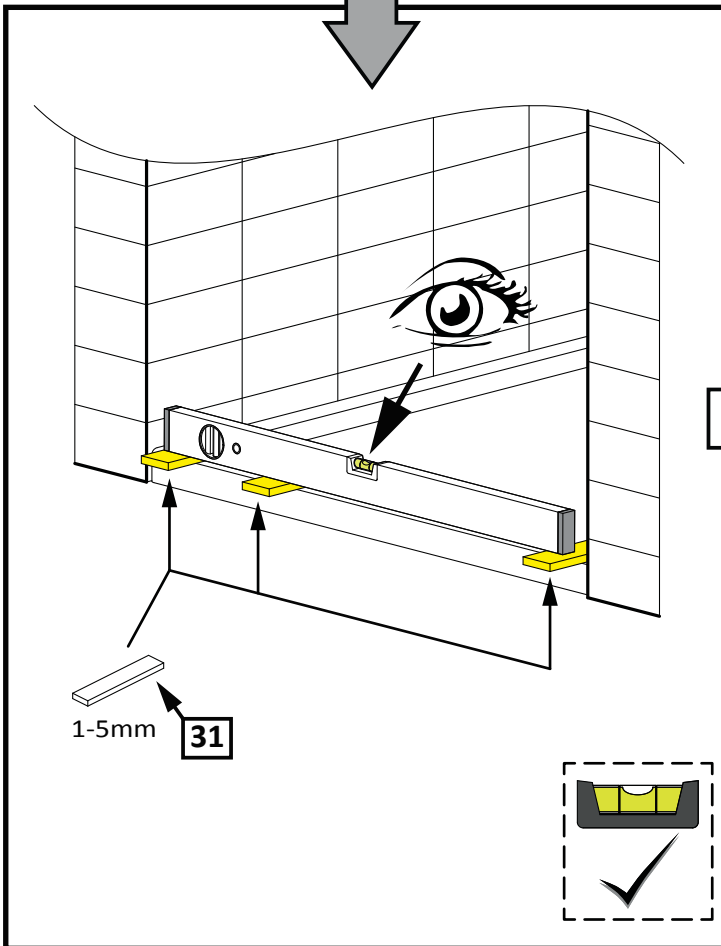
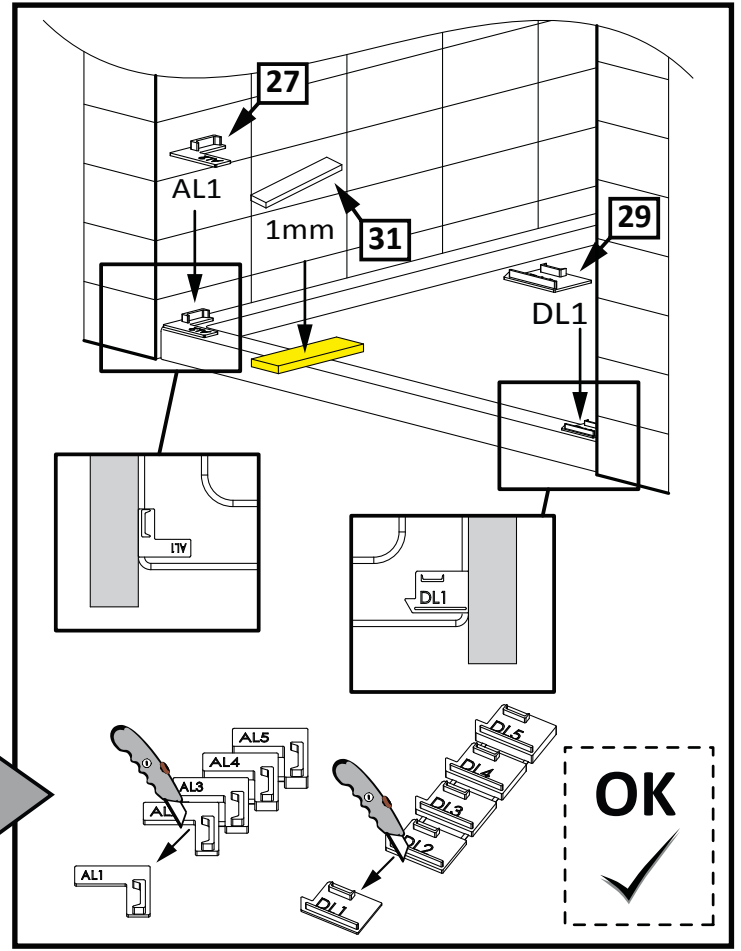
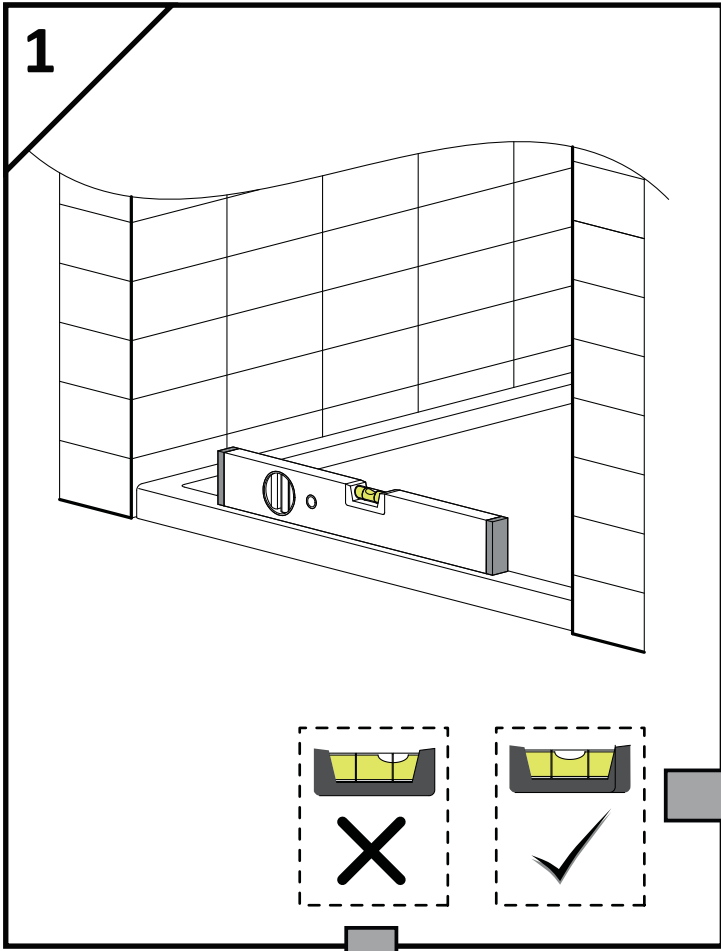

2

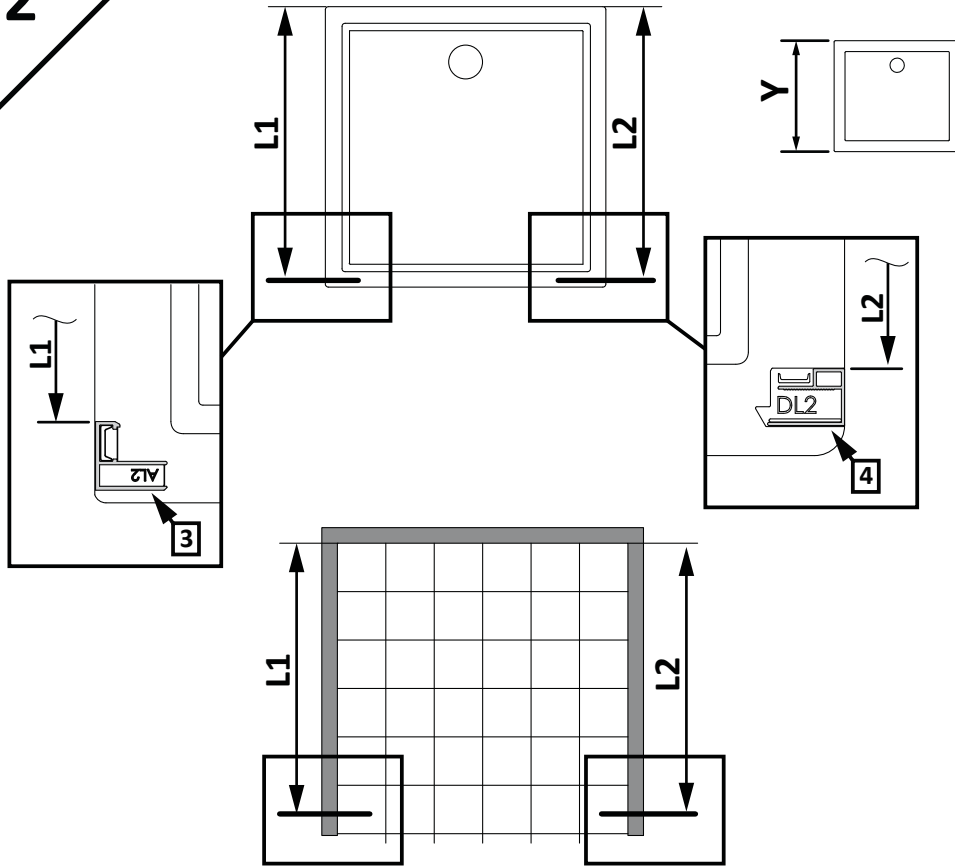

Y	800	900	1000	1100	1200
L1	766*	866*	966*	1066*	1166*
L2	763*	863*	963*	1063*	1163*

- PL** * Wymiary dotyczą montażu typowej kabiny montowanej na brodziku
- GB** * All dimensions refer to installation on shower tray
- D** * Die Masse betrifft standard Dusche, die auf der Duschwanne montiert ist
- SK** * Všetky miery platia pri osadení sprchovej vaničky
- CZ** * Montážní rozměry se vztahují k instalaci na sprchové vaničky
- RUS** * Размеры касаются монтажа стандартной кабины на поддоне
- H** * Az összes méret zuhanytálcára történő építés esetén érvényes
- RO** * Toate dimensiunile se referă la instalarea pe cădița de duș

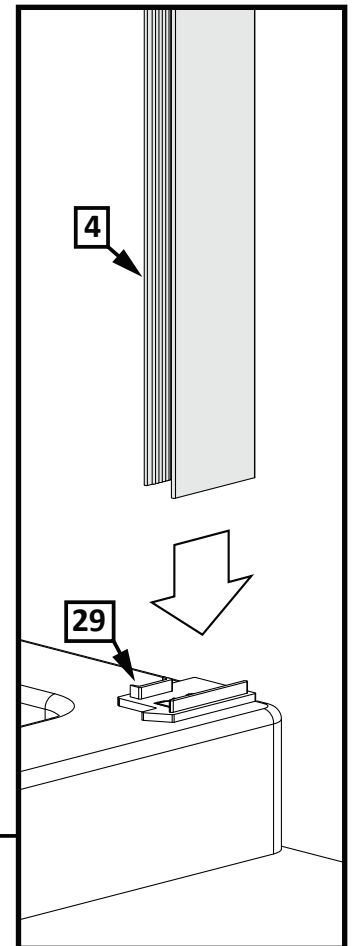
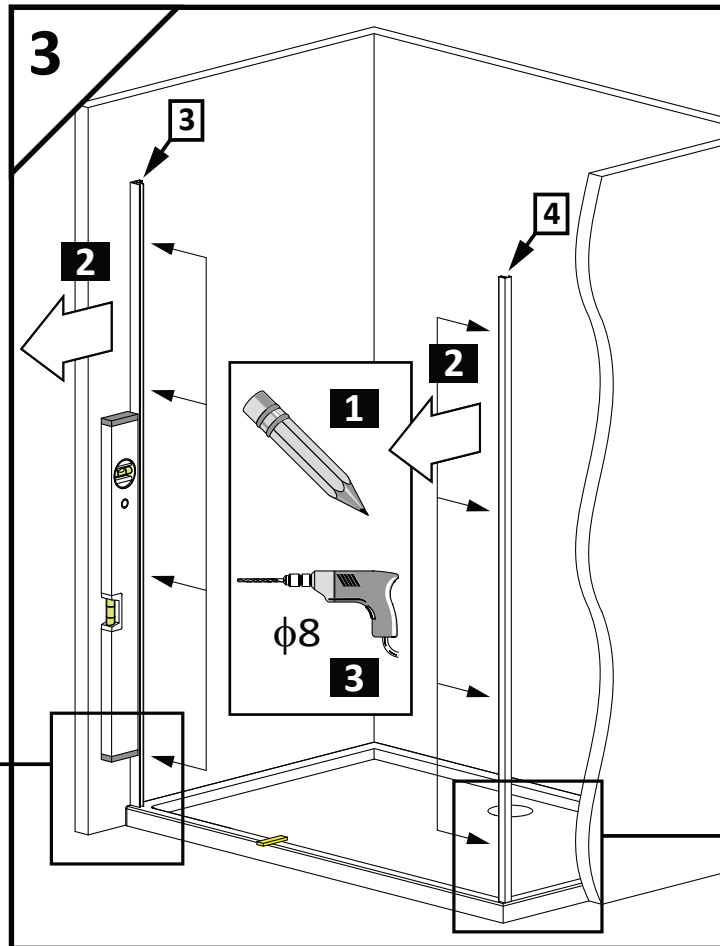
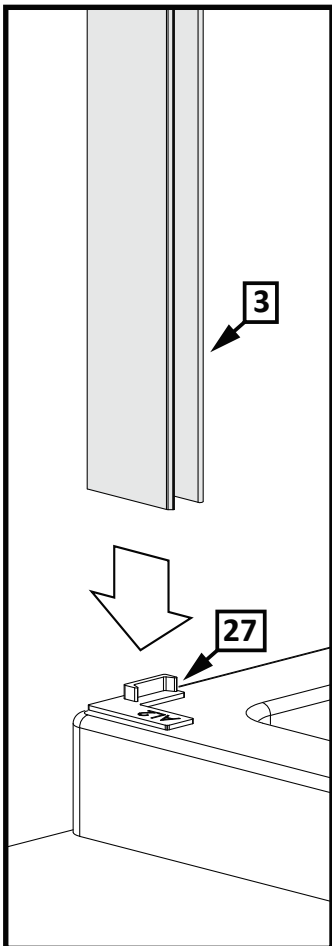

6

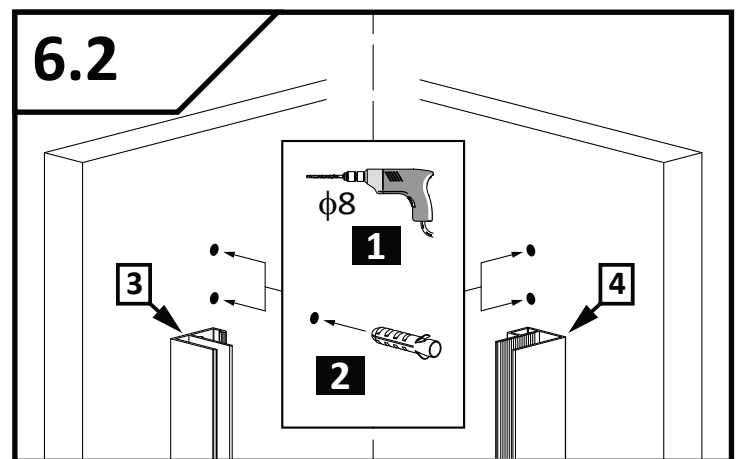
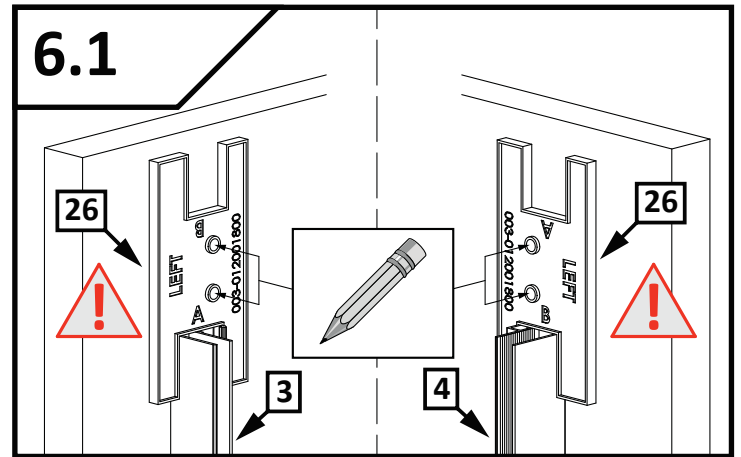
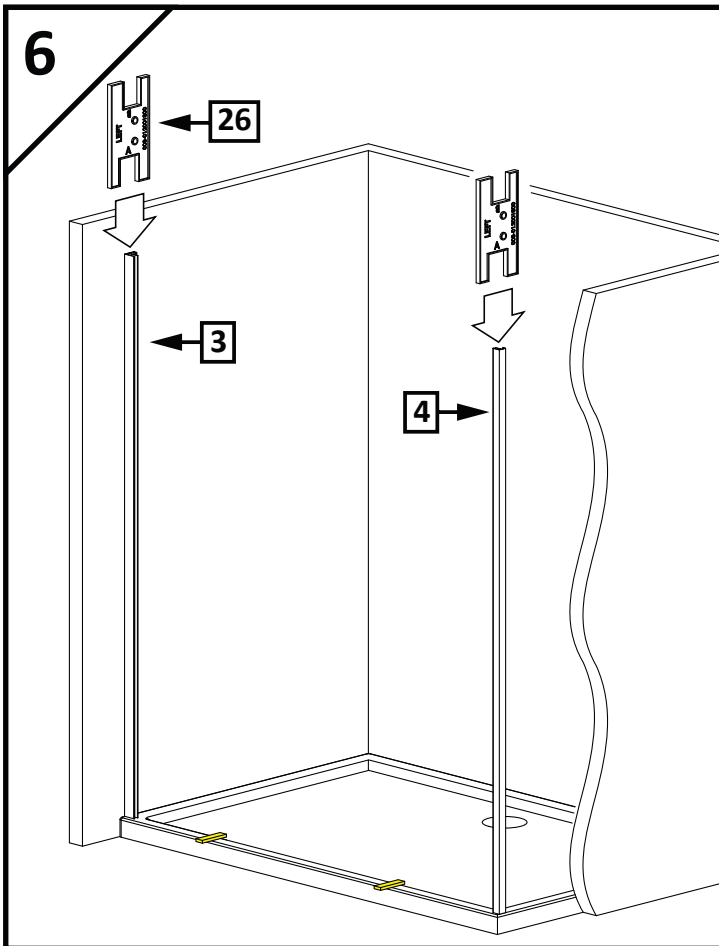
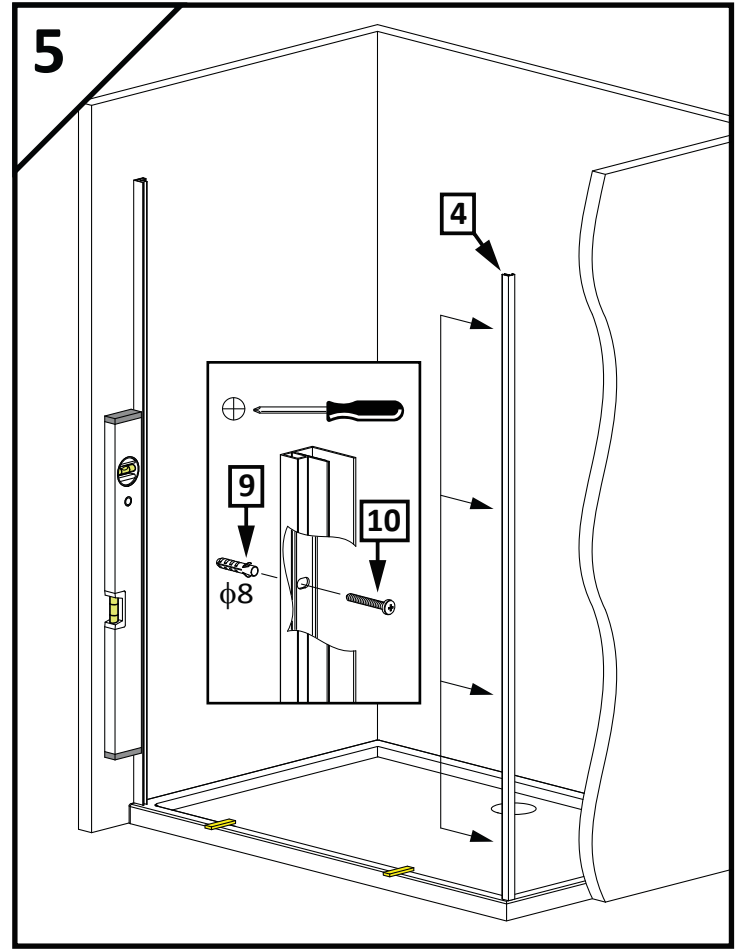
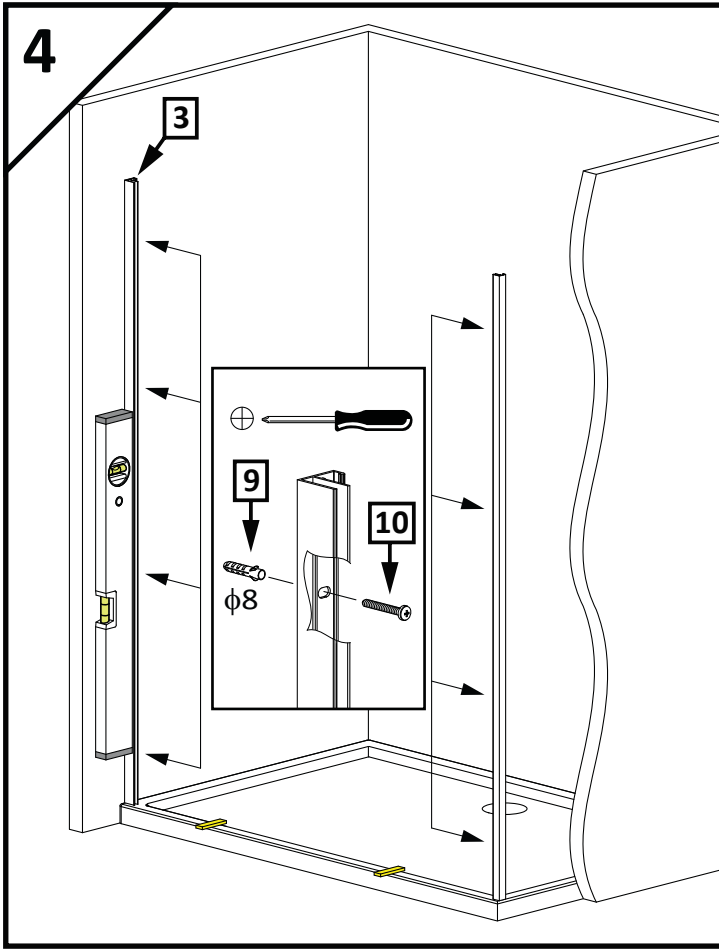

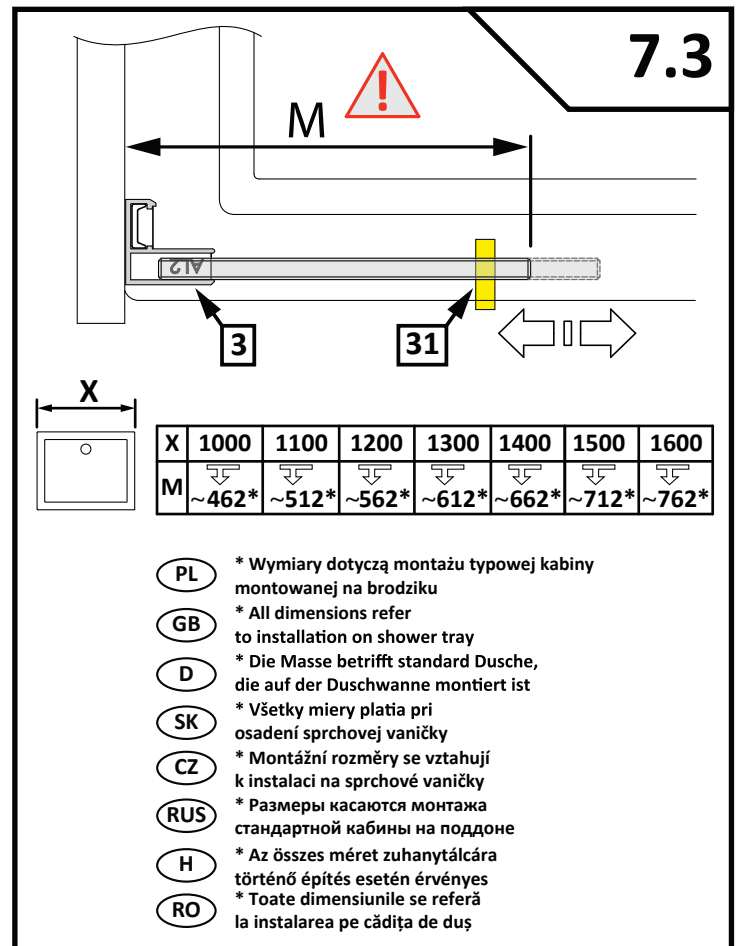
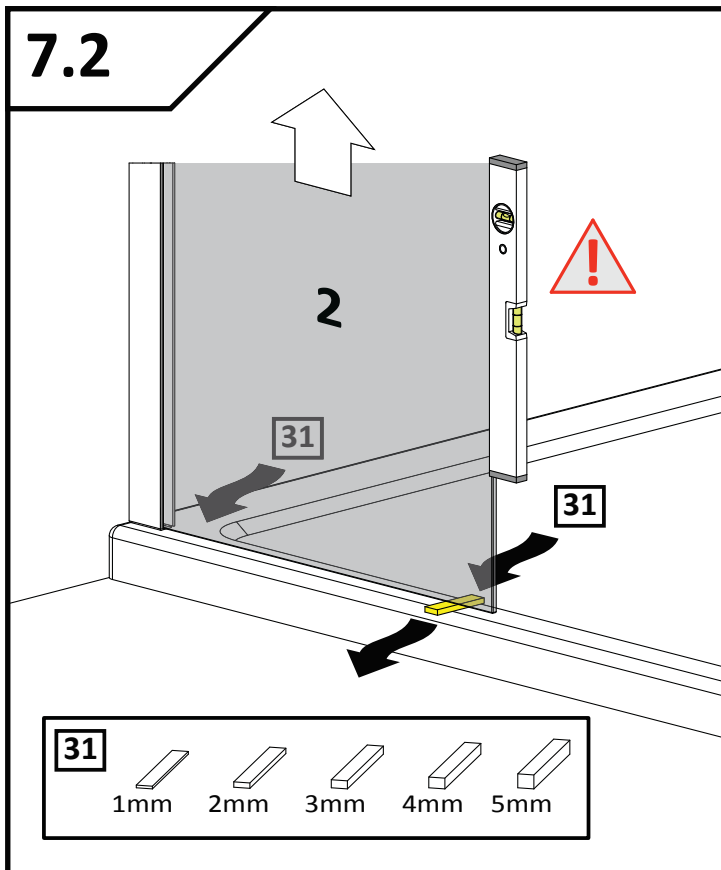
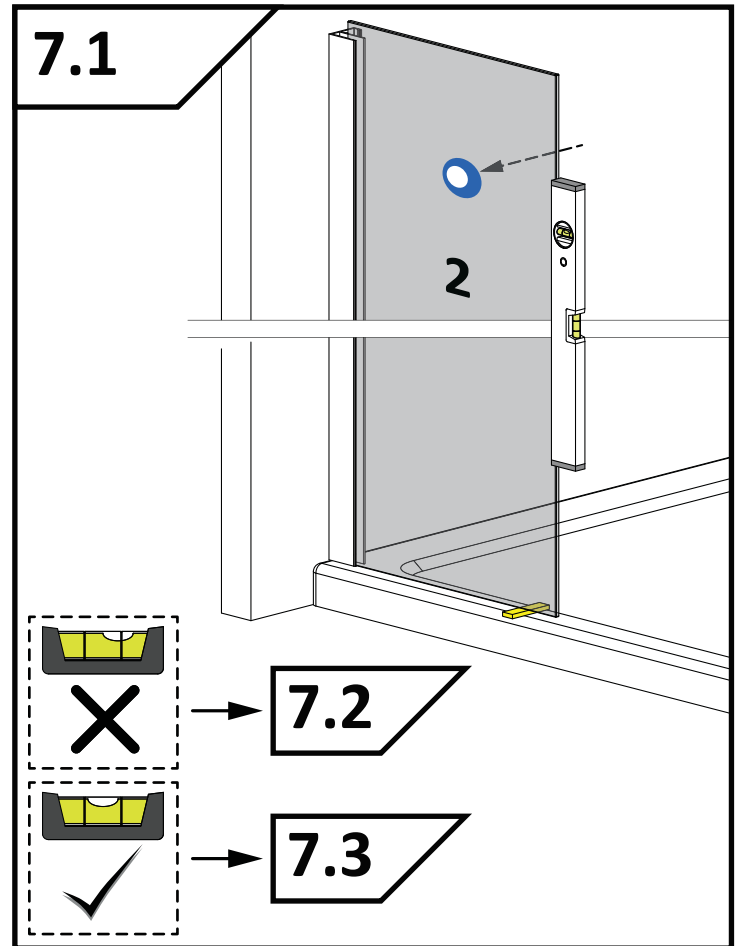
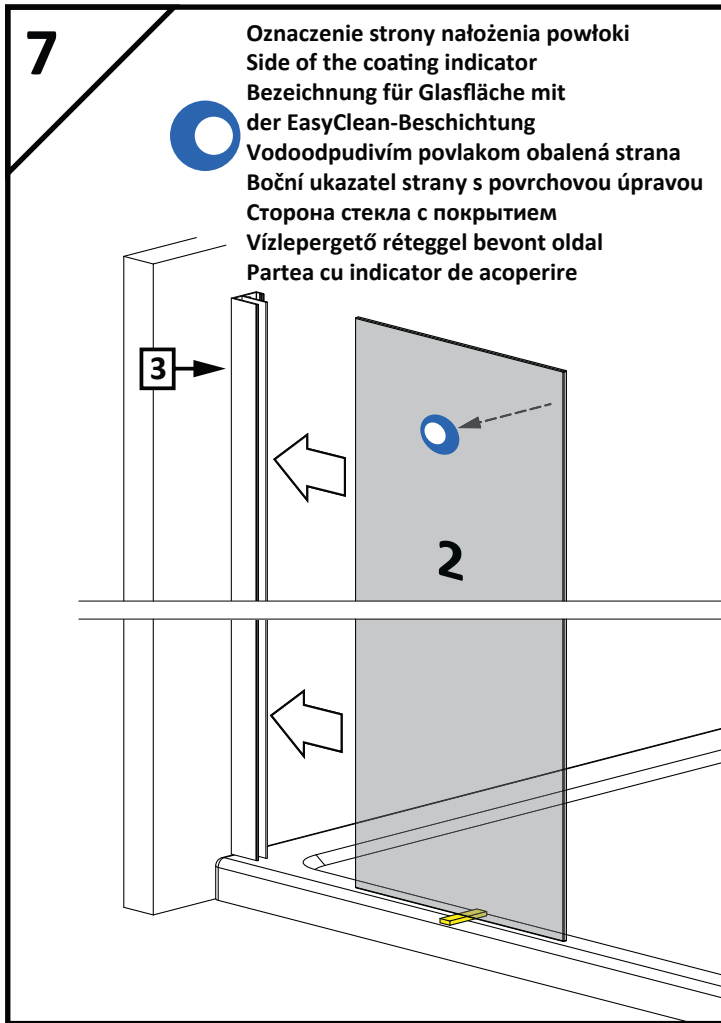

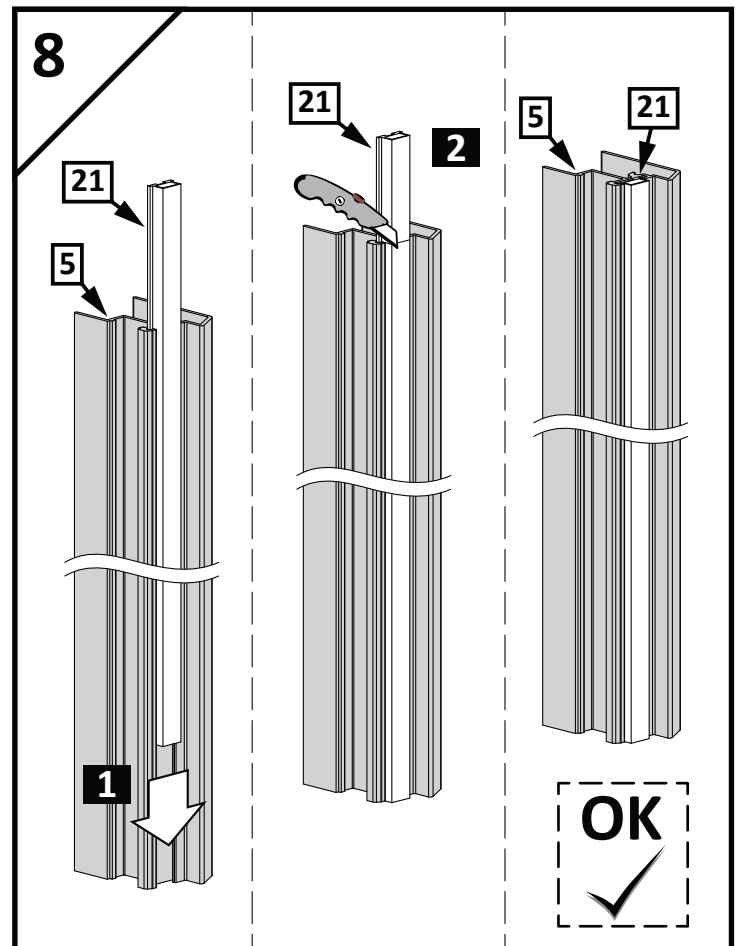
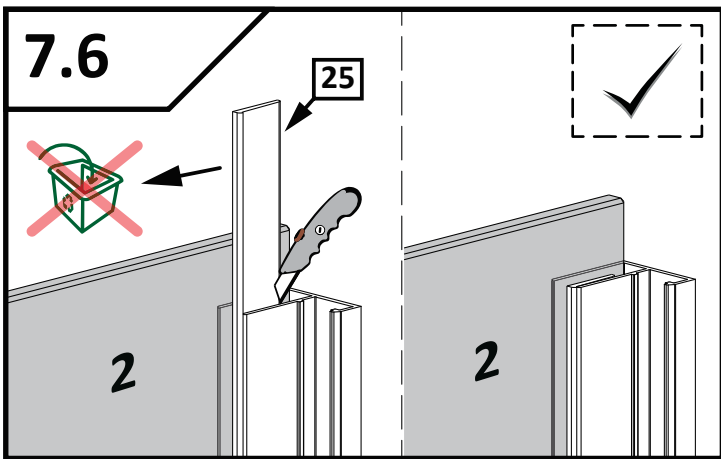
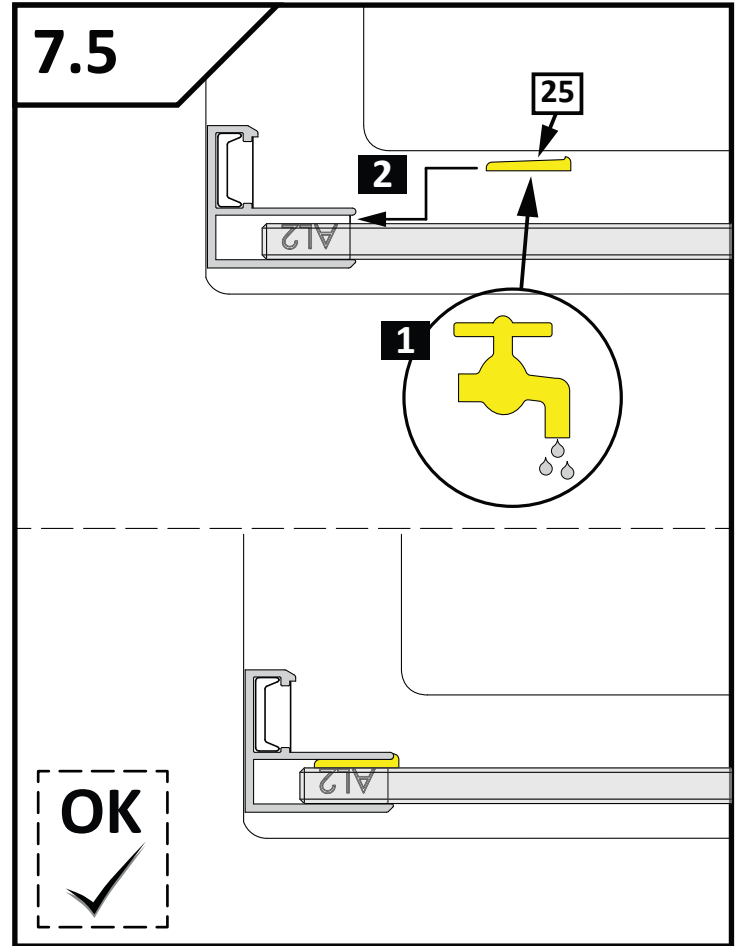
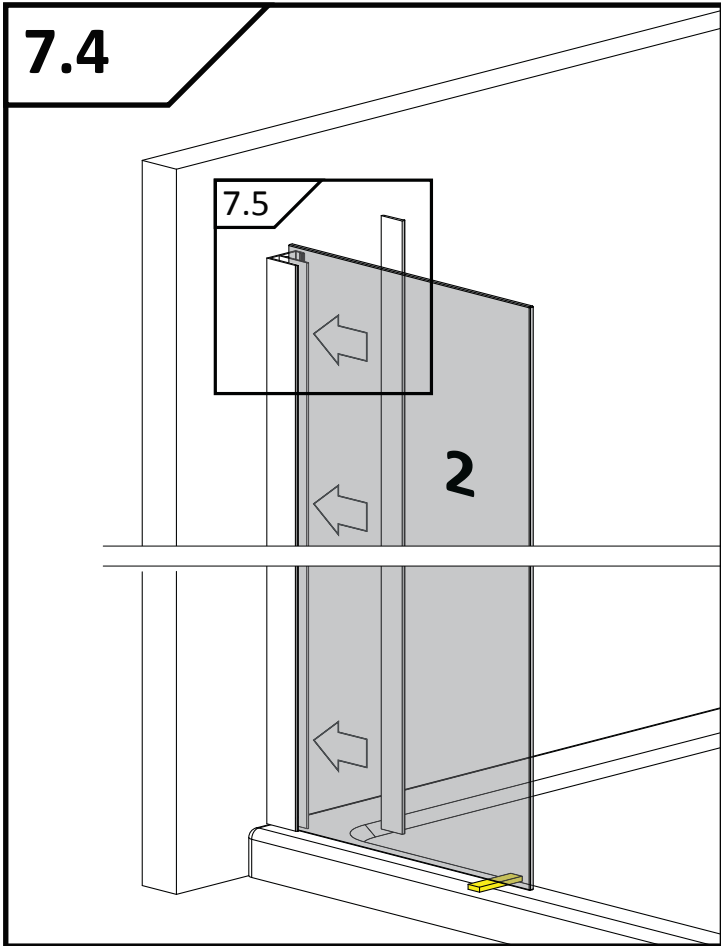

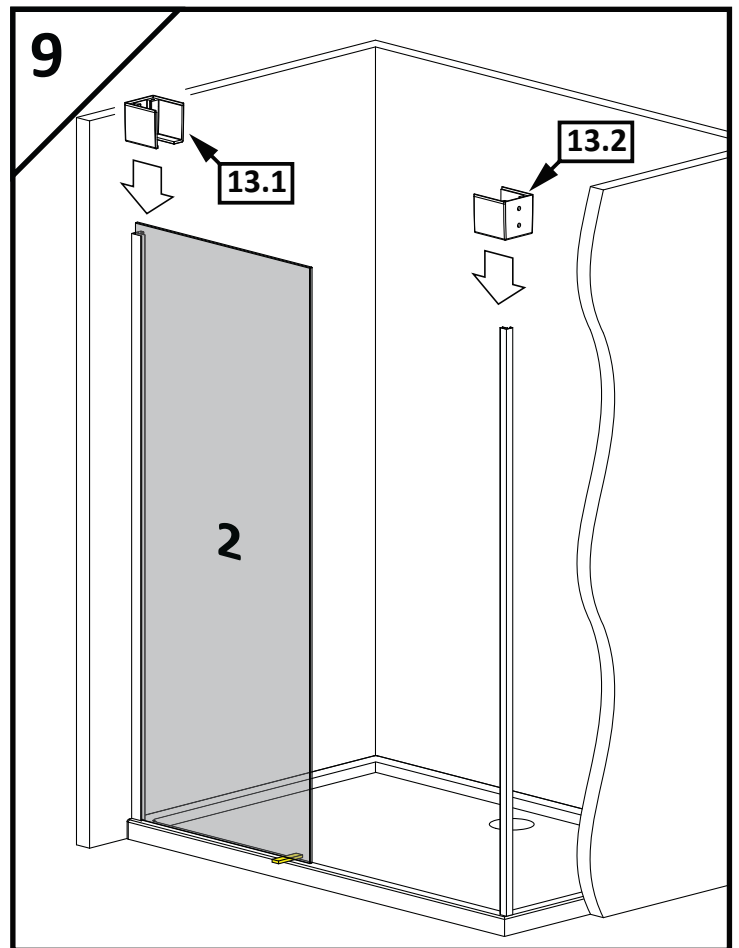
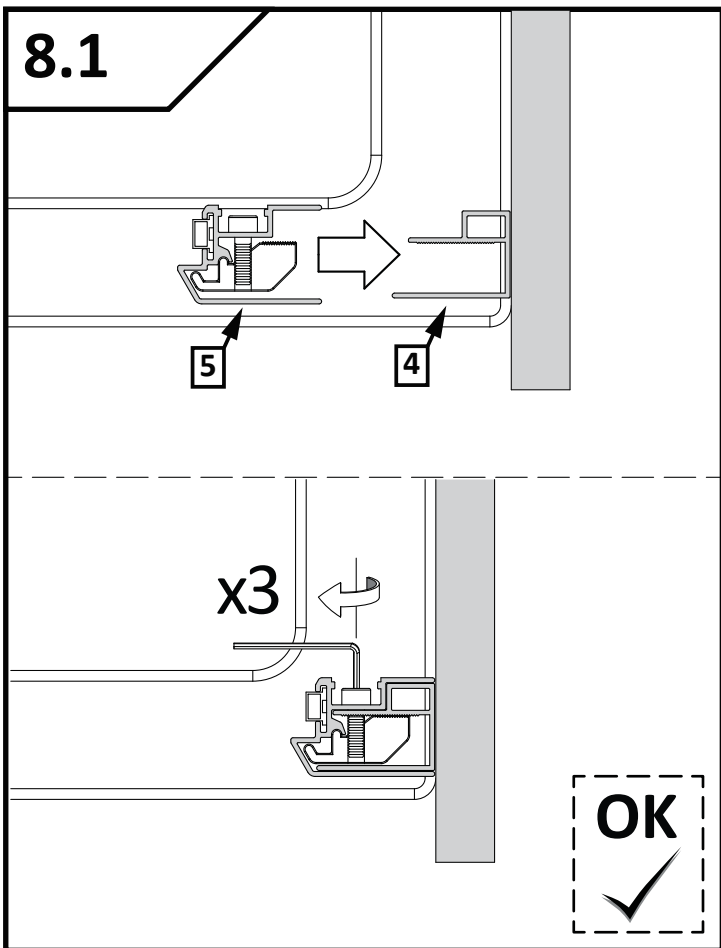
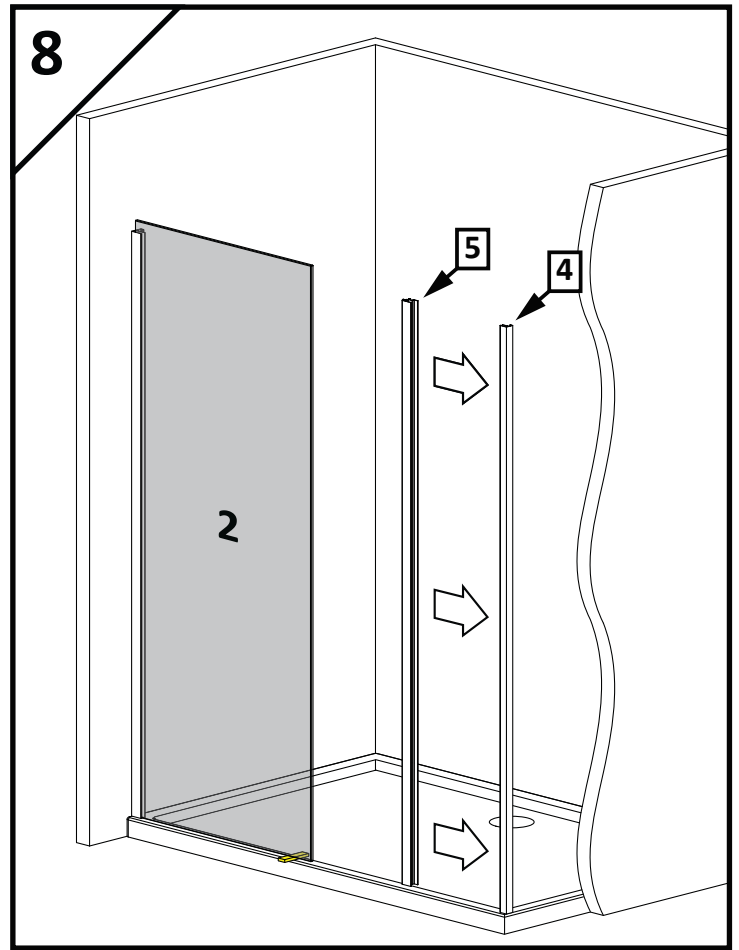
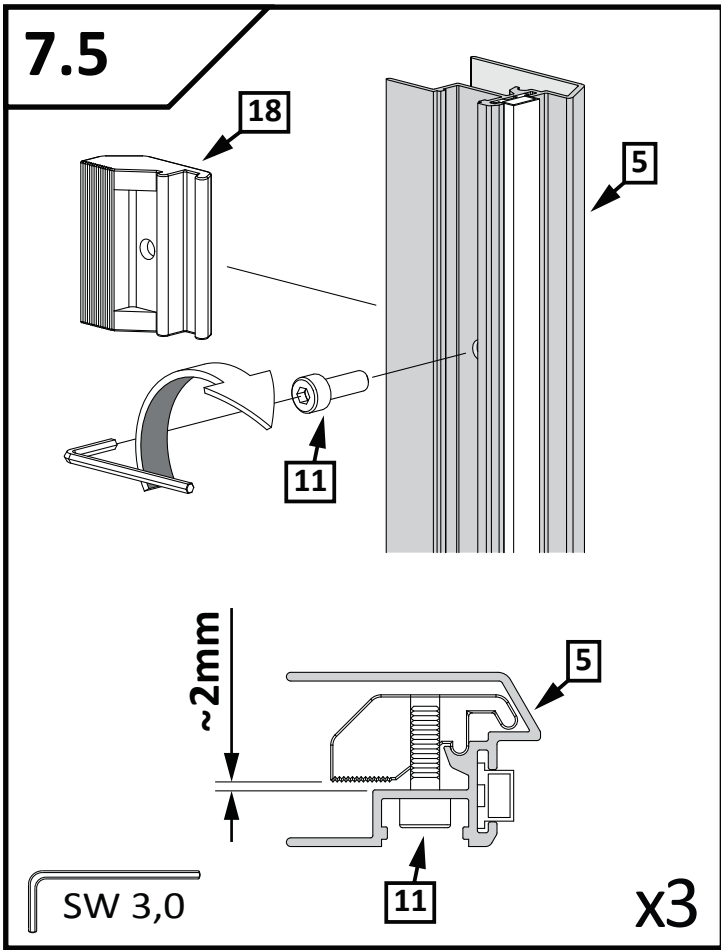

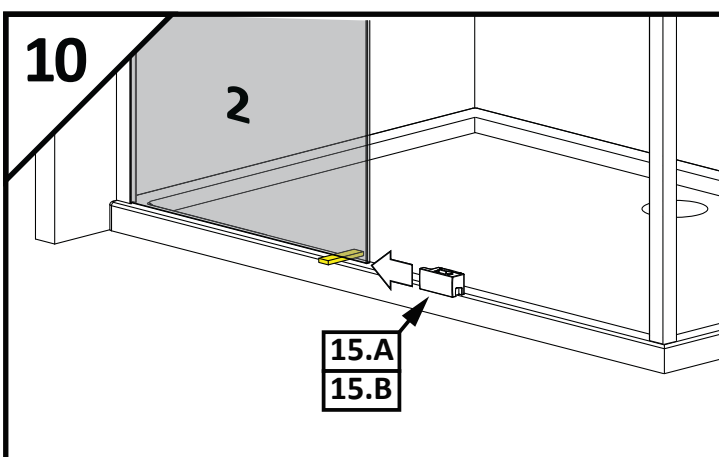
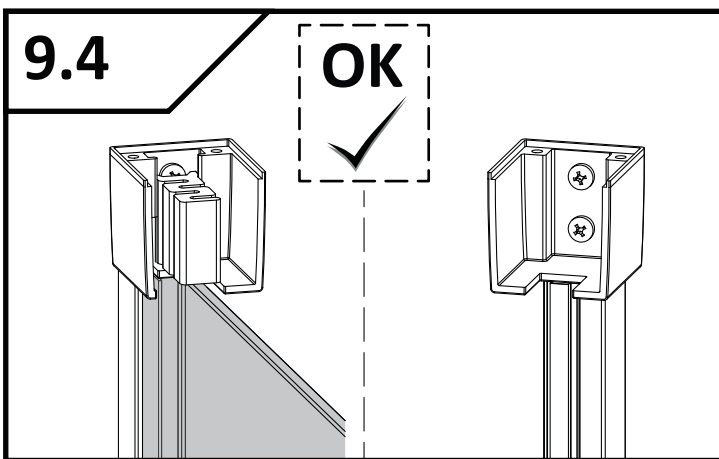
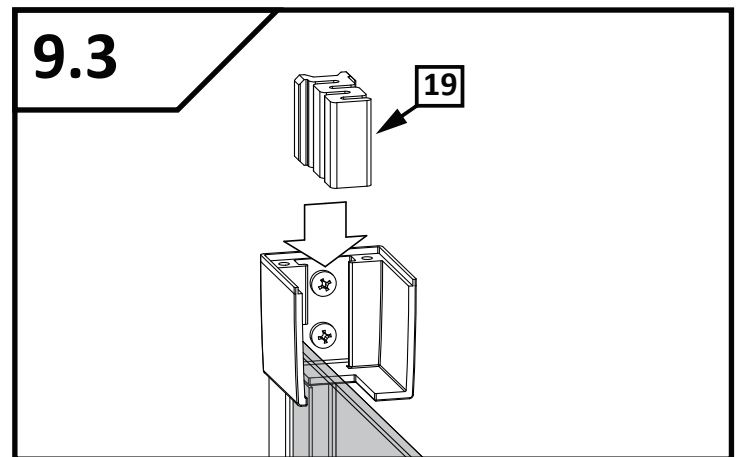
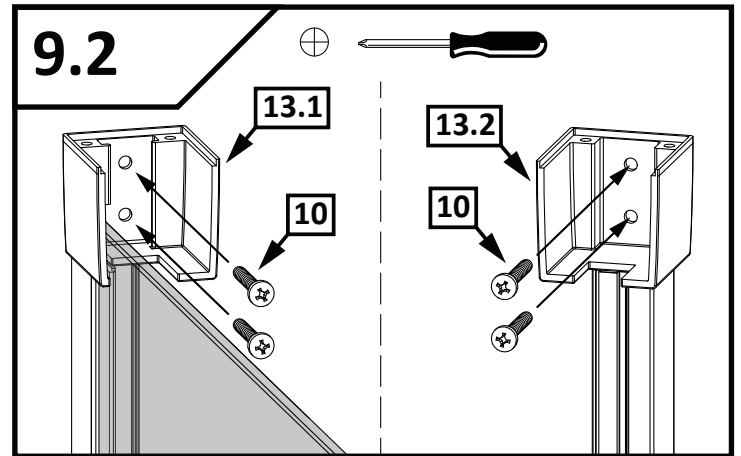
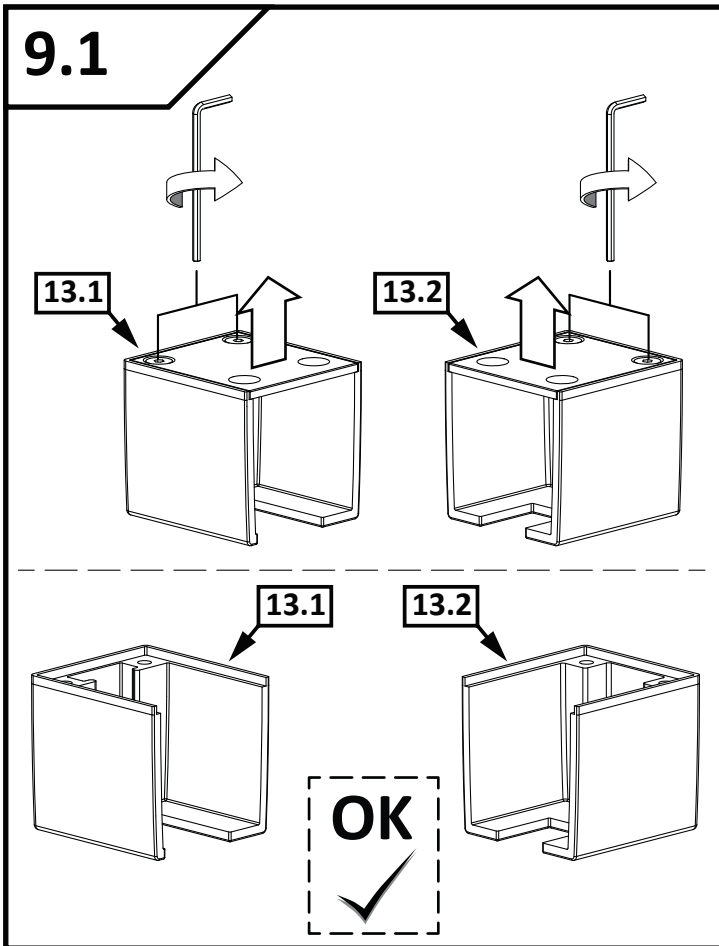

Montaż z listwą progową
Installation with threshold profile
Die Montage mit Schwalleiste
Montovanie s prahovým profilom
Instalace přechodové lišty
Монтаж с профилем порога
Szerelés küszöb profilal
Instalarea cu profil prag

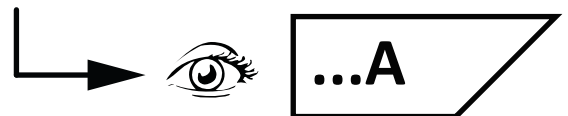

Montaż bez listwy progowej
Installation without threshold profile
Die Montage ohne Schwalleiste
Montovanie bez prahového profilu
Instalace bez prahové lišty
Монтаж без профиля порога
Szerelés küszöb profil nélkül
Instalarea fara profil prag

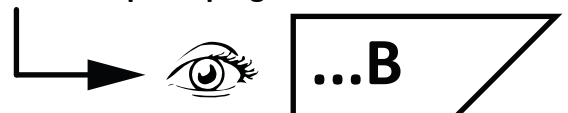

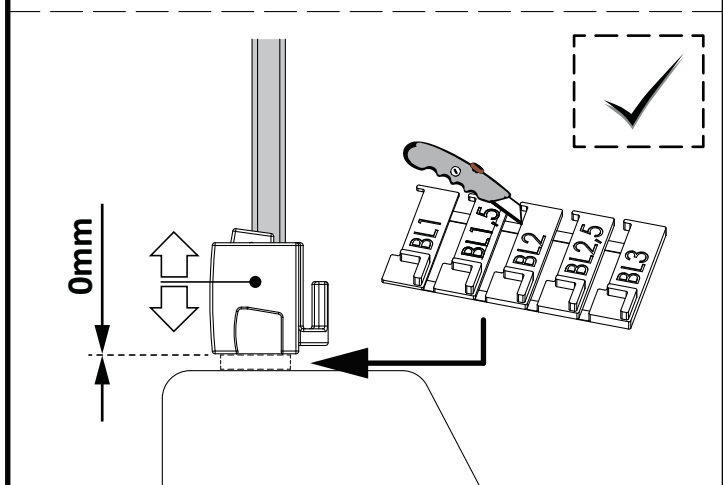
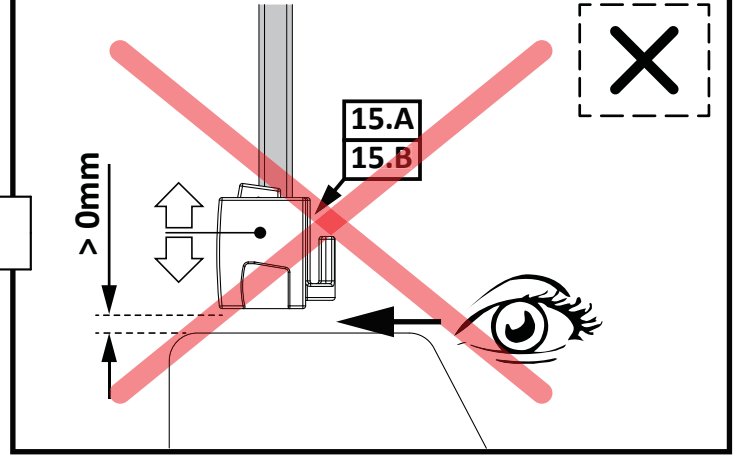
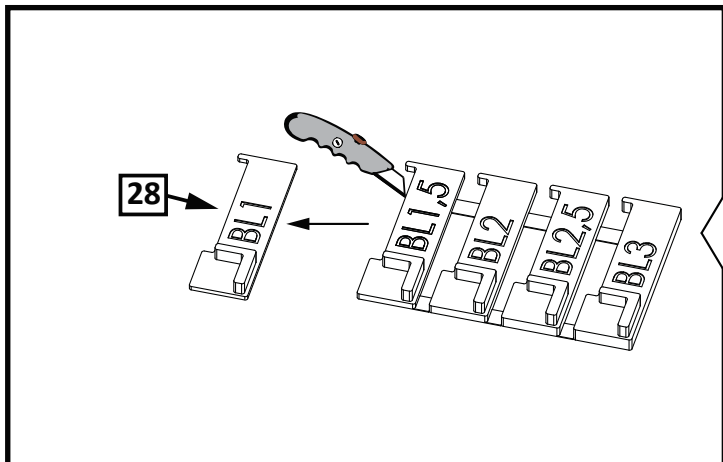
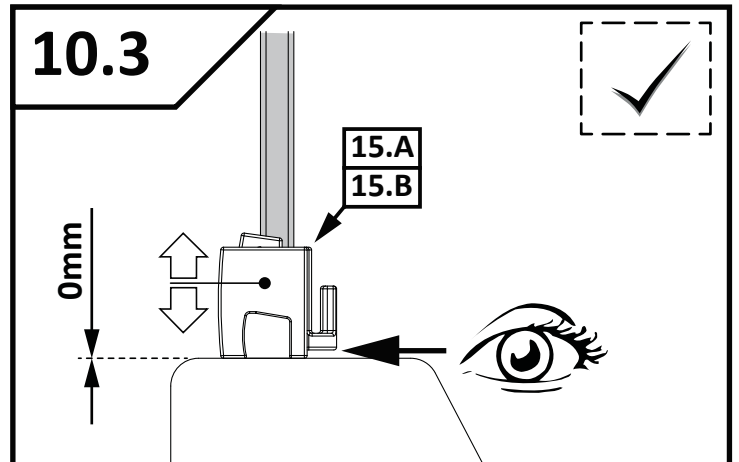
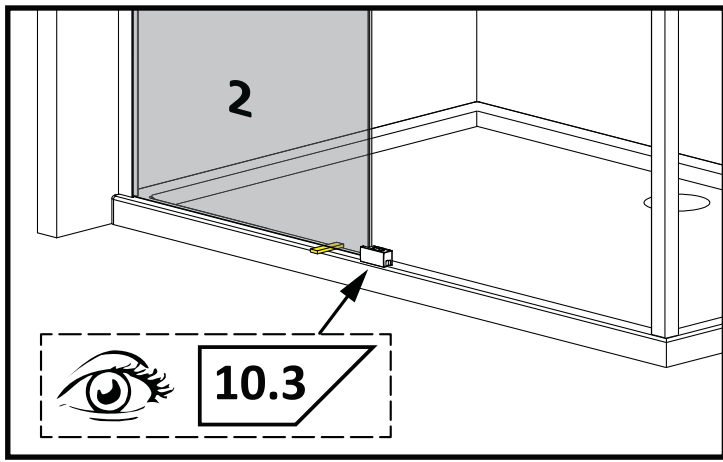
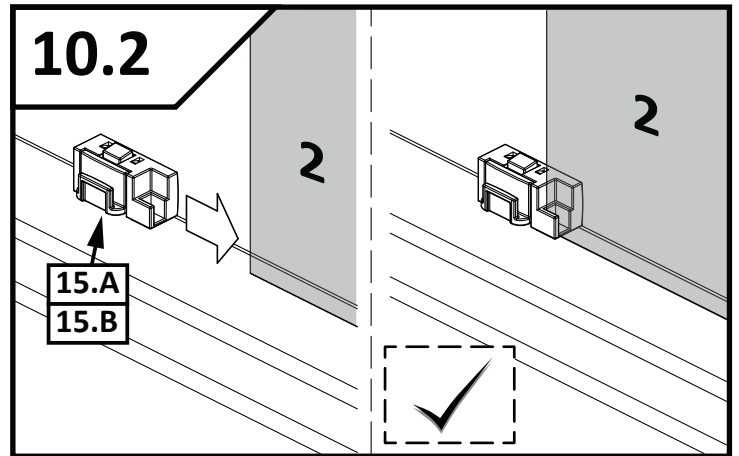
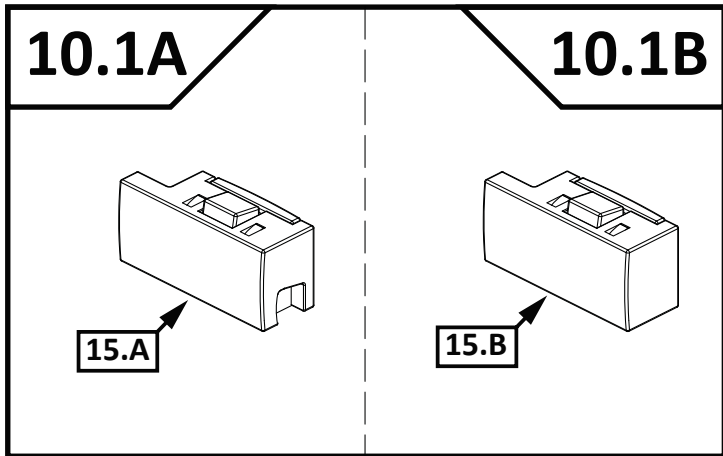

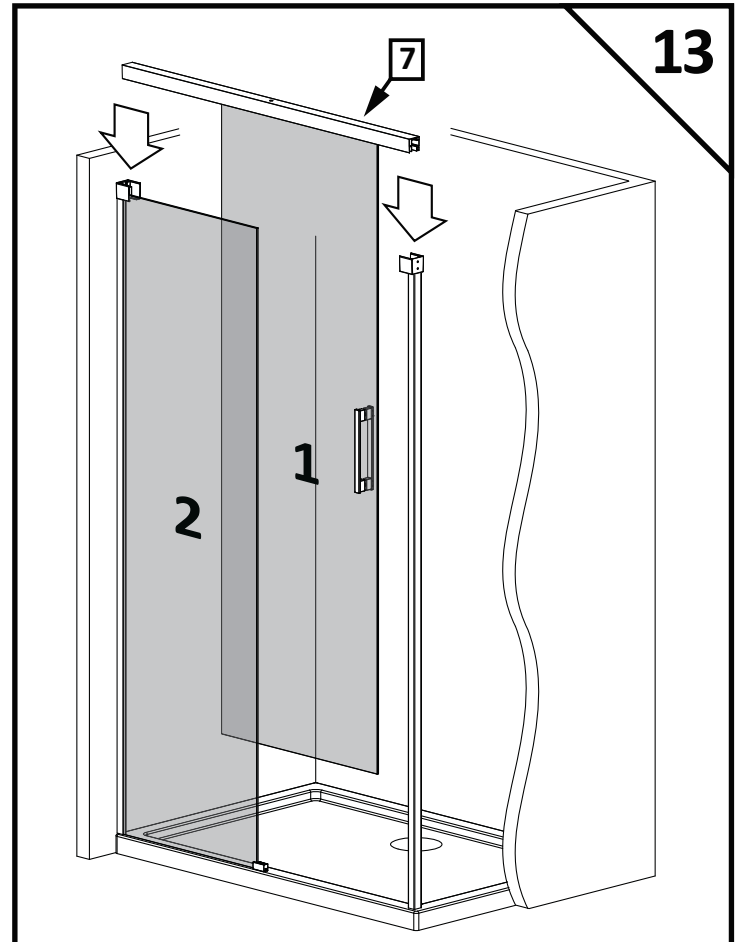
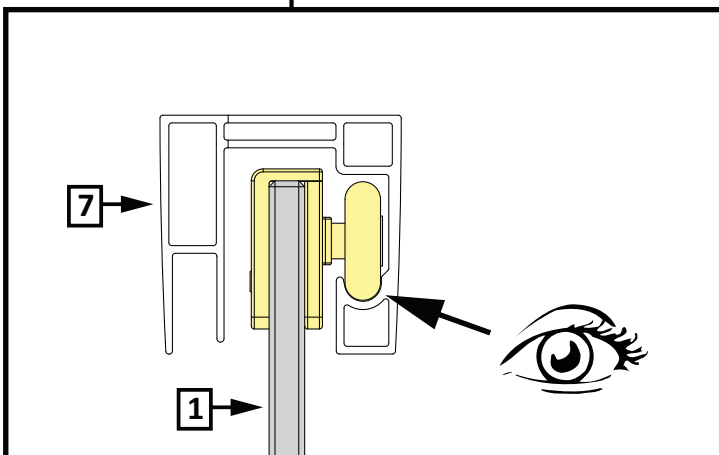
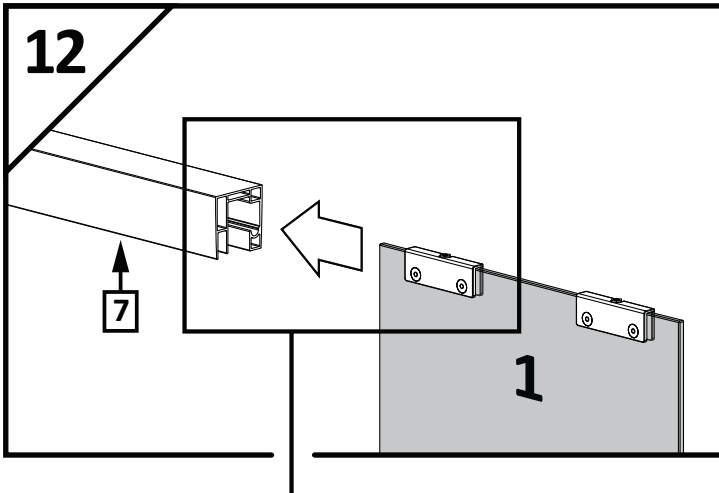
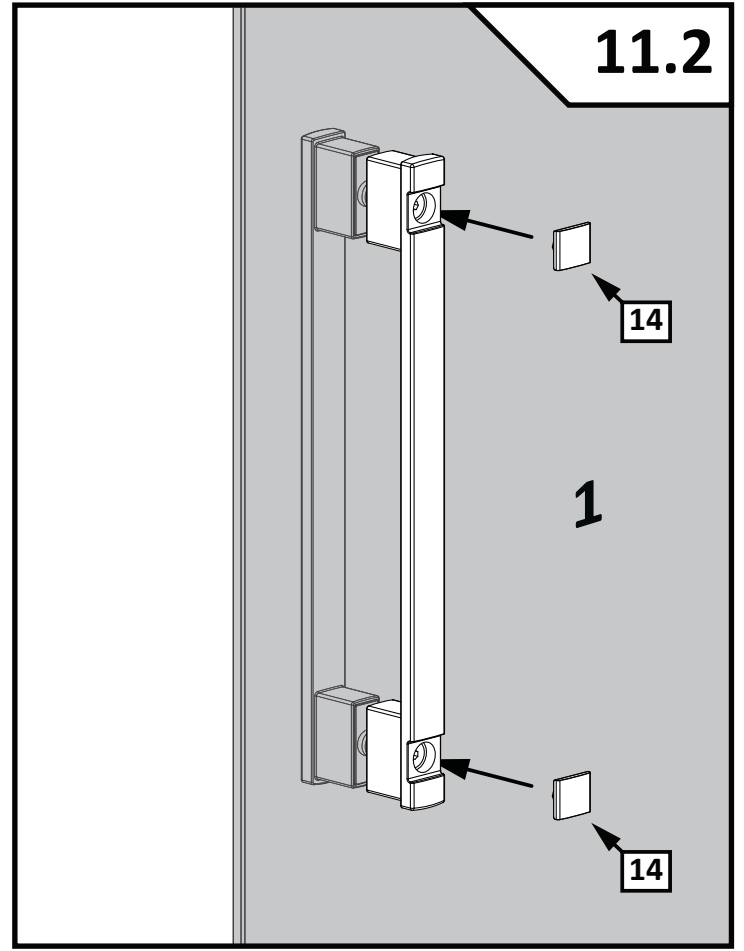
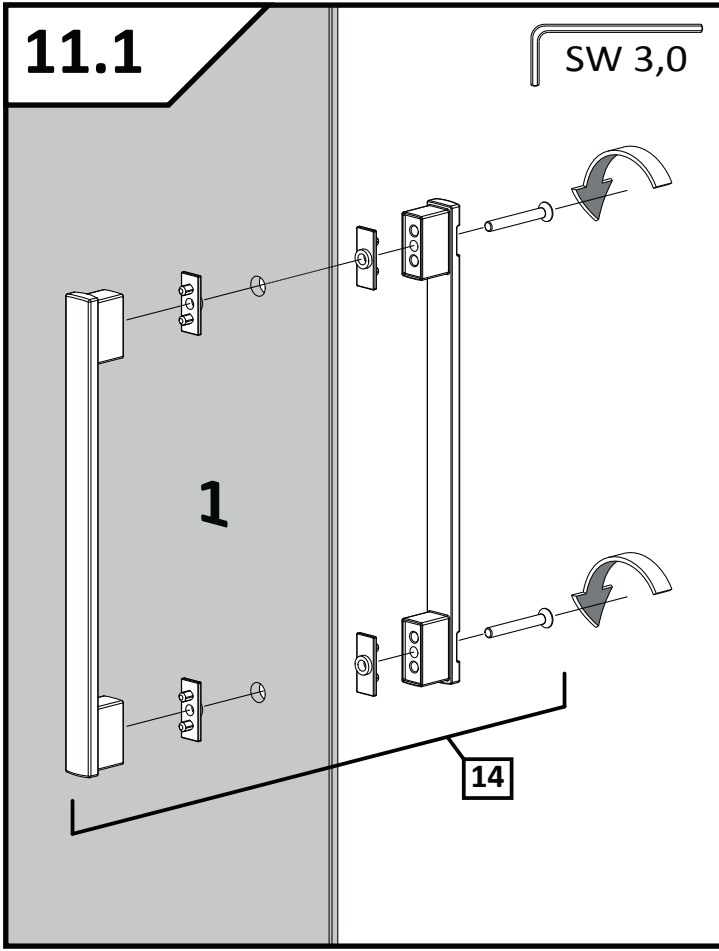

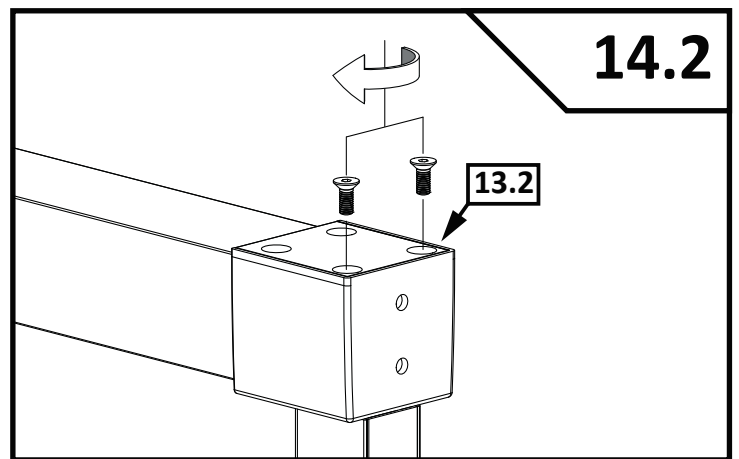
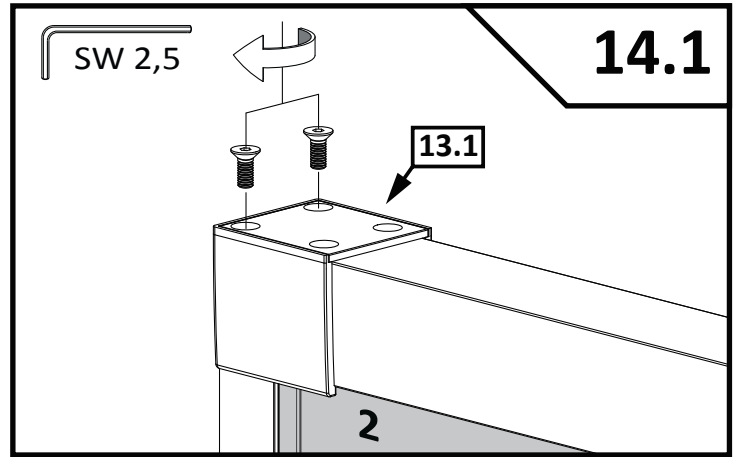
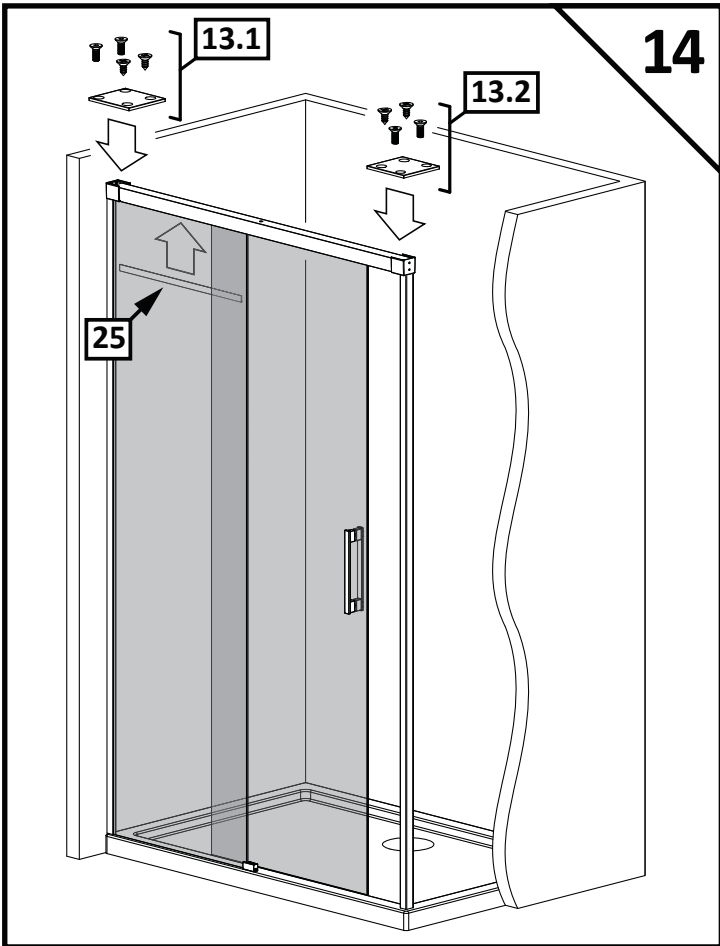
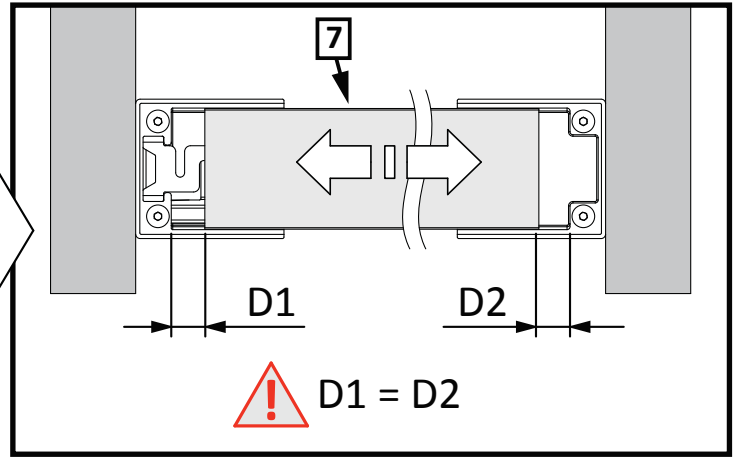
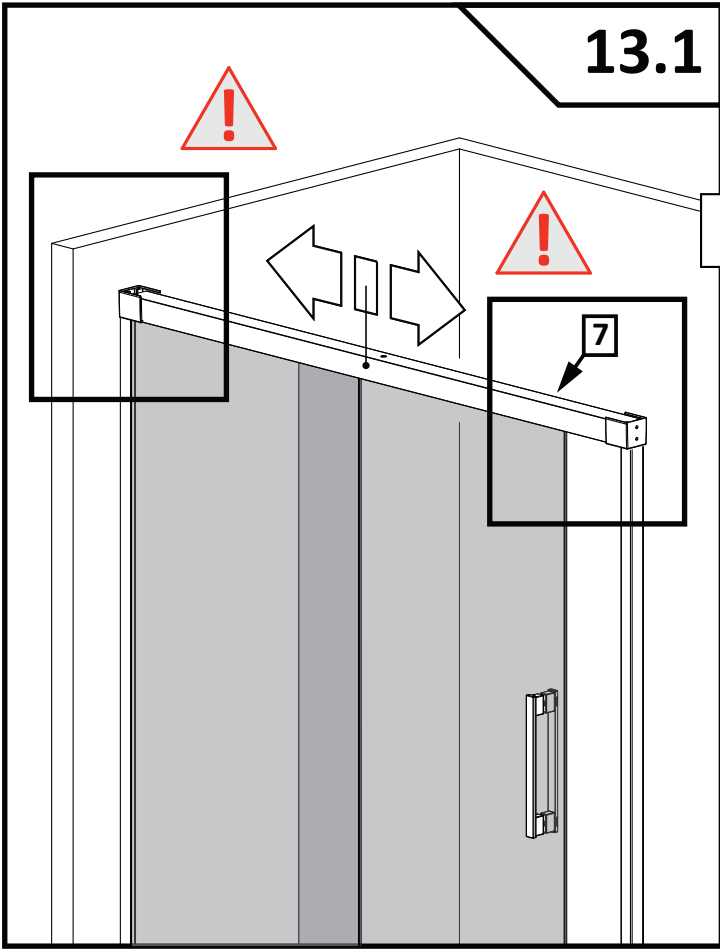

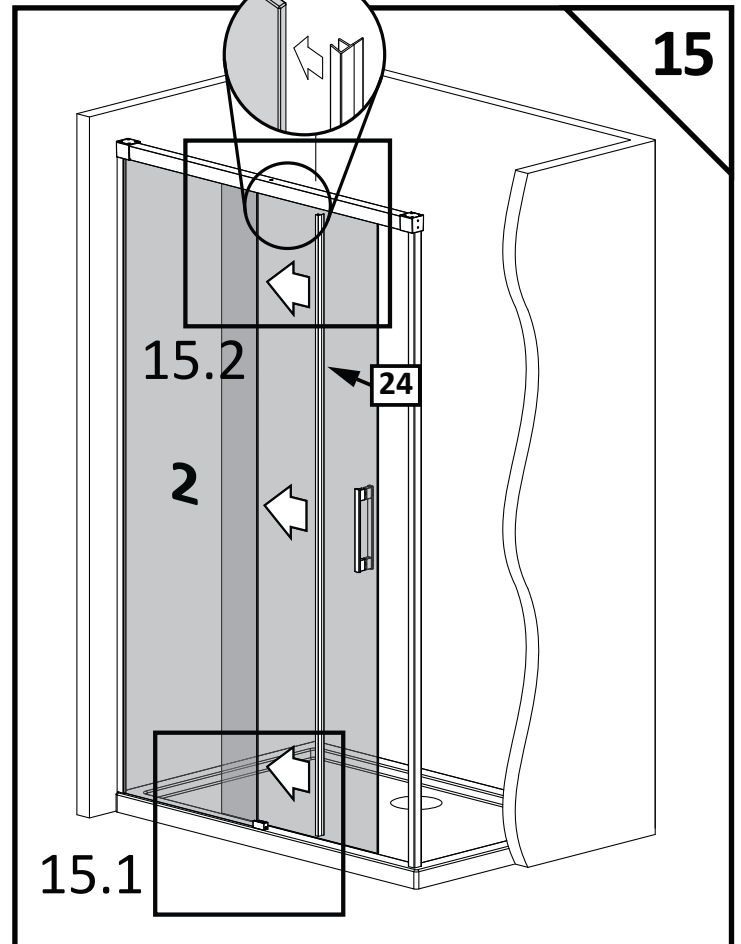
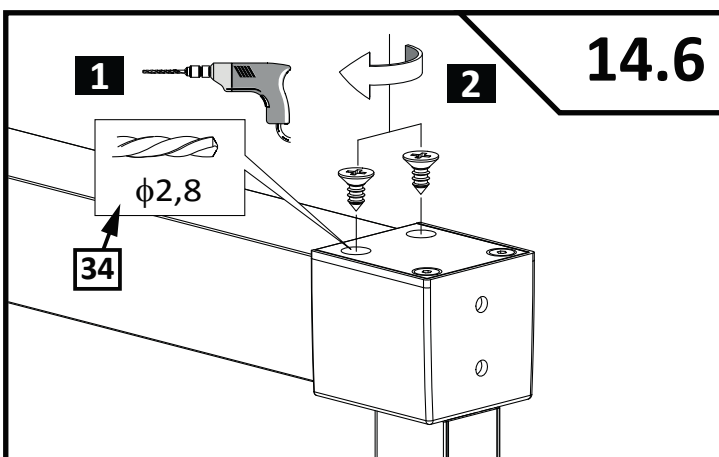
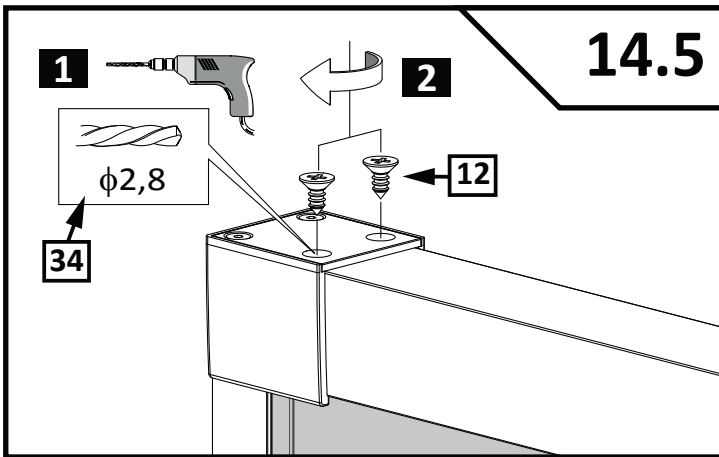
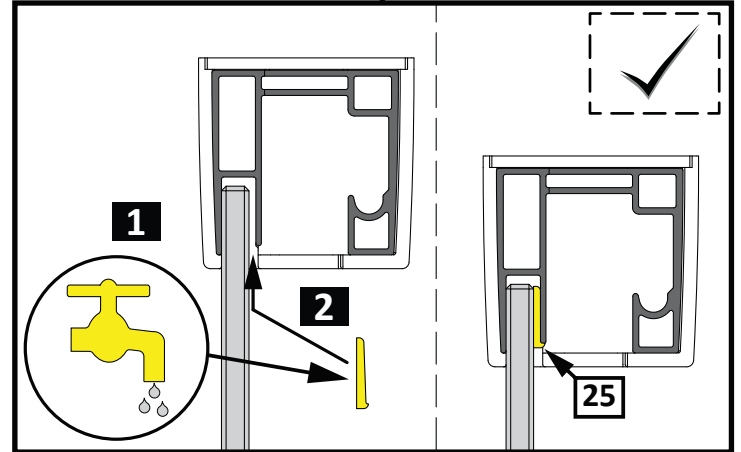
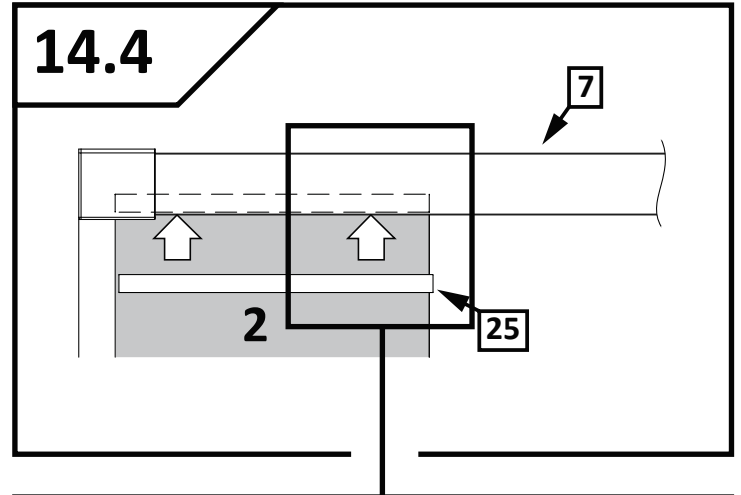
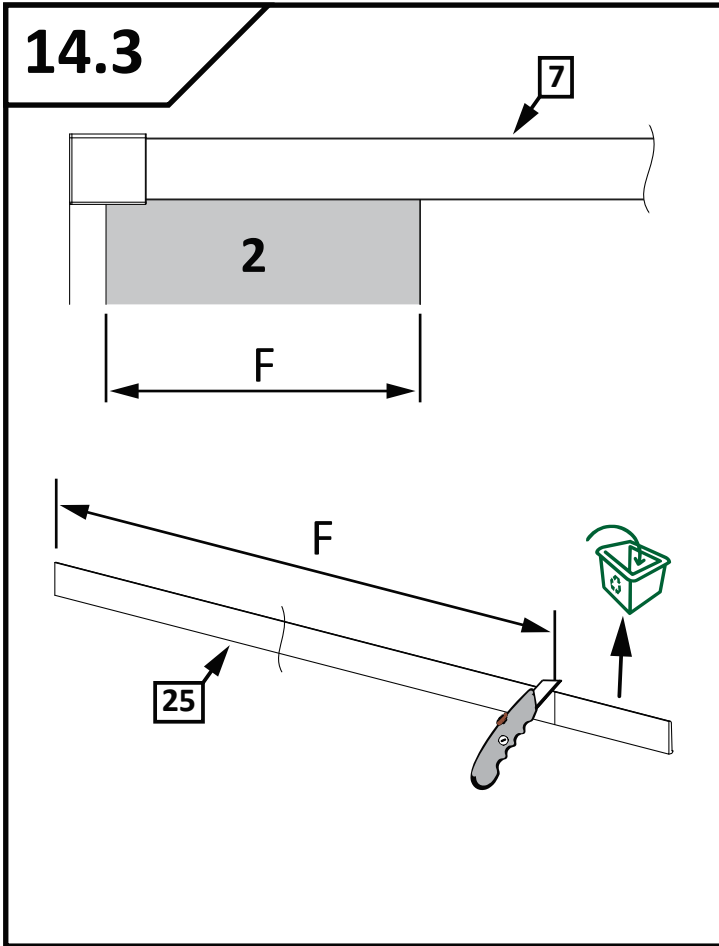

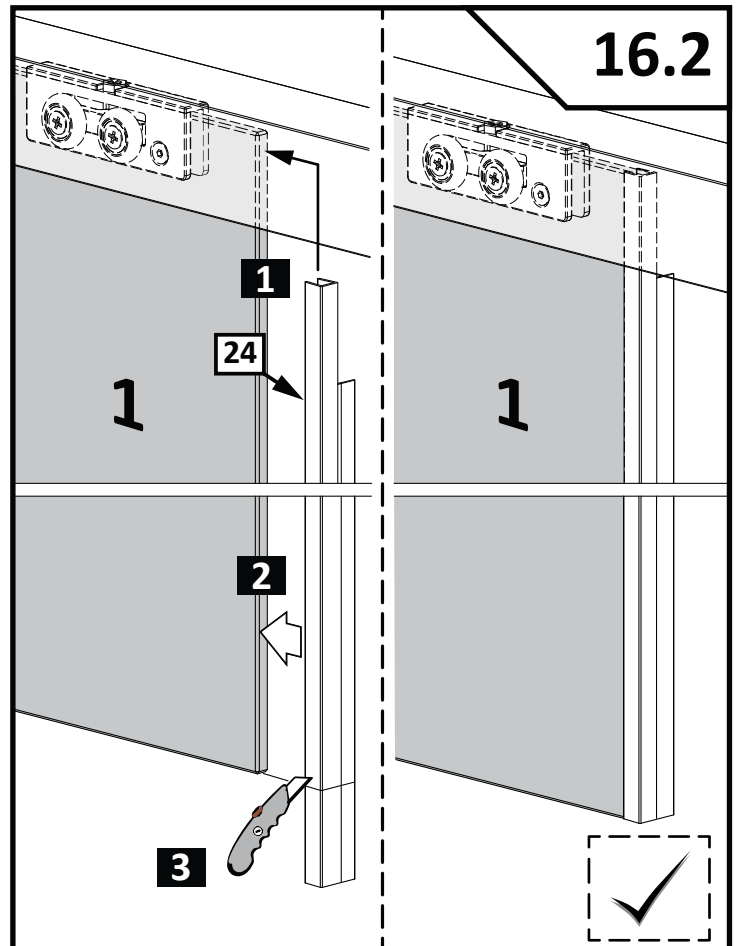
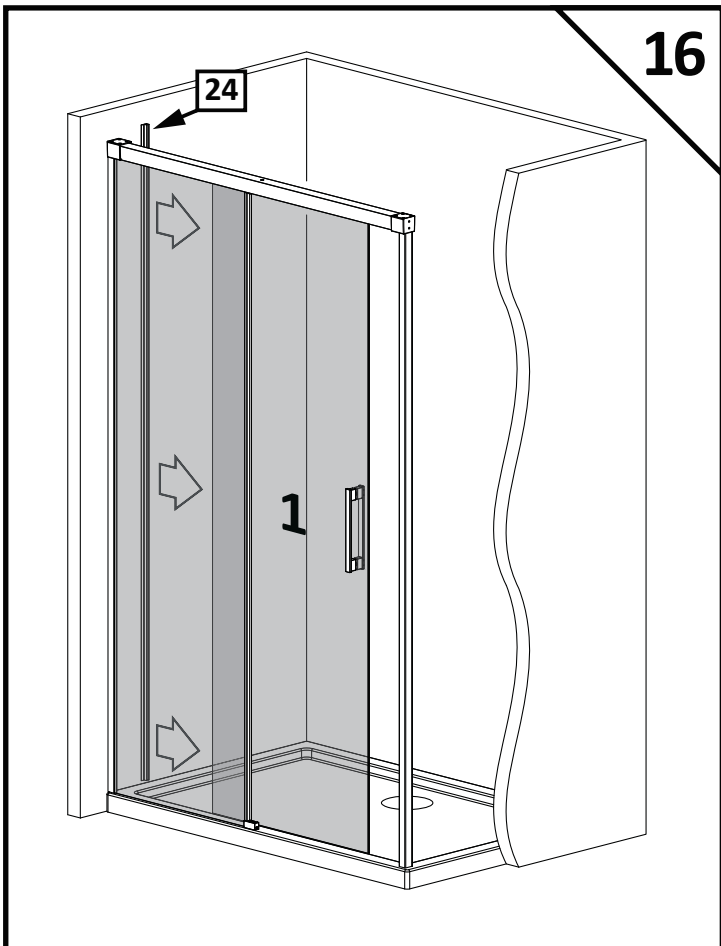
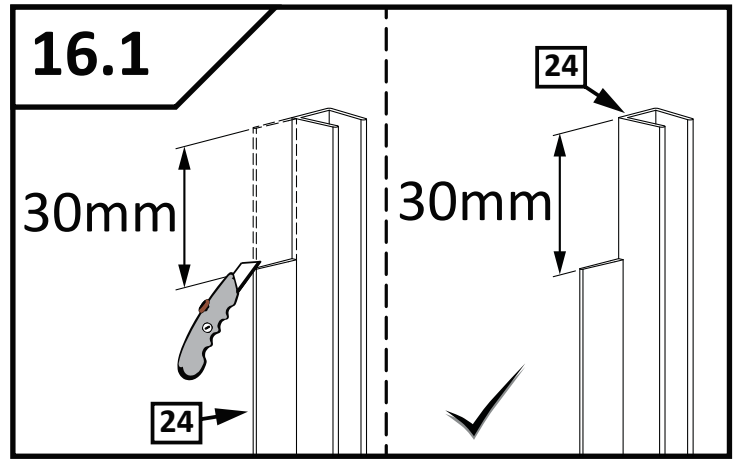
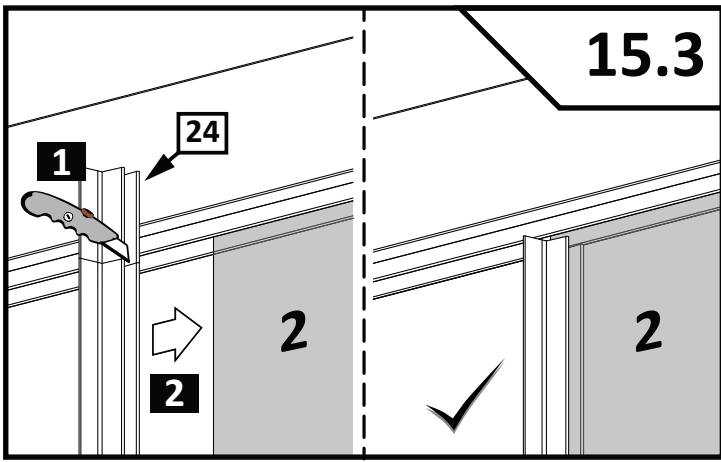
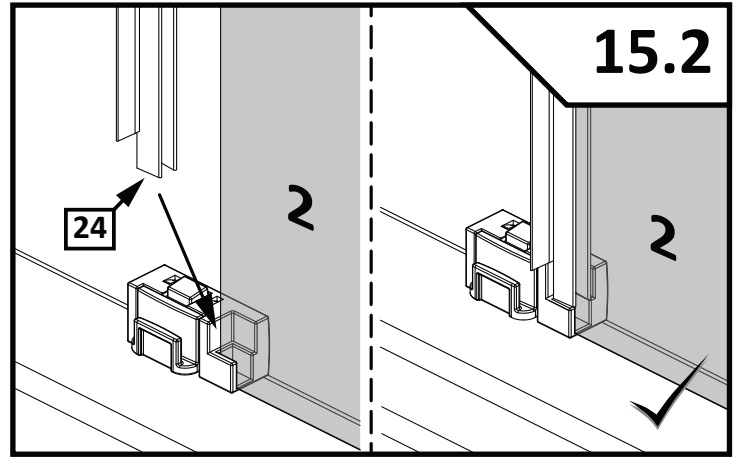
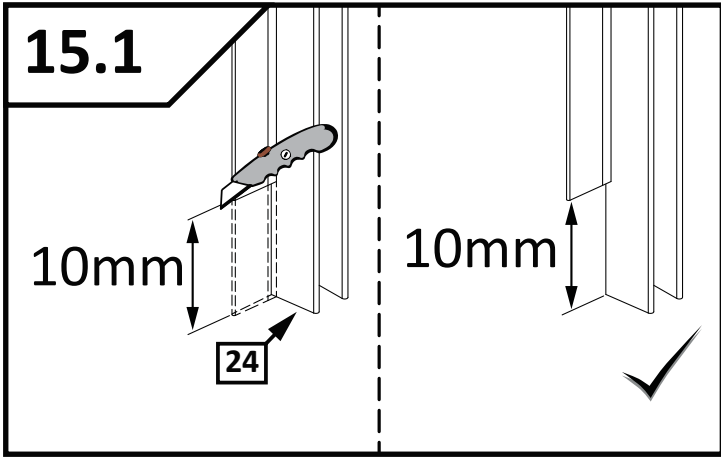

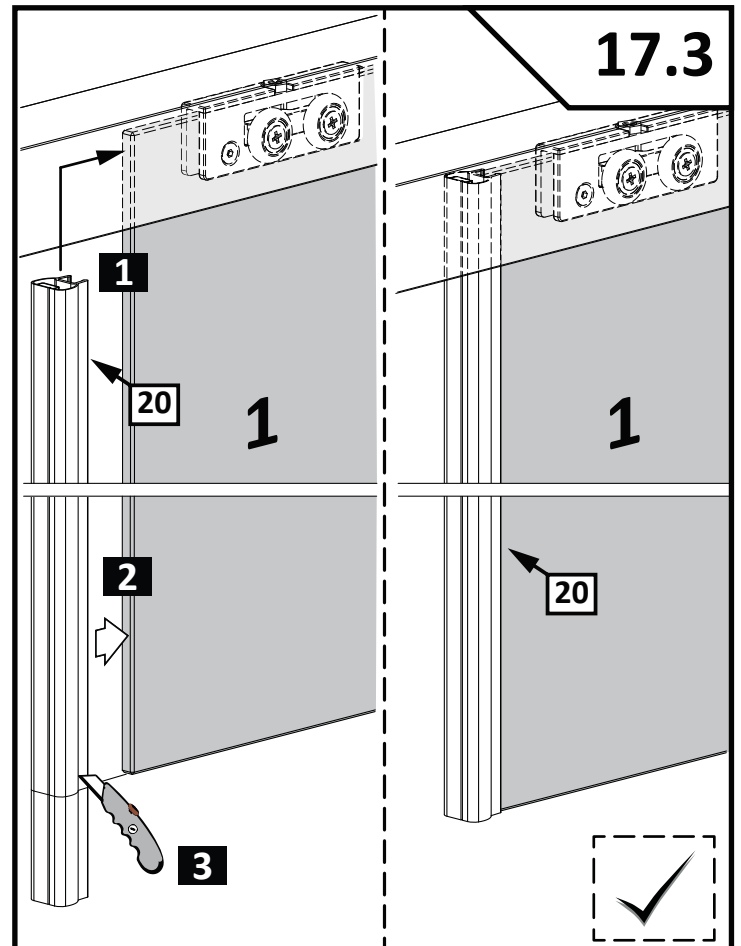
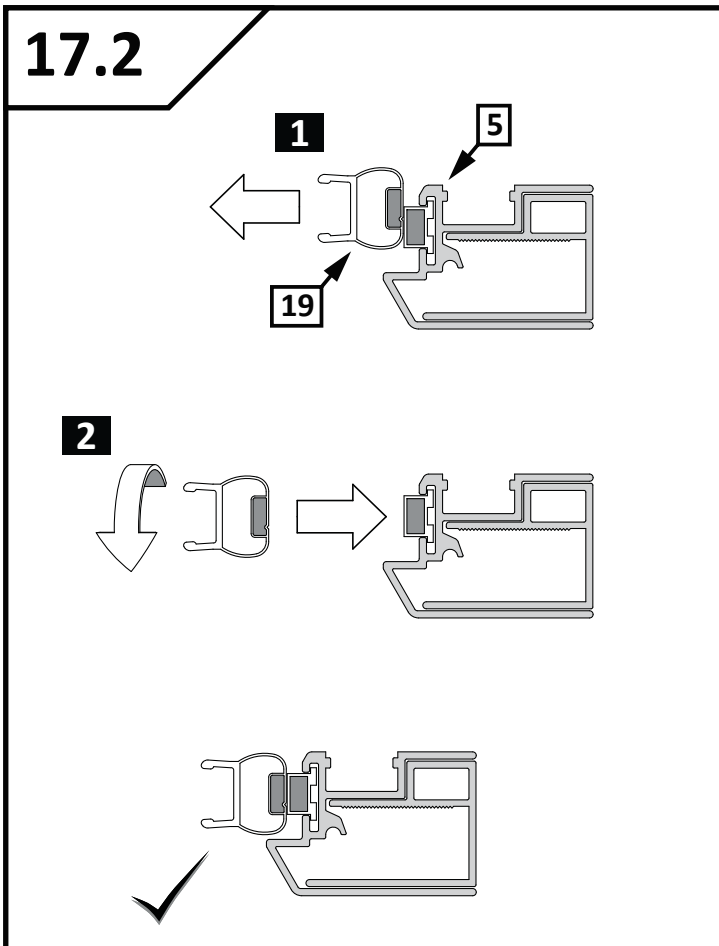
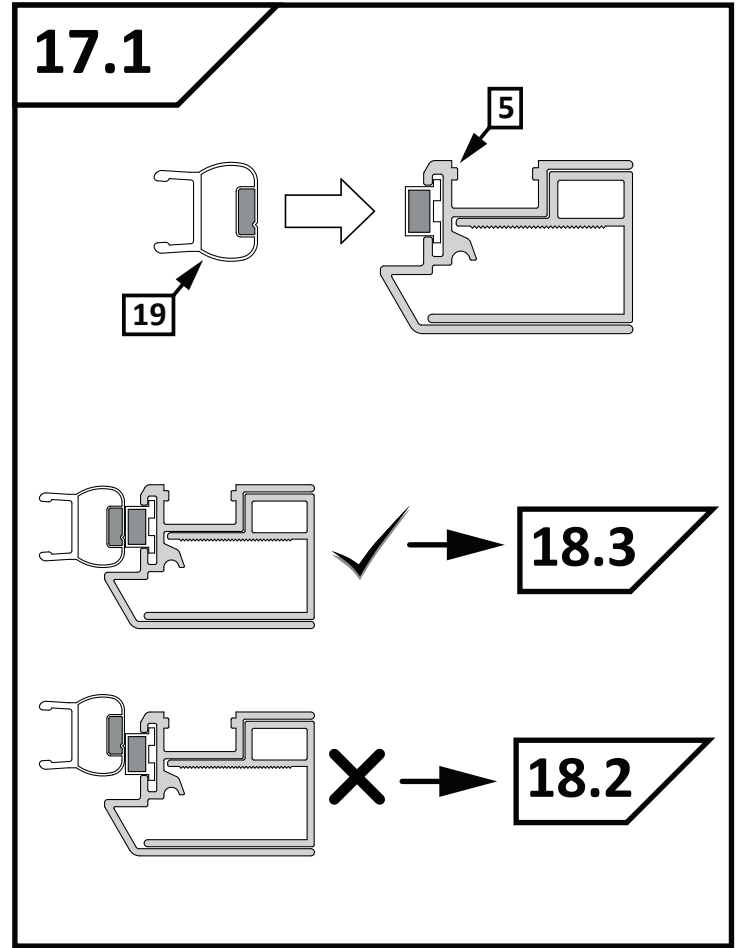
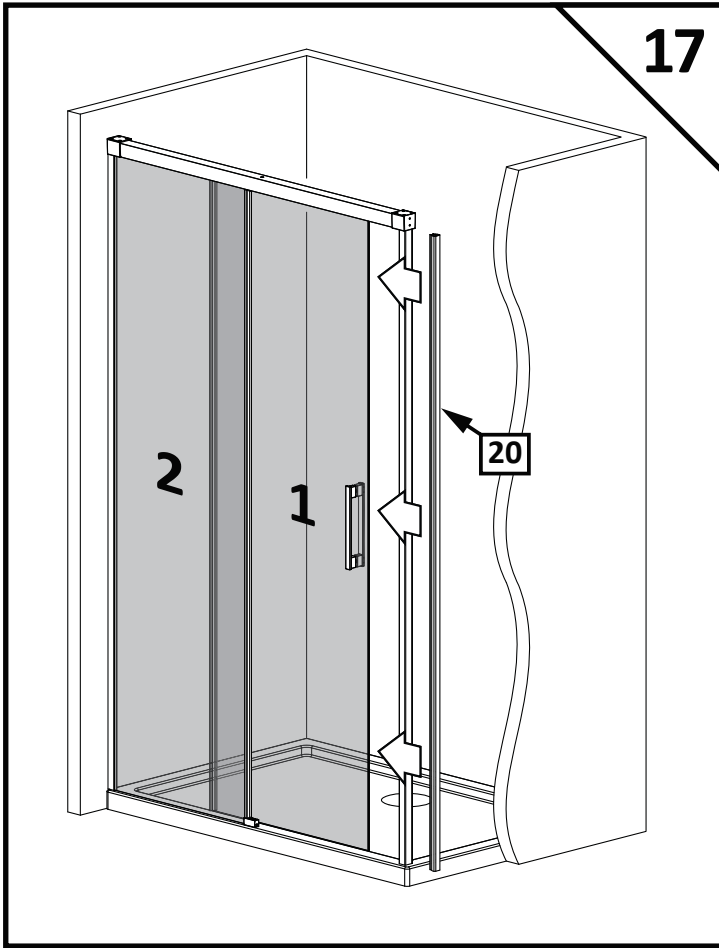

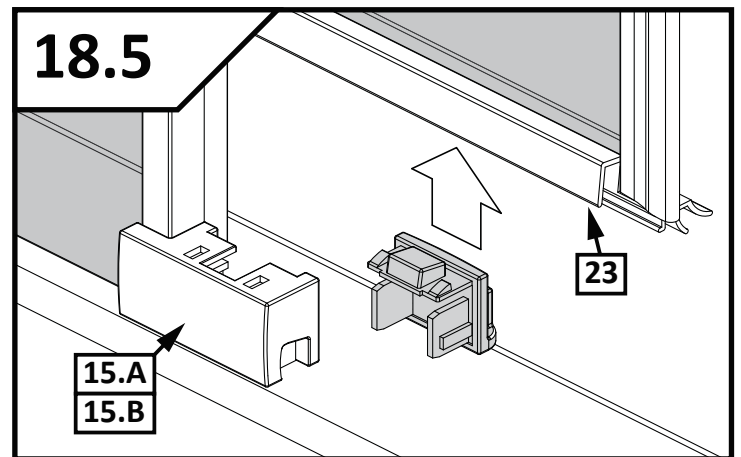
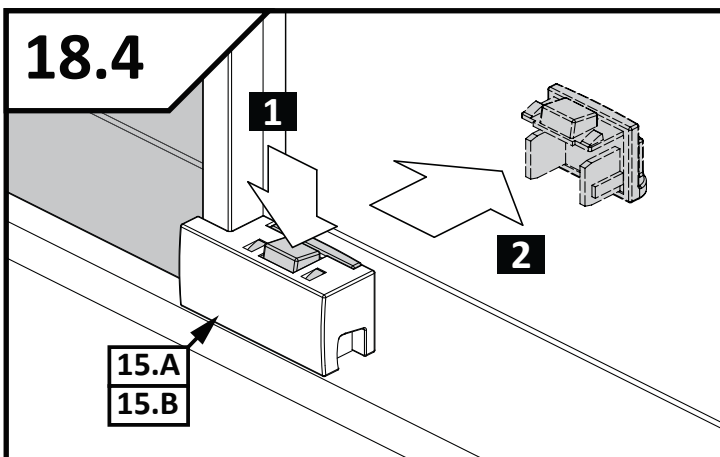
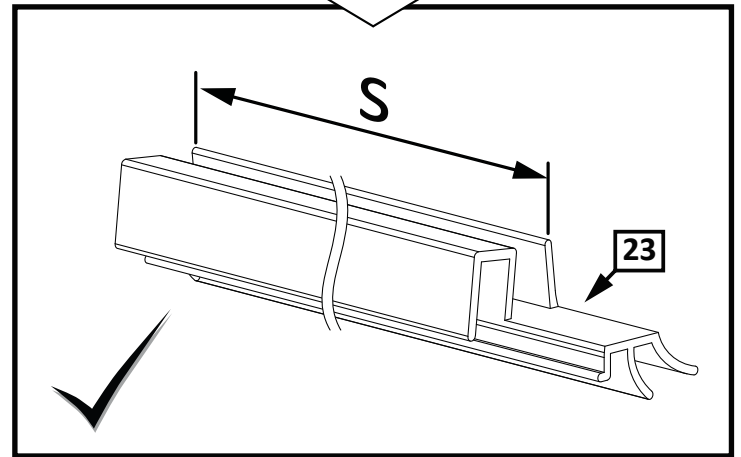
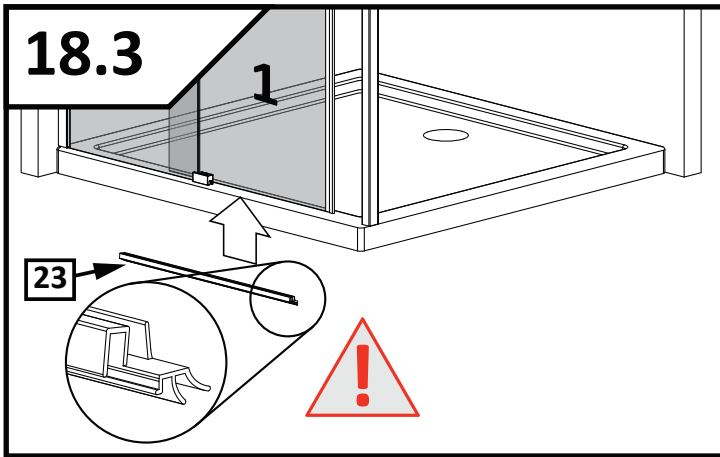
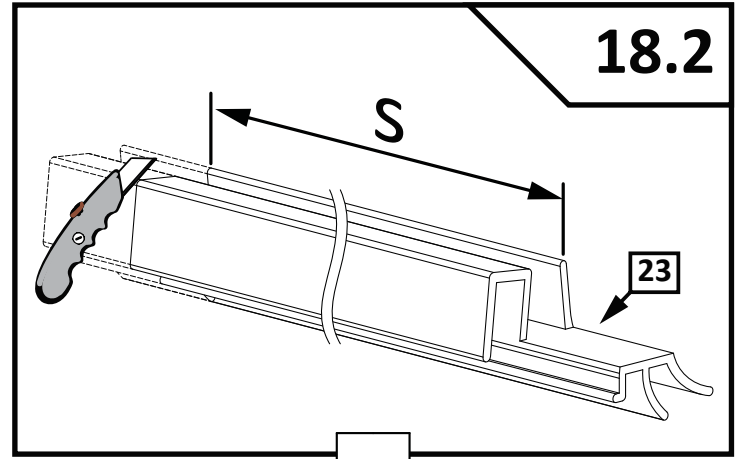
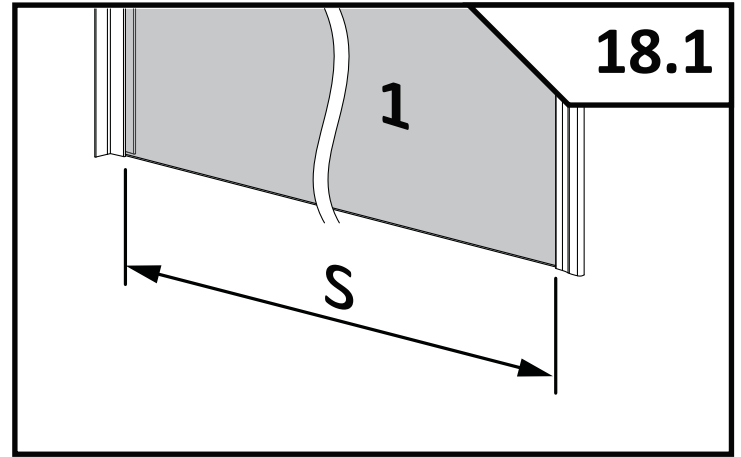
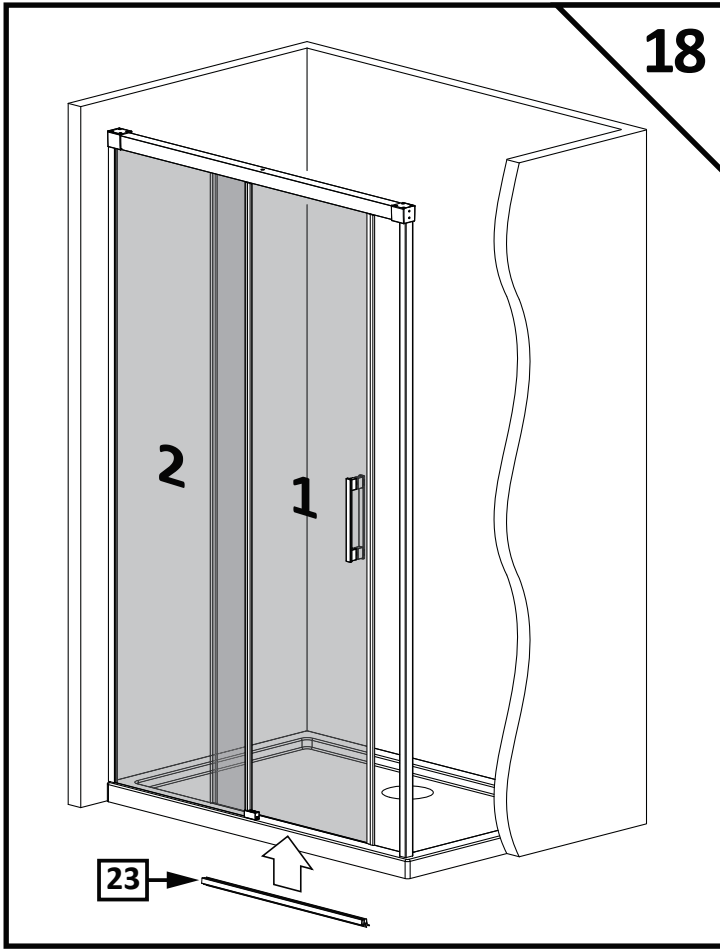

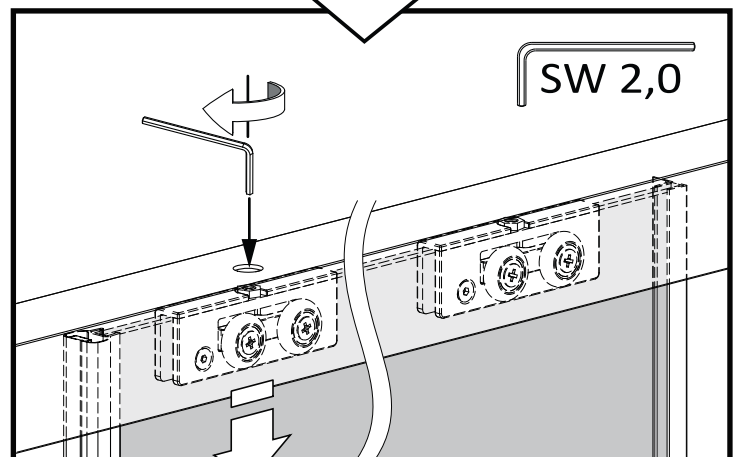
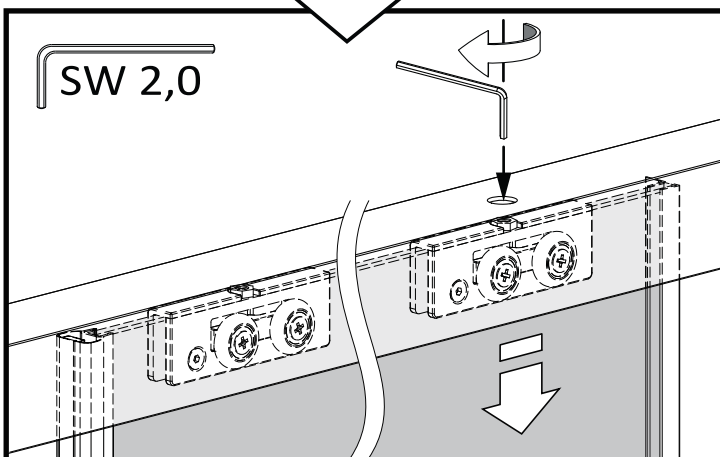
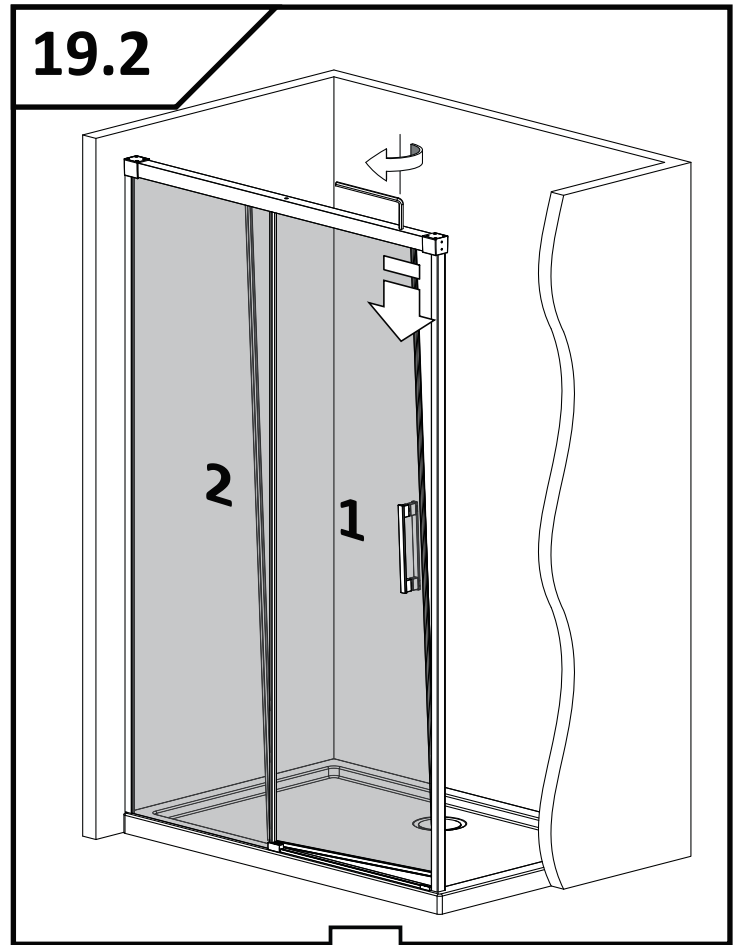
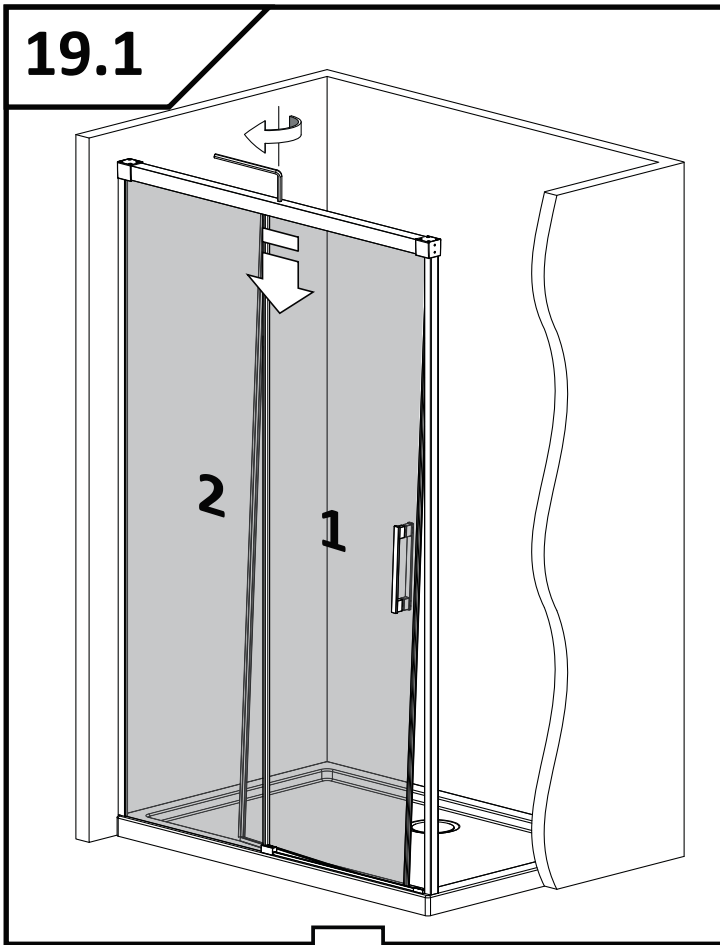
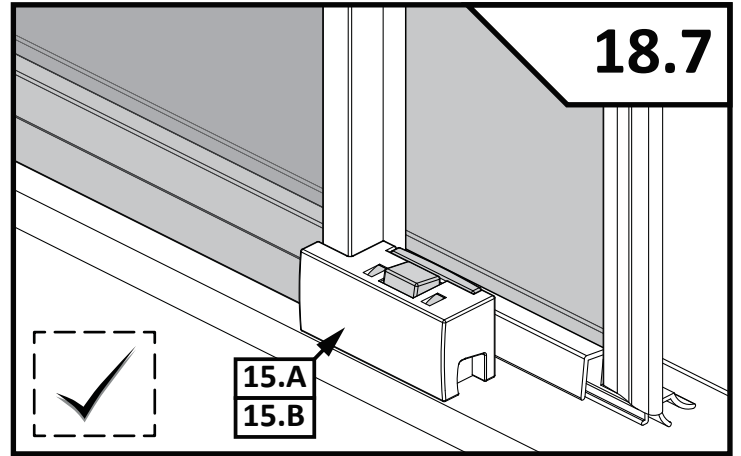
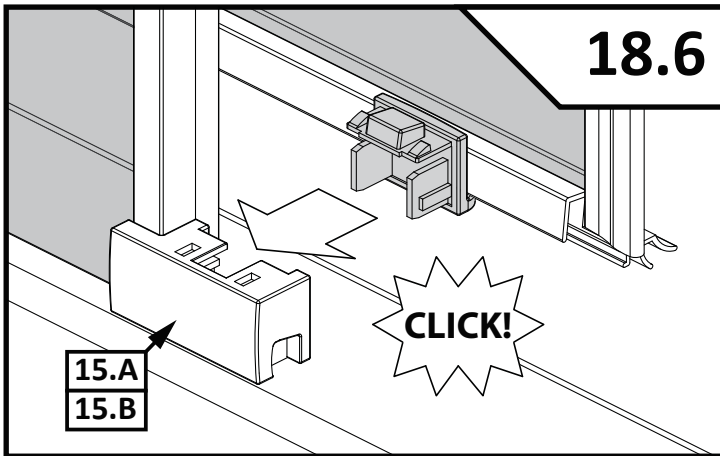

19.3

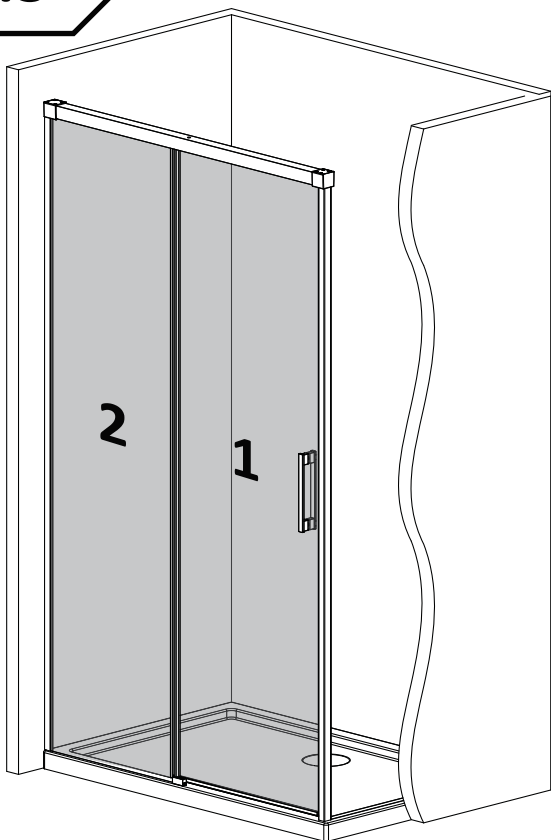

Montaż z listwą progową
Installation with threshold profile
Die Montage mit Schwalleiste
Montovanie s prahovým profilom
Instalace přechodové lišty
Монтаж с профилем порога
Szerelés küszöb profillal
Instalarea cu profil prag

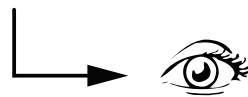

21

Montaż bez listwy progowej
Installation without threshold profile
Die Montage ohne Schwalleiste
Montovanie bez prahového profilu
Instalace bez prahové lišty
Монтаж без профиля порога
Szerelés küszöb profil nélkül
Instalarea fara profil prag

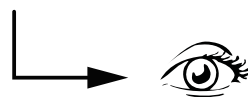

22

20

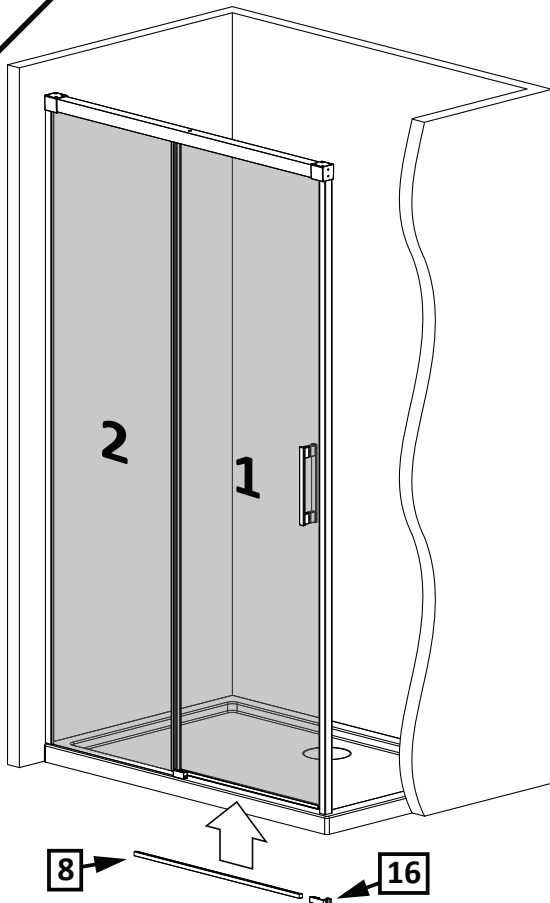

20.1

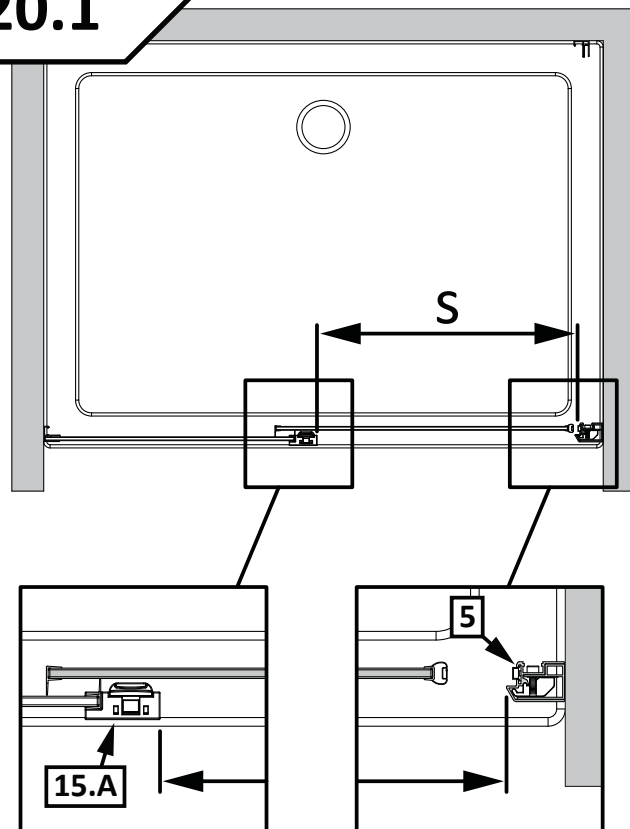

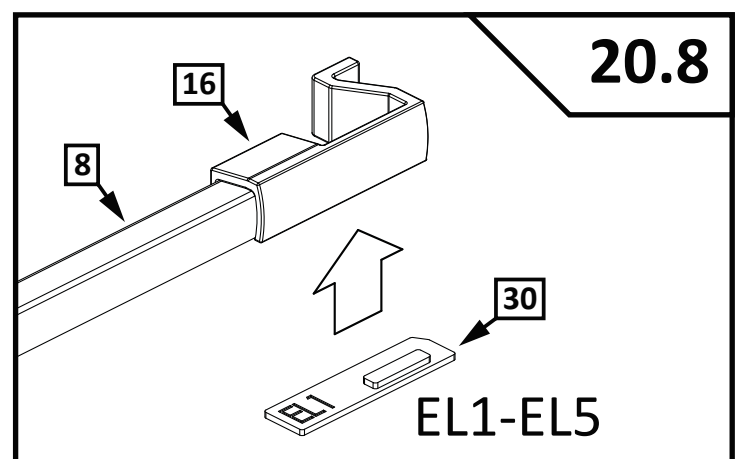
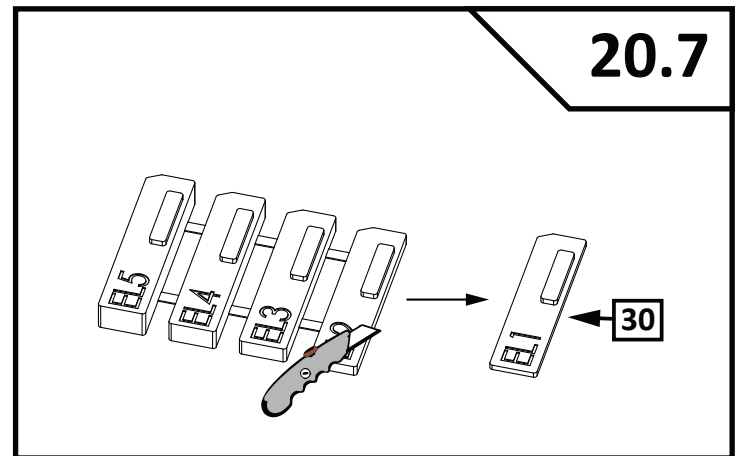
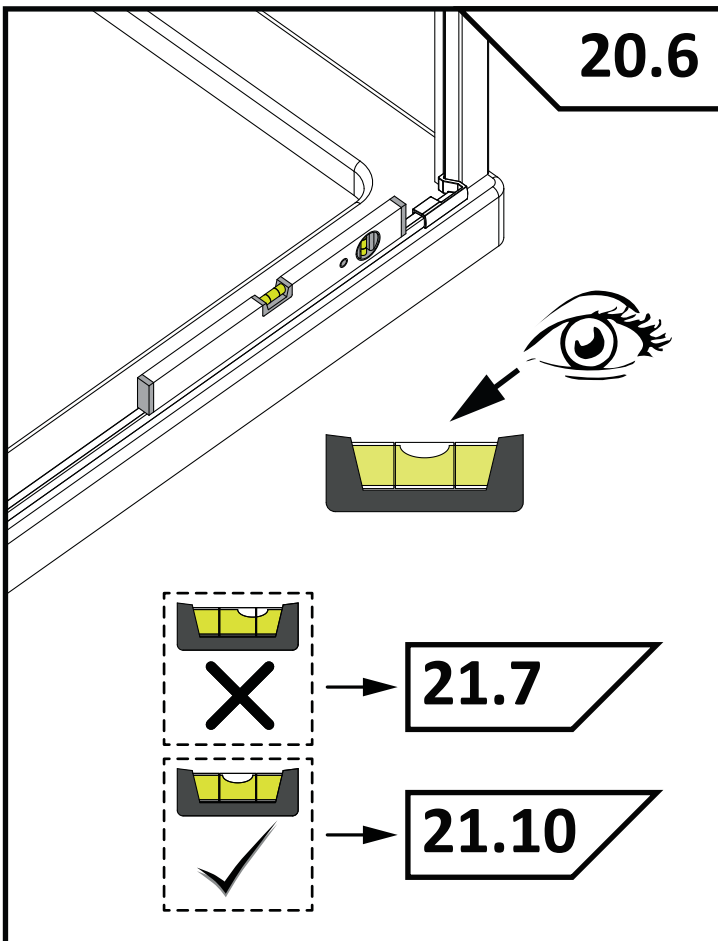
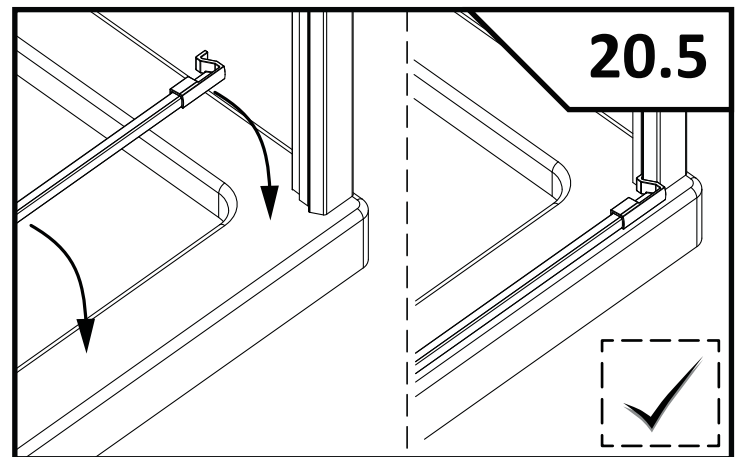
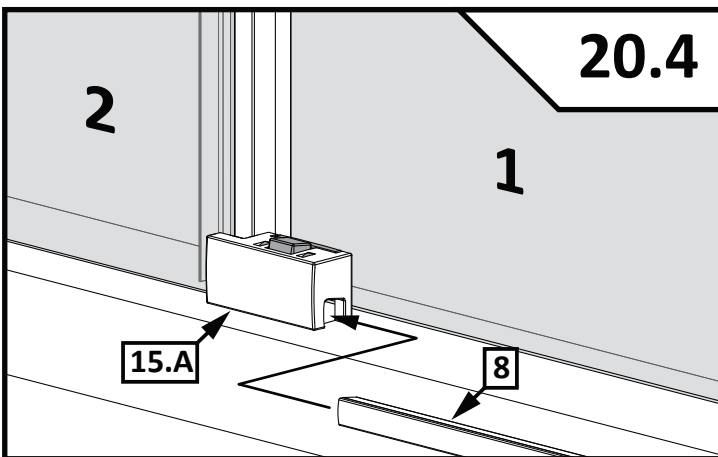
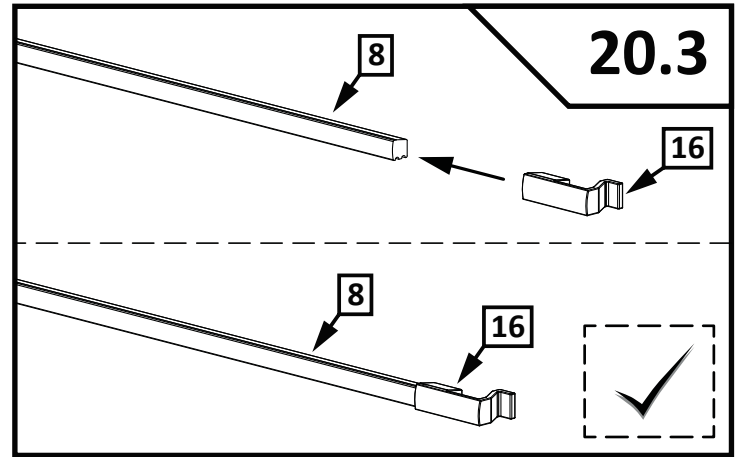
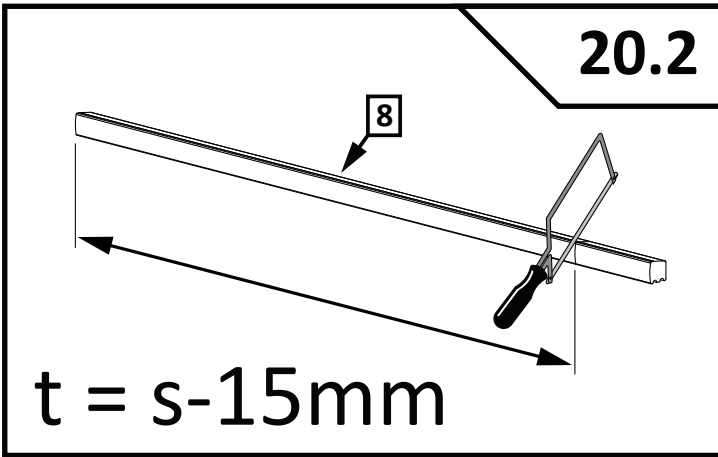

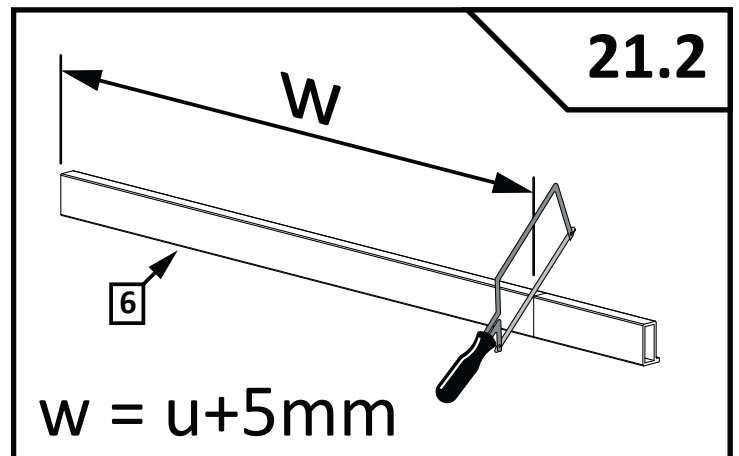
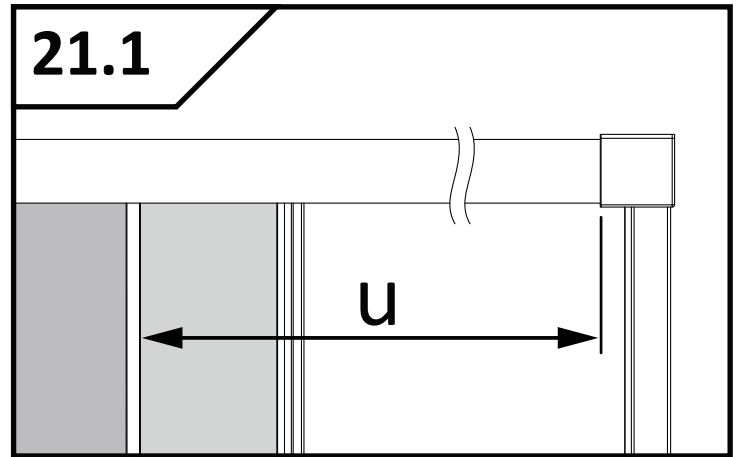
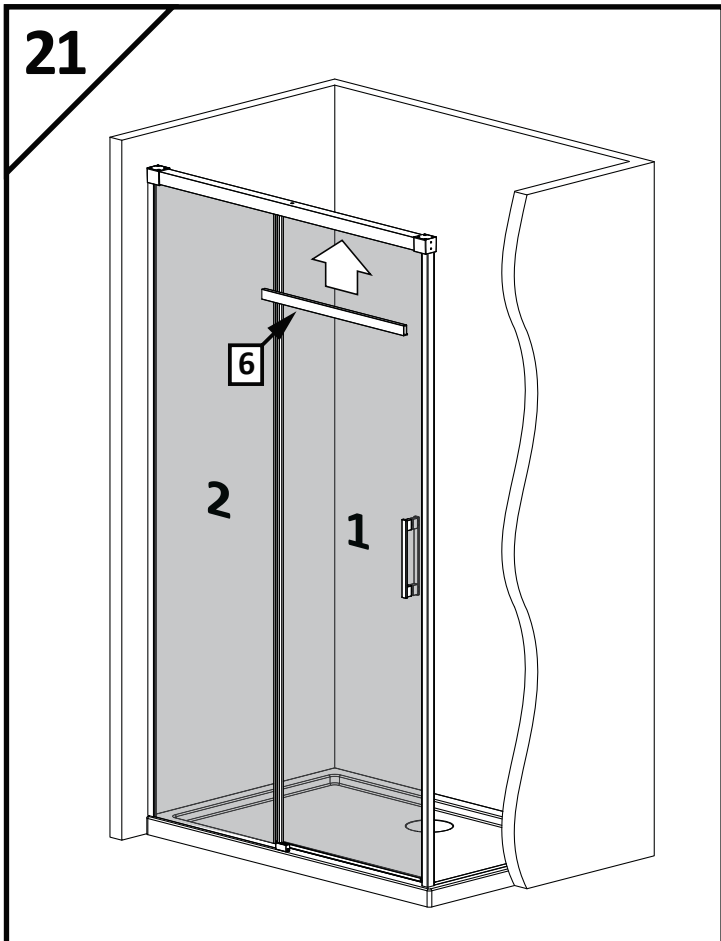
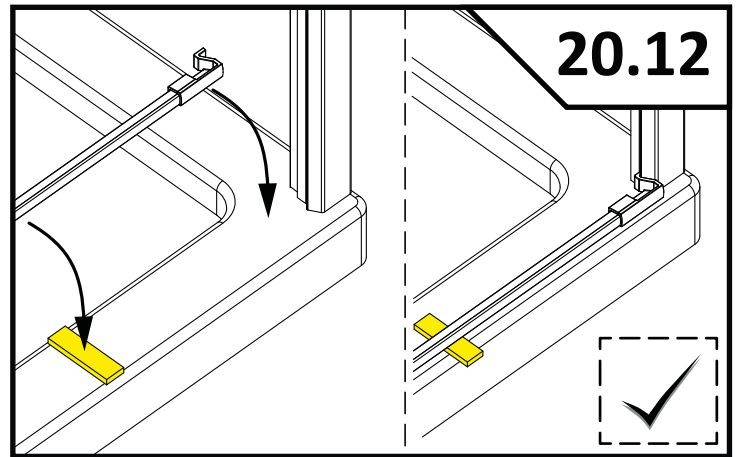
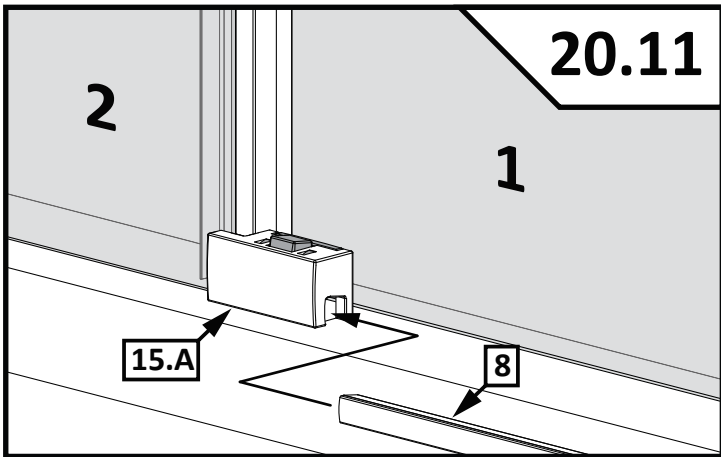
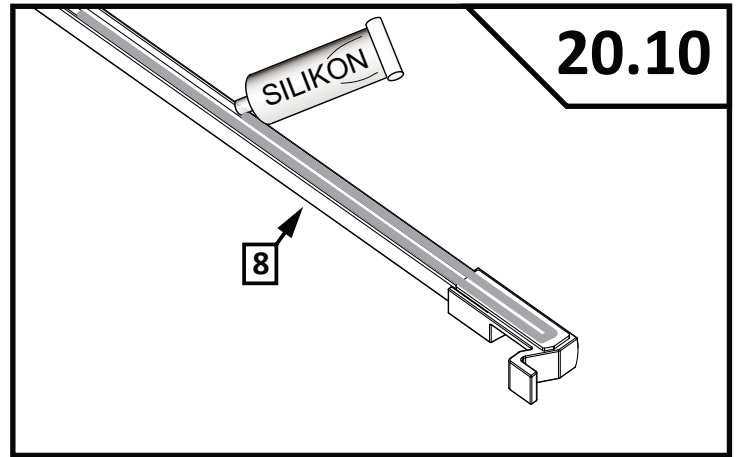
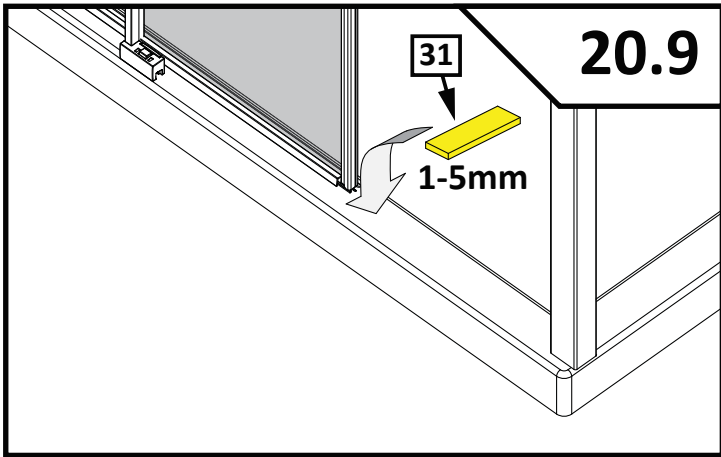

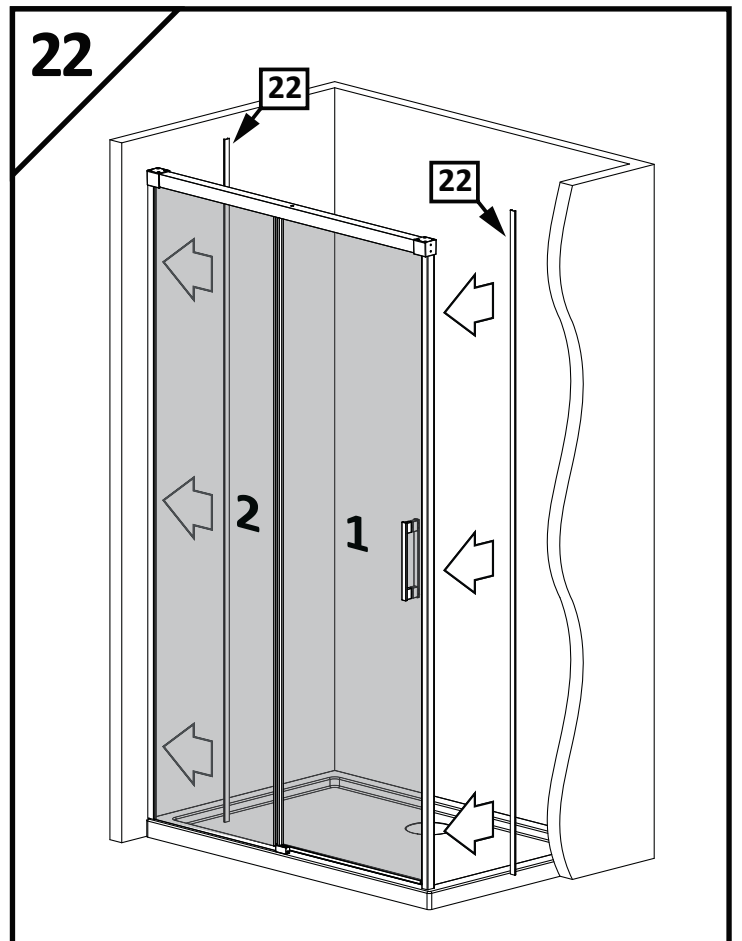
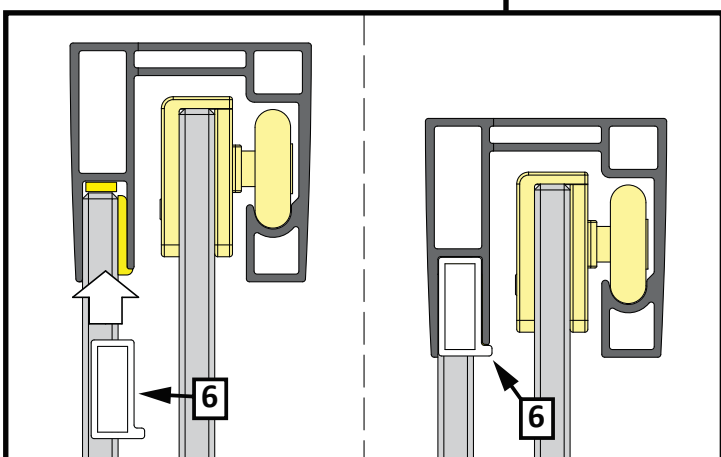
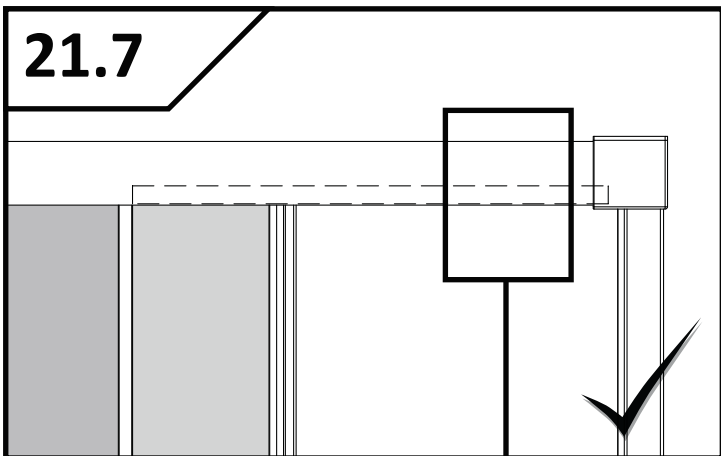
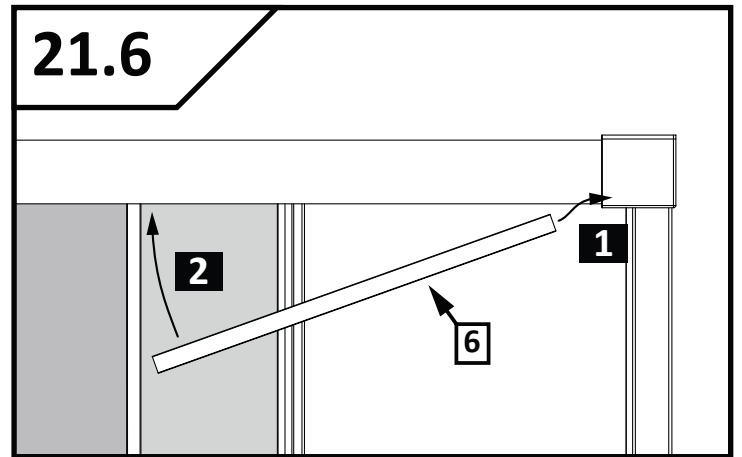
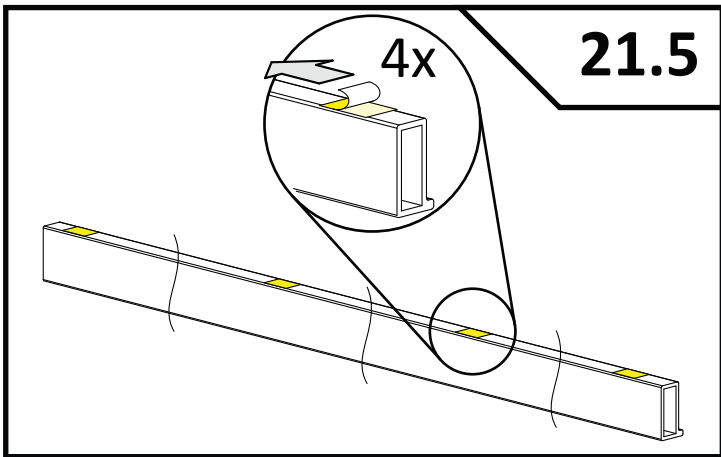
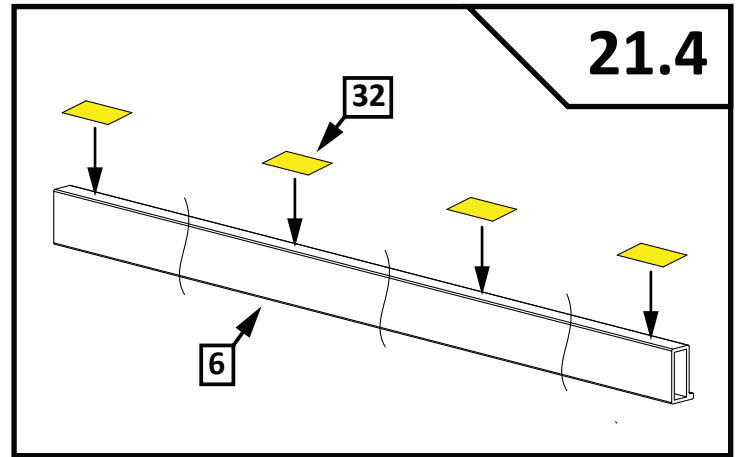
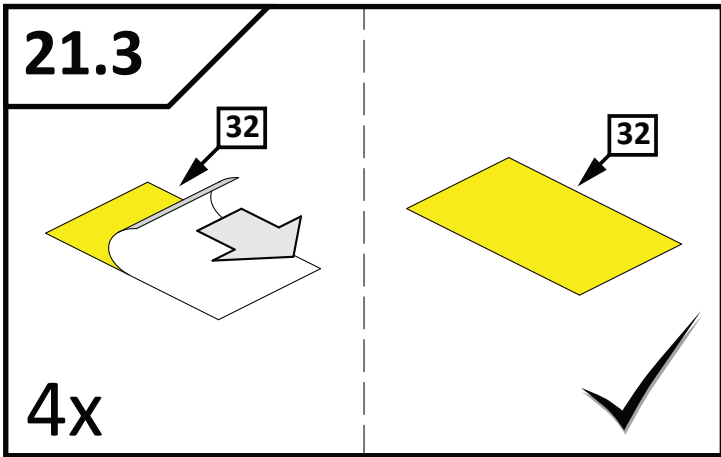

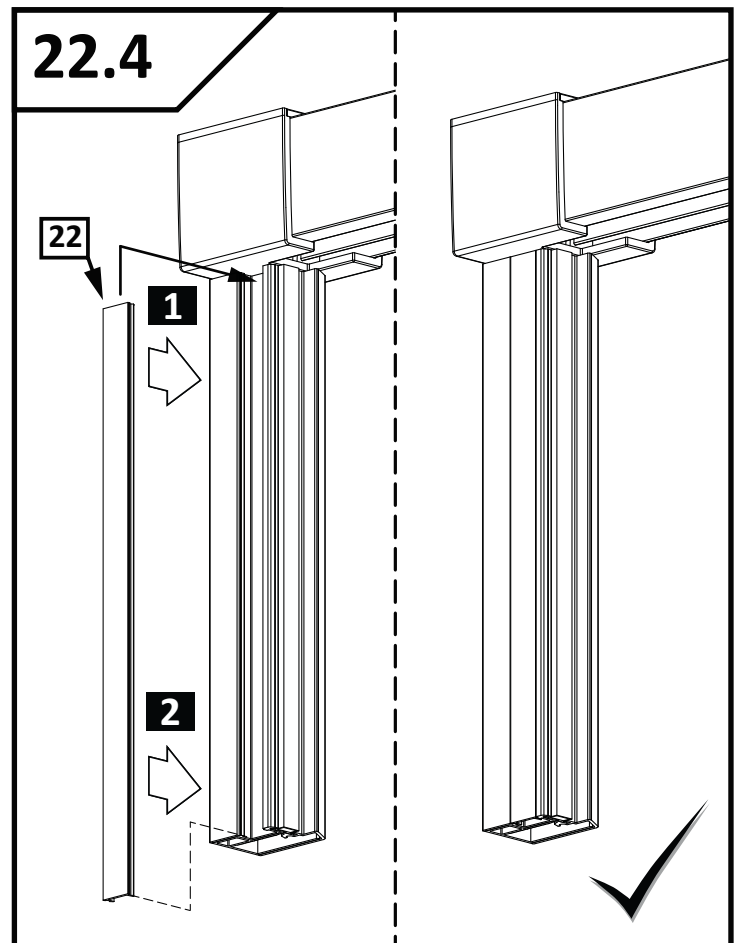
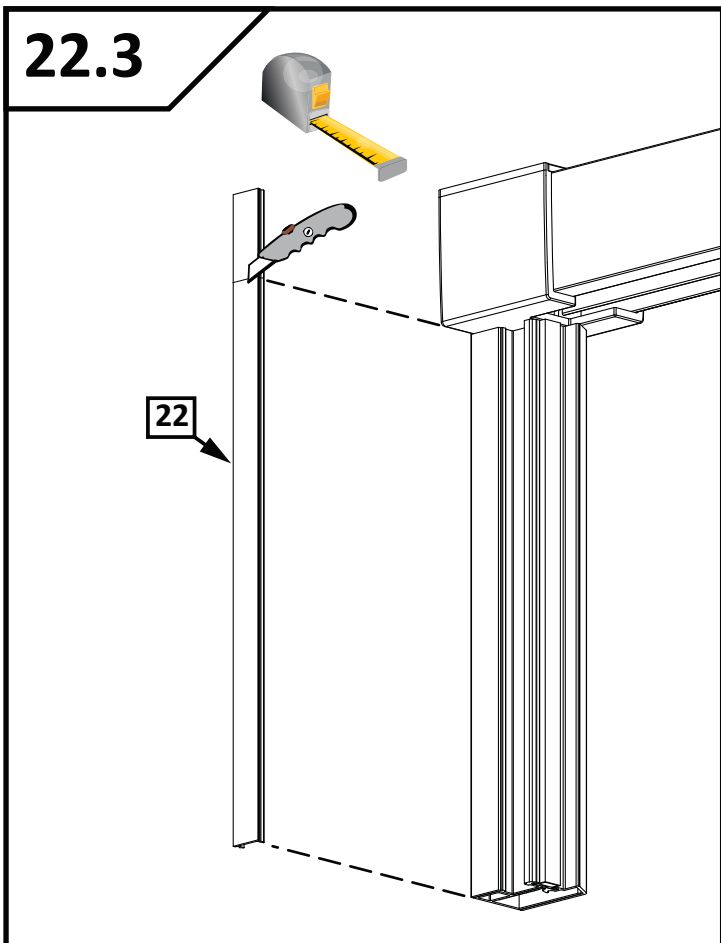
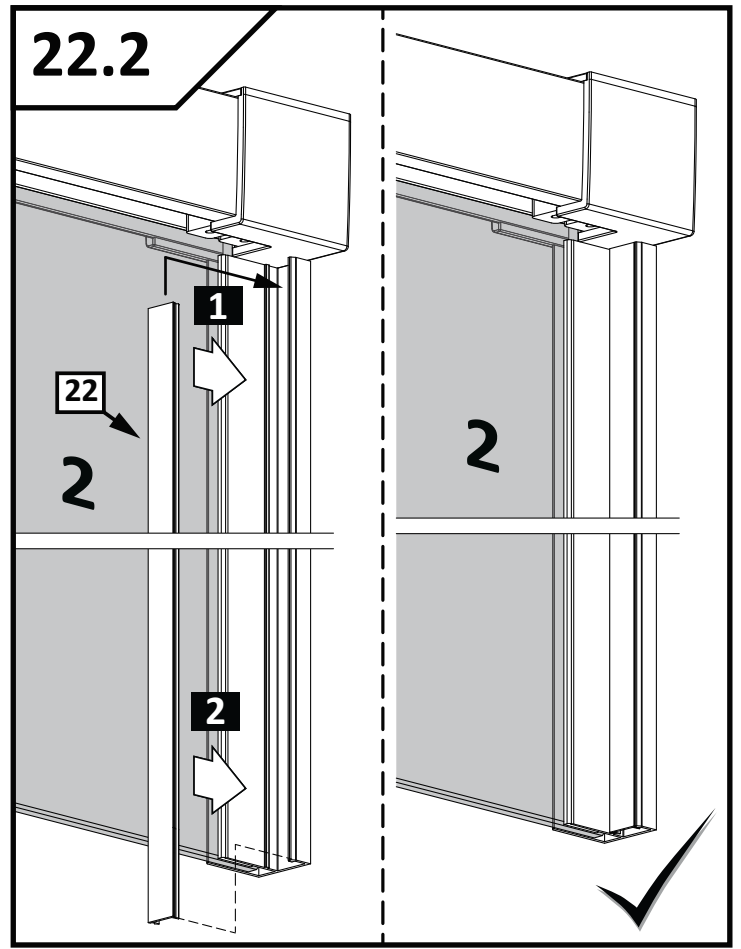
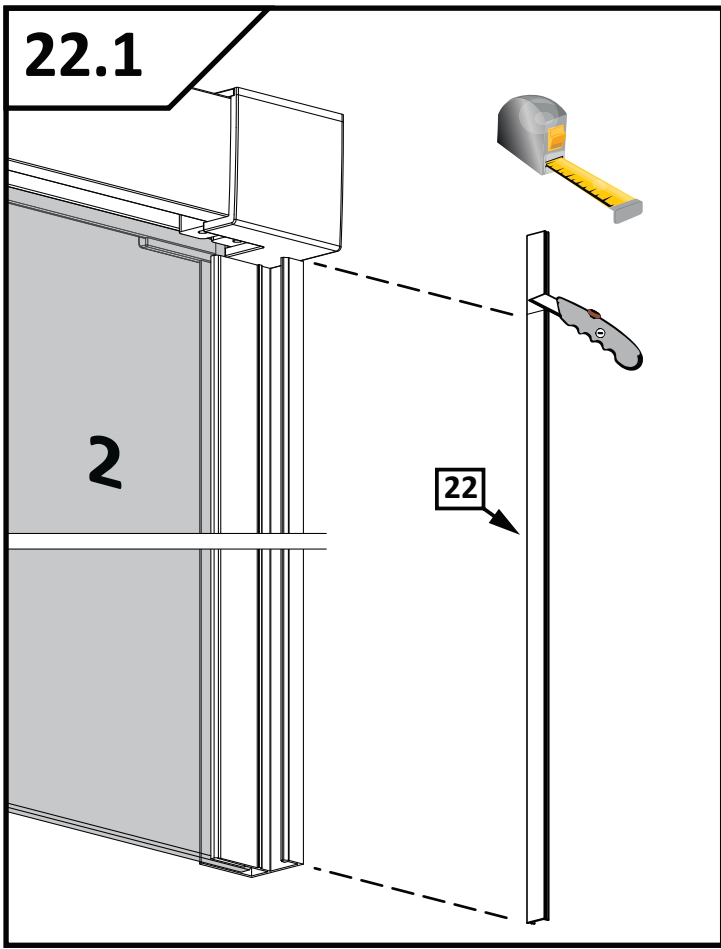

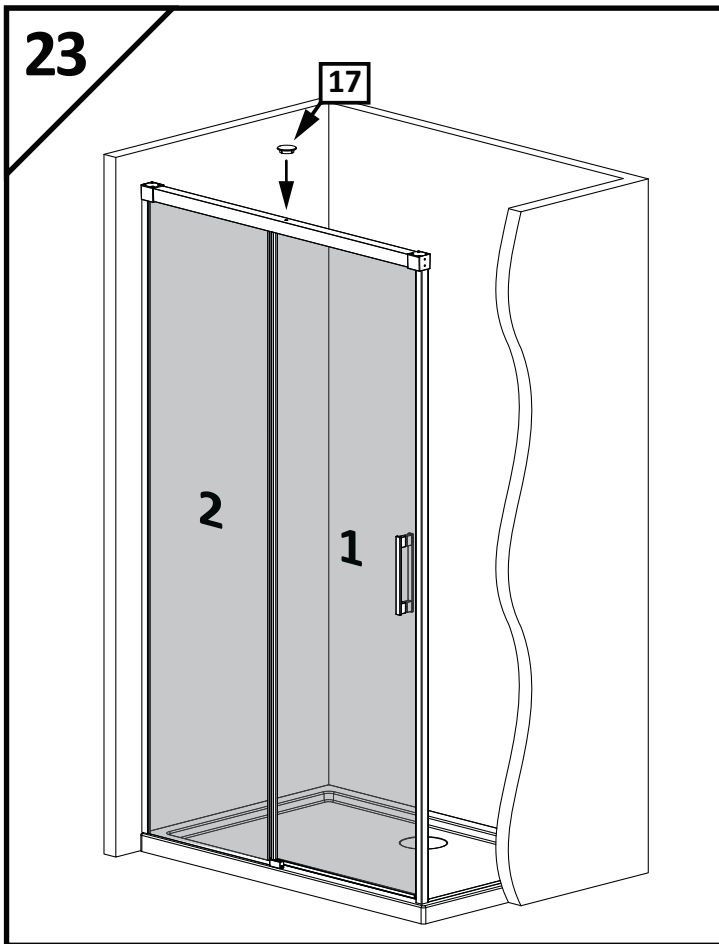



Montaż z listwą progową
Installation with threshold profile
Die Montage mit Schwalleiste
Montovanie s prahovým profilom
Instalace přechodové lišty
Монтаж с профилем порога
Szerelés küszöb profilal
Instalarea cu profil prag

 **...A**

Montaż bez listwy progowej
Installation without threshold profile
Die Montage ohne Schwalleiste
Montovanie bez prahového profilu
Instalace bez prahové lišty
Монтаж без профиля порога
Szerelés küszöb profil nélkül
Instalarea fara profil prag

 **...B**

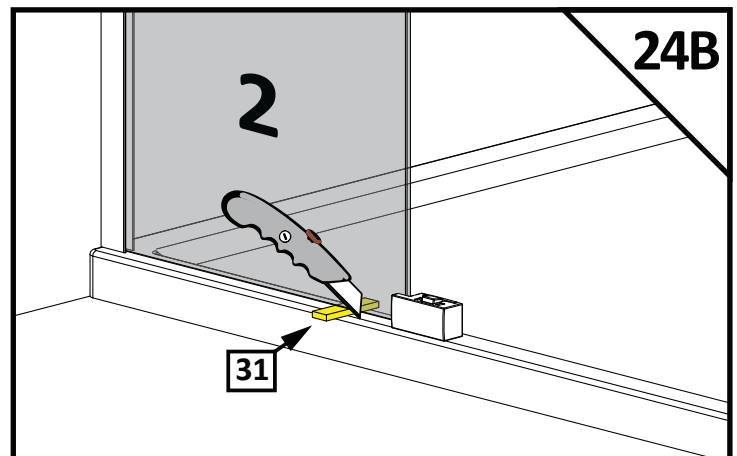
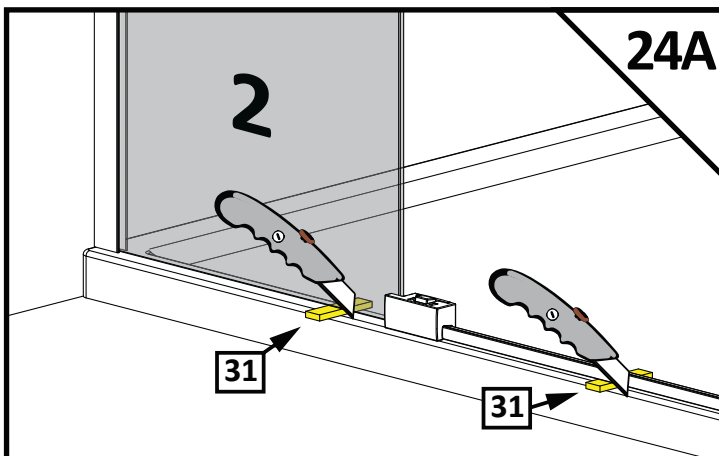

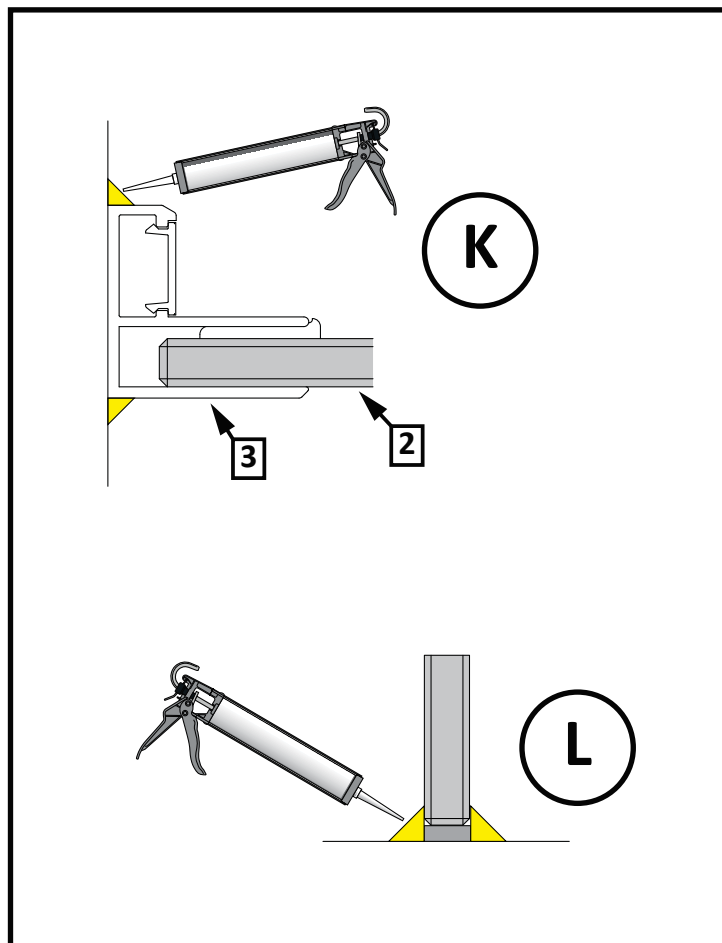
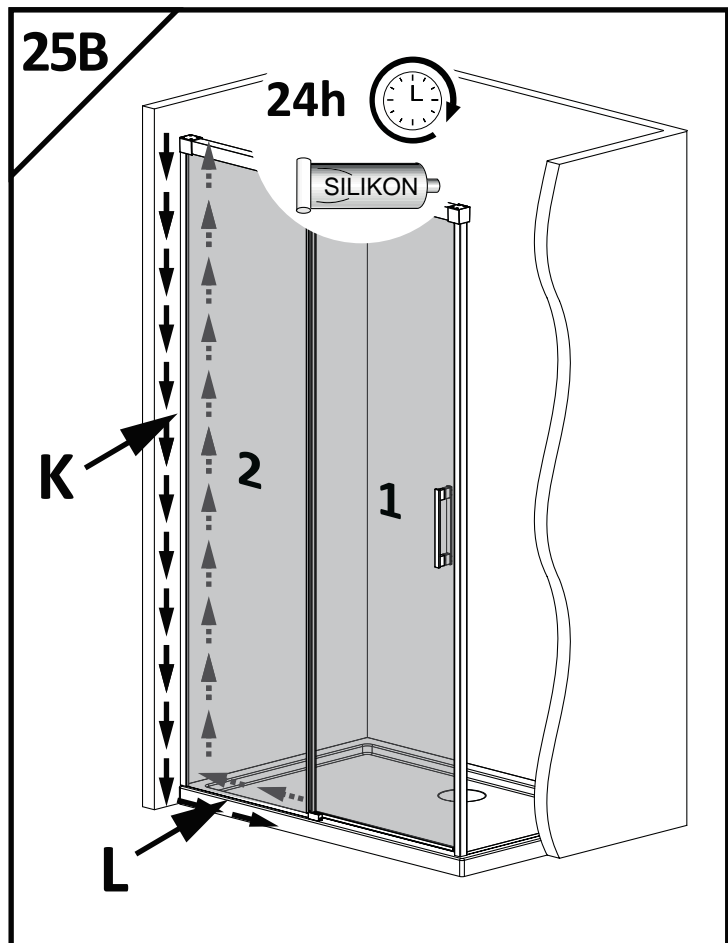
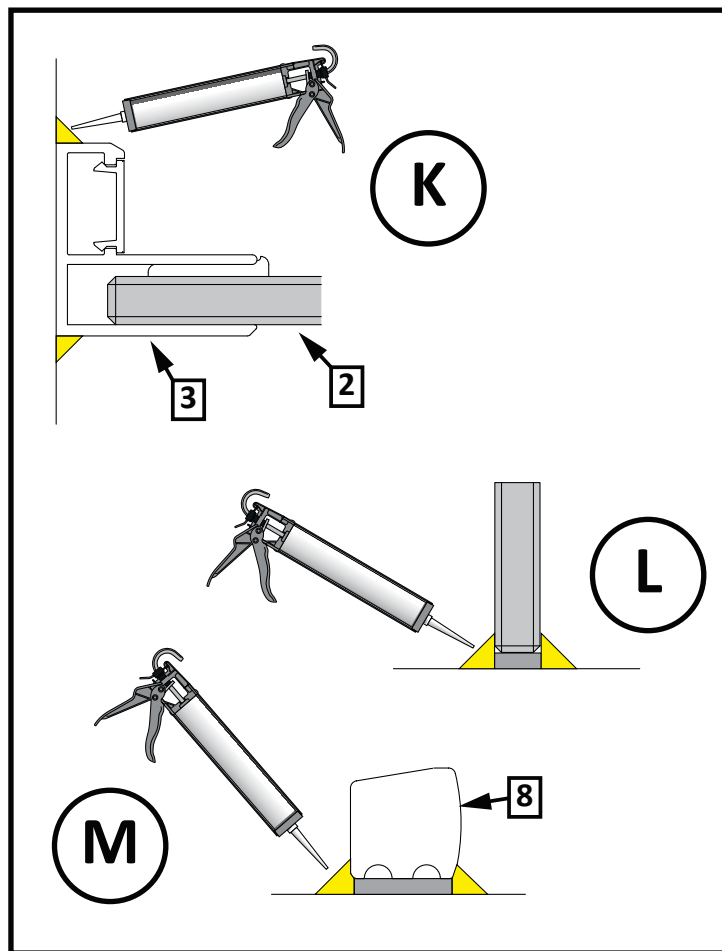
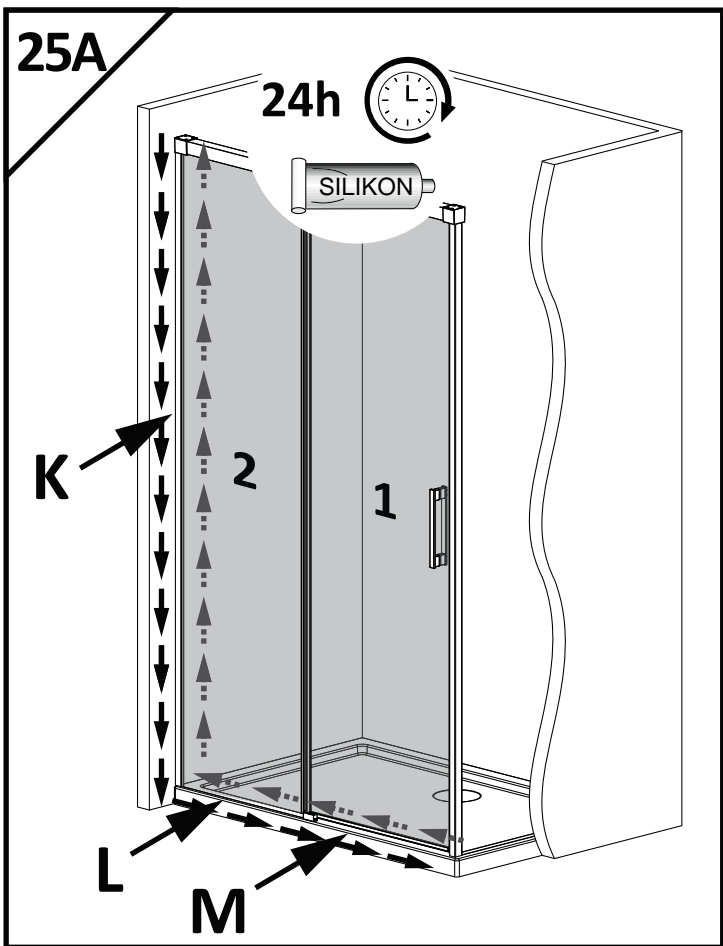

Karbantartási útmutató:



Mind az üvegfelületek, mind a műanyag elemek és az alumínium profilok tisztítására is a gyártó által javasolt tisztítószeret és vízlehúzózt célszerű használni. Ezek a **RADAWAY GLASS CLEANER** zuhanykabin tisztítószer és a **RADAWAY GLASS PROTECTOR** védőbevonat-felfrissítő készítmény.

A termék rutinszerű tisztítása

Ajánlott, hogy a kabin közvetlenül minden zuhanyzás után ki legyen tisztítva a következők szerint:

A kabin belső felületeit tiszta vízzel öblítse le, majd a vízcseppeket kézi gumilapáttal húzza le. A króm felületeket, lakkozott profilokat puha törleronggyal törölje szárazra. Mind az üvegfelületek, mind a műanyag elemek és az alumínium profilok tisztítására is a gyártó által javasolt tisztítószeret célszerű használni.

Kerülje csiszolópaszta, hígítószer, aceton, foszforsav és klórtartalmú fertőtlenítőszer alkalmazását. A használat és karbantartással kapcsolatos egyéb kérdésével forduljon a forgalmazóhoz bizalommal.

A termék alapos tisztítása, karbantartása

A tisztítás ajánlott gyakorisága: a használat mértékétől és a víz minőségétől függően hetente vagy havonta egy alkalommal. A kabin belső felületeit RADAWAY GLASS CLEANER tisztítószerrel permetezze be. Ahol vastagabb a vízkőréteg, ott puha pamut ronggyal törölje át a felületet, akár úgy is, hogy a kendőre is permetez a tisztítószerből.



Rozsdamentes acélból készült **RADAWAY VÍZLEHÚZÓ**, mely rendszeres használat esetén vízkőmentes ragyogást biztosít zuhanykabinjában. Csempe, zuhanykabin, üvegfelület és tükrök vízlehúzásához.

FIGYELEM! A Glass Cleaner tisztítószer ne hagyja 10 percnél tovább hatni! Miután áttörölte vegyszerrel a tisztítandó felületet, vízzel öblítse azt le. A vízcseppeket kézi vízlehúzóval távolítsa el. A külső felületeken is elvégezheti a tisztítást, azonban ebben az esetben ügyeljen a padlóra távozó vízmennyiségre. A króm felületeket, lakkozott profilokat puha törleronggyal törölje szárazra. Ajánlott a RADAWAY GLASS PROTECTOR vegyszerrel az üvegfelületek impregnálása. Gondoskodjon a helység megfelelő szellőzéséről a gyors száradás elősegítéséhez.

FIGYELEM! A zuhanykabinok, krómozott szerelvényeik és felületeik tisztításához csak citromsav bázisú vegyszer használata megengedett. Ecetsav, sósav, hangyasav alapú tisztítószer használata TILOS, ezek jelentős károkat okozhatnak a krómozott felületeken is. Foszfor tartalmú tisztítószer csak korlátozottan használható továbbá a különböző tisztítószer keverése szintén nem megengedett.