

⚠ BIZTONSÁGI UTASÍTÁSOK

- ⚠ A szerelésnél a zúzódások és vágási sérülések elkerülése érdekében kesztyűt kell viselni.
- ⚠ A terméket csak fürdéshez, mosakodáshoz, és egészségügyi tisztálkodáshoz szabad használni.
- ⚠ A hidegvíz- és a melegvíz-csatlakozások közötti nagy nyomáskülönbséget kikell egyenlíteni!

SZERELÉSI UTASÍTÁSOK

- / A szerelés előtt ellenőrizni kell, hogy a terméknek nincs-e szállítási sérülése. Beépítés után a szállítási- vagy felületi sérüléseket nem ismerik el.
- / A vezetékeket és a csaptelepet az érvényes szabványoknak megfelelően kell felszerelni, öblíteni és ellenőrizni
- / Az egyes országokban érvényes installációs irányelveket be kell tartani.

MŰSZAKI ADATOK

Üzemi nyomás:	max. 1 MPa
Ajánlott üzemi nyomás:	0,1 - 0,5 MPa
Nyomáspróba:	1,6 MPa
	(1 MPa = 10 bar = 147 PSI)
Forróvíz hőmérséklet:	max. 70°C
Forróvíz javasolt hőmérséklete:	65°C
Termikus fertőtlenítés:	max. 70°C/4 perc

A terméket kizárólag ivóvízhez tervezték!

SZIMBÓLUMOK LEÍRÁSA



Ne használjon ecetsavtartalmú szilikon!



BEÁLLÍTÁS (lásd a oldalon 34)
A meleg víz korlátozás beállítása. Átfolyós vízmelegítőknél meleg víz korlátozó használata nem ajánlott.



MÉRETET (lásd a oldalon 31)



ÁTFOLYÁSI DIAGRAMM
(lásd a oldalon 31)
szabad átfolyás

- ① Zuhany lefolyója
- ② Kád lefolyója



HASZNÁLAT (lásd a oldalon 35)



TISZTÍTÁS (lásd a oldalon 38)



TARTOZÉKOK
(lásd a oldalon 36)

- XXX = Színkódolás
- 000 = króm
- 340 = Brushed Black Chrome
- 800 = acéloptika



VIZSGAJEL (lásd a oldalon 39)

HIBA	OK	MEGOLDÁS
/ Nehezen nyitható a csap.	/ A kerámiabetét meghibásodott, elvizesedett.	/ A kerámiabetétet ki kell cserélni.
/ Csöpög a csap.	/ A kerámiabetét meghibásodott.	/ A kerámiabetétet ki kell cserélni.
/ Túl alacsony melegvíz hőmérséklet, nincs hidegvíz. A hidegvíz kiválasztásakor beindul az átfolyós melegítő.	/ A melegvíz szabályozó rosszul van beállítva. / Keresztfolyás	/ A melegvíz szabályozót újra be kell állítani. / A kerámiabetétet ki kell cserélni.
/ Az átállítás nem működik	/ Lerakódások / Túl kicsi víznyomás / A kódváltó szelep hibás	/ Váltószelepet tisztítani/O-gyűrűket zsiszolni / Növelje a víznyomást / Az átállító cseréje

SZERELÉS (lásd a oldalon 32)



△ TURVALLISUUSOHJEET

- △ Asennuksessa on käytettävä käsiineitä puristumien ja viiltojen aiheuttamien tapaturmien estämiseksi.
- △ Tuotetta saa käyttää ainoastaan kylpy-, hygienia- ja puhdistustarkoituksiin.
- △ Suuret paine-erot kylmä- ja kuumavesiliitäntöjen välillä on tasattava.

ASENNUSOHJEET

- / Ennen asennusta on tarkastettava tuotteen mahdolliset kuljetusvahingot. Asennuksen jälkeen kuljetus- ja pintavaurioita ei hyväksytä.
- / Putket ja hana on asennettava, huuhdeltava ja tarkastettava voimassa olevien standardien mukaisesti.
- / Jokaisessa maassa on noudatettava siellä päteviä asennusohjeita.

TEKNISET TIEDOT

Käyttöpaine:	maks. 1 MPa
Suosittelut käyttöpaine:	0,1 - 0,5 MPa
Koestuspaine:	1,6 MPa
	(1 MPa = 10 bar = 147 PSI)
Kuuman veden lämpötila:	maks. 70°C
Kuuman veden suosituslämpötila:	65°C
Lämpödesinfektio:	maks. 70°C / 4 min

Tuote on suunniteltu käytettäväksi ainoastaan juomaveden kanssa!

MERKIN KUVAUS



Älä käytä etikkahappopitoista silikonia!



S Ä Ä T Ö (katso sivu 34)

Lämpötilan rajoittimen säätäminen. Emme suosittele käyttämään lämpötilan rajoitinta vedenlämmittimen (läpivirtauskuumennin) yhteydessä.



MITAT (katso sivu 31)



VIRTAUSDIAGRAMMI

(katso sivu 31)

vapaa läpivirtaus

① Suihkun lähti

② Ammeen lähti



KÄYTTÖ (katso sivu 35)



PUHDISTUS (katso sivu 38)



VARAOSAT

(katso sivu 36)

XXX = Värikoodaus

000 = kromi

340 = Brushed Black Chrome

800 = inox-optinen



KOESTUSMERKKI (katso sivu 39)

HÄIRIÖ	SYY	TOIMENPIDE
/ Hana on raskaskäyttöinen	/ Patruuna rikki, kalkkikerrostumia	/ Vaihda patruuna
/ Hanasta tippuu vettä	/ Patruuna rikki	/ Vaihda patruuna
/ Lämminveden lämpötila liian alhainen, ei kylmää vettä. Läpivirtauskuumennin käynnistyy kylmää vettä otettaessa.	/ Lämminveden rajoitin väärin säädetty	/ Säädä lämminveden rajoitin
/ Valitsin ei toimi	/ Ristiinvirtaus	/ Vaihda patruuna
	/ kerrostumia	/ Vaihden puhdistus/O-renkaiden rasvaus
	/ Liian matala vedenpaine	/ lisää vedenpainetta
	/ Valitsin rikki	/ Vaihda valitsin

ASENNUS (katso sivu 32) 

△ SÄKERHETSANVISNINGAR

- △ Handskar ska bäras under monteringsarbetet så att man kan undvika kläm- och skärskadorgen werden.
- △ Produkten får bara användas till kroppshygien med bad och dusch.
- △ Stora tryckskillnader mellan anslutningarna för varmt och kallt vatten måste utjämnas.

MONTERINGSANVISNINGAR

- / Det måste undersökas om produkten har transportskadorna innan den monteras. Efter monteringen accepteras inga transport- eller ytskiktskador.
- / Ledningarna och blandaren måste monteras, spolas igenom och kontrolleras enligt de gällande normerna.
- / De installationsriktlinjer som gäller i länderna ska följas.

TEKNISKA DATA

Driftstryck:	max. 1 MPa
Rek. driftstryck:	0,1 - 0,5 MPa
Tryck vid provtryckning:	1,6 MPa (1 MPa = 10 bar = 147 PSI)
Varmvattentemperatur:	max. 70°C
Rek. varmvattentemp.:	65°C
Termisk desinfektion:	max. 70°C/4 min

Produkten är enbart avsedd för dricksvatten!

SYMBOLFÖRKLARING



Använd inte silikon som innehåller ättiksyra!



JUSTERING (se sidan 34)
Ställa in varmvattenregleringen. Tillsammans med varmvattenberedare rekommenderas inte en varmvattenspärr.



MÅTTEN (se sidan 31)



FLÖDESSCHEMA
(se sidan 31)
fri genomströmning

- ① Avlopp dusch
- ② Avlopp kar



HANTERING (se sidan 35)



RENGÖRING (se sidan 38)



RESERVDLAR
(se sidan 36)

- XXX = Färgkodning
- 000 = krom
- 340 = Brushed Black Chrome
- 800 = rostfri-optik



TESTSIGILL (se sidan 39)

STÖRNING	ORSAK	ÅTGÄRD
/ Blandare är trög	/ Patron defekt, förkalkad	/ Byt ut patron
/ Blandare droppar	/ Patron defekt	/ Byt ut patron
/ För låg varmvattentemperatur, inget kallvatten. Varmvattenberedaren slår på när kallvatten väljs.	/ Varmvattenreglering felaktigt inställd / Korsflöde	/ Ställ in varmvattenreglering / Byt ut patron
/ Omkopplare fungerar inte	/ Avlagringar / För lågt vattentryck / Omkopplare defekt	/ Rengör omkastare/smörj O-ringar / Öka vattentrycket / Byt ut omkopplare

MONTERING (se sidan 32) 

SAUGUMO TECHNIKOS NURODYMAI

- ⚠ Apsaugai nuo užspaudimo ir įsijovimo montavimo metu mūvėkite pirštines.
- ⚠ Gaminyi turi būti naudojamas tik maudymuisi, kūno higienai ir švarai palaikyti.
- ⚠ Turi būti išlyginti šalto ir karšto slėgio nelygumai.

MONTAVIMO INSTRUKCIJA

- / Prieš montuojant būtina patikrinti, ar gaminyi nebuvo pažeistas transportavimo metu. Sumontavus pretenzijos dėl transportavimo ir paviršiaus pažeidimų nepriimamos.
- / Vamzdžiai ir sujungimai turi būti montuojami, plaunami ir tikrinami pagal galiojančias normas.
- / Laikykis atitinkamoje šalyje galiojančių direktyvų dėl įrengimo.

TECHNINIAI DUOMENYS

Darbinis slėgis: ne daugiau kaip 1 MPa
 Rekomenduojamas slėgis: 0,1 - 0,5 MPa
 Bandomasis slėgis: 1,6 MPa
 (1 MPa = 10 barų = 147 PSI)
 Karšto vandens temperatūra: ne daugiau kaip 70°C
 Rekomenduojama karšto vandens temperatūra: 65°C
 Terminis dezinfekavimas: ne daugiau kaip 70°C/4 min

Produktas skirtas tik geriamajam vandeniui!

SIMBOLIO APRAŠYMAS



Nenaudokite silikono, kurio sudėtyje yra acto rūgšties!



REGULIAVIMAS (žr. psl. 34)
 Karšto vandens ribojimas. Kartu su cirkuliaciniais šildytuvais nerekomenduojama naudoti karšto vandens blokavimo įtaisų.



IŠMATAVIMAI (žr. psl. 31)



PRALAUDUMO DIAGRAMA
 (žr. psl. 31)

laisvas vandens pralaidumas

- ① Dušo išleidimas
- ② Vonios išleidimas



EKSPLOATACIJA (žr. psl. 35)



VALYMAS (žr. psl. 38)



ATSARGINĖS DALYS
 (žr. psl. 36)

XXX = Spalvos
 000 = chrom
 340 = Brushed Black Chrome
 800 = plienas



BANDYMO PAŽYMA (žr. psl. 39)

GEDIMAS	PRIEŽASTIS	PRIEMONĖ
/ Sunkiai sukiojama rankenėlė	/ Kasetė pažeista, užkalkėjusi	/ Pakeisti kasetę
/ Maišytuvas praleidžia vandenį	/ Kasetė pažeista	/ Pakeisti kasetę
/ Per maža karšto vandens temperatūra, nėra šalto vandens. Momentinis pašildytojas pradeda veikti, kai naudojamas šalta vanduo	/ Neteisingai nustatytas karšto vandens ribotuvas / Kryžminė srovė	/ Nustatyti karšto vandens ribotuvą / Pakeisti kasetę
/ Perjungėjas nefunkcionuoja	/ Apnašos / Nepakankamas vandens spaudimas / Pažeistas perjungėjas	/ Išvalykite atsukimą/sutepkite O-žiedus / Pakelti vandens spaudimą / Pakeisti perjungėją

MONTAVIMAS (žr. psl. 32) 

△ SIGURNOSNE UPUTE

- △ Prilikom montaže se radi sprječavanja prignječenja i posjekotina moraju nositi rukavice.
- △ Proizvod se smije primjenjivati samo za kupanje, tuširanje i osobnu higijenu.
- △ Velika razlika u pritisku između vruće i hladne vode mora biti izbalansirana.

UPUTE ZA MONTAŽU





- / Prije montaže mora se provjeriti je li proizvod oštećen prilikom transporta. Nakon ugradnje se ne priznaju nikakve reklamacije koje se odnose na površinska i transportna oštećenja.
- / Cijevi i armatura moraju biti postavljeni, isprani i testirani prema važećim normama.
- / Obvezno se moraju uvažiti propisi o instalacijama koji vrijede u dotičnoj zemlji.

TEHNIČKI PODATCI

Najveći dopušteni tlak:	tlak 1 MPa
Preporučeni tlak:	0,1 - 0,5 MPa
Probni tlak:	1,6 MPa
	(1 MPa = 10 bar = 147 PSI)
Temperatura vruće vode:	tlak 70°C
Preporučena temperatura vruće vode:	65°C
Termička dezinfekcija:	tlak 70°C/4 min

Proizvod je koncipiran isključivo za pitku vodu!

OPIS SIMBOLA

-  Nemojte koristiti silikon koji sadrži octenu kiselinu!
-  **REGULACIJA** (pogledaj stranicu 34)
Namještanje limitera tople vode. U kombinaciji s protočnim bojlerima nije preporučljiva primjena sustava za blokiranje dotoka tople vode.
-  **MJERE** (pogledaj stranicu 31)
-  **DIJAGRAM PROTOKA** (pogledaj stranicu 31)
slobodan protok
① Ogranak tuš
② Ogranak kada
-  **UPOTREBA** (pogledaj stranicu 35)
-  **ČIŠĆENJE** (pogledaj stranicu 38)
-  **REZERVNI DJELOVI** (pogledaj stranicu 36)
XXX = Boje
000 = krom
340 = Brushed Black Chrome
800 = plemeniti čelik
-  **OZNAKA TESTIRANJA** (pogledaj stranicu 39)

GREŠKA	UZROK	OTKLANJANJE
/ Ručica se zaglavila	/ Neispravan uložak Taloženje kamenca	/ Zamijenite uložak
/ Slavina kaplje	/ Neispravan uložak	/ Zamijenite uložak
/ Preniska temperatura vruće vode, nedostatak hladne vode. Protočni bojler se pali pri podešenoj funkciji za protok hladne vode	/ limiter vruće vode nije dobro podešen / Križni tok vode	/ Podesite limiter vruće vode / Zamijenite uložak
/ Selektor ne radi	/ Naslage / Prenizak tlak vode / Selektor je neispravan	/ Čišćenje selektora i podmazivanje O-prstenova / Povećajte tlak vode / Zamijenite selektor

SASTAVLJANJE (pogledaj stranicu 32) 

Δ GÜVENLİK UYARILARI

- Δ Montaj esnasında ezilme ve kesilme gibi yaralanmaları önlemek için eldiven kullanılmalıdır.
- Δ Ürün yalnızca banyo, hijyen ve beden temizliği amaçları doğrultusunda kullanılabilir.
- Δ Sıcak ve soğuk su bağlantıları arasında büyük basınç farklılıkları varsa, bu basınç farklılıklarının dengelenmesi gerekir.

MONTAJ AÇIKLAMALARI

- / Montaj işleminden önce ürün nakliye hasarları yönünden kontrol edilmelidir. Montaj işleminden sonra nakliye veya yüzey hasarları için sorumluluk üstlenilmemektedir.
- / Boruların ve armatürün montajı, yıkanması ve kontrolü geçerli normlara göre yapılmalıdır.
- / Ülkelerde geçerli kurulum yönetmeliklerine riayet edilmelidir.

TEKNİK BİLGİLER

İşletme basıncı:	azami 1 MPa
Tavsiye edilen işletme basıncı:	0,1 - 0,5 MPa
Kontrol basıncı:	1,6 MPa
	(1 MPa = 10 bar = 147 PSI)
Sıcak su sıcaklığı:	azami 70°C
Tavsiye edilen su ısı:	65°C
Termik dezenfeksiyon:	azami 70°C/4 dak

Ürün sadece şebeke suyu için tasarlanmıştır!

SİMGE AÇIKLAMASI

Asetik asit içeren silikon kullanmayın!



AYARLAMA (bakınız sayfa 34)
Sıcak su sınırlamasının ayarlanması. Sıcak su kilitinin sürekli ısıtıcıyla kullanılması tavsiye edilmez.



ÖLÇÜLERİ (bakınız sayfa 31)



AKIŞ DİYAGRAMI
(bakınız sayfa 31)
serbest akış

- ① Su püskürtücü çıkışı
- ② Tekne çıkışı



KULLANIMI (bakınız sayfa 35)



TEMİZLEME (bakınız sayfa 38)



YEDEK PARÇALAR
(bakınız sayfa 36)

- XXX = Renkler
- 000 = krom
- 340 = Brushed Black Chrome
- 800 = paslanmaz çelik - optik



KONTROL İŞARETİ
(bakınız sayfa 39)

ARIZA	SEBEP	YARDIM
/ Batarya kullanımı ağırlaşiyor	/ Kartuş Bozulmuş ve kireçlenmiş olabilir	/ Kartuşu değiştirin
/ Batarya su damlatıyor	/ Kartuş bozuk olabilir	/ Kartuşu değiştirin
/ Sıcak su sıcaklığı çok düşük, soğuk su yok. Soğuk su seçilince şofben çalışmaya başlıyor.	/ Isı limitleyici düzgün çalışmıyor	/ Isı limitleyiciyi yeniden ayarlayın
/ Divertör çalışmıyor	/ Çökelmeler	/ Dönüştürücüyü temizleme/O ringleri yağlama
	/ Su basıncı düşük	/ Su basıncını artırın
	/ Divertör arızalı	/ Divertörü değiştirin

MONTAJI (bakınız sayfa 32) 

⚠ INSTRUCȚIUNI DE SIGURANȚĂ

- ⚠ La montare utilizați mănuși pentru evitarea contuziunilor și tăierii mâinilor.
- ⚠ Produsul poate fi utilizat doar pentru spălarea, menținerea igienei și curățarea corpului.
- ⚠ Diferențele de presiune mari între alimentarea cu apă rece și apă caldă trebuie echilibrate.

DESCRIEREA SIMBOLURILOR

Nu utilizați silicon cu conținut de acid acetic!



REGLARE (vezi pag. 34)
Reglarea limitatorului de apă caldă. Nu se recomandă folosirea unui limitator de apă caldă în combinație cu un boiler instant.

INSTRUCȚIUNI DE MONTARE

- / Înainte de instalare verificați, dacă produsul prezintă deteriorări de transport. După instalare garanția nu acoperă deteriorările de transport și cele de suprafață.
- / Conductele și bateriile trebuie montate, spălate și verificate conform normelor în vigoare.
- / Respectați reglementările referitoare la instalare valabile în țara respectivă.

**DIMENSIUNI** (vezi pag. 31)

DIAGRAMA DE DEBIT
(vezi pag. 31)
debit cu curgere liberă

- ① Orificiu de scurgere duș
- ② Orificiu de scurgere vană

DATE TEHNICE

Presiune de funcționare: max. 1 MPa
 Presiune de funcționare recomandată: 0,1 - 0,5 MPa
 Presiune de verificare: 1,6 MPa
 (1 MPa = 10 bar = 147 PSI)
 Temperatura apei calde: max. 70°C
 Temperatura recomandată a apei calde: 65°C
 Dezinfecție termică: max. 70°C/4 min

**UTILIZARE** (vezi pag. 35)**CURĂȚARE** (vezi pag. 38)

PIESE DE SCHIMB
(vezi pag. 36)

XXX = Coduri de culori
 000 = crom
 340 = Brushed Black Chrome
 800 = otel inox



CERTIFICAT DE TESTARE
(vezi pag. 39)

Produsul este destinat exclusiv pentru apă potabilă.

DERANJAMENT	CAUZA	MĂSURI DE REMEDIERE
/ Bateria se mișcă dificil	/ Cartuș defect din cauza depunerilor de calcar	/ Schimbați cartușul.
/ Bateria picură	/ Cartuș defect	/ Schimbați cartușul.
/ Temperatura apei este prea mică, nu este apă rece. Boilerul instant pornește când se dă drumul la apa rece	/ Limitarea temperaturii apei calde setată incorect.	/ Setați limitarea temperaturii apei calde.
	/ Curgere încrucișată (apa rece în intră în conducta de apă caldă și invers)	/ Schimbați cartușul.
/ Cartușul nu funcționează.	/ Depuneri	/ Curățați inversorul/ungeți inelele O
	/ Presiune apă prea mică	/ Măriți presiunea de apă
	/ Cartuș defect	/ Schimbați cartușul.

MONTARE (vezi pag. 32)

Δ ΥΠΟΔΕΙΞΕΙΣ ΑΣΦΑΛΕΙΑΣ

- Δ Για να αποφύγετε τραυματισμούς κατά τη συναρμολόγησή πρέπει να φοράτε γάντια.
- Δ Το προϊόν επιτρέπεται να χρησιμοποιείται μόνο σαν μέσο λουτρού υγιεινής και καθαρισμού του σώματος.
- Δ Οι διαφορές της πίεσης μεταξύ της σύνδεσης κρύου και ζεστού νερού θα πρέπει να αντιστοιχίζονται.

ΟΔΗΓΙΕΣ ΣΥΝΑΡΜΟΛΟΓΗΣΗΣ







- / Πριν τη συναρμολόγηση πρέπει να εξεταστεί το προϊόν για ζημιές μεταφοράς. Μετά την εγκατάσταση δεν αναγνωρίζονται ζημιές από τη μεταφορά ή επιφανειακές ζημιές.
- / Οι σωλήνες και η μπαταρία πρέπει να τοποθετηθούν σύμφωνα με τα ισχύοντα πρότυπα, να τοθούν υπό πίεση και να δοκιμαστούν.
- / Θα πρέπει να τηρούνται οι οδηγίες εγκατάστασης που ισχύουν σε κάθε κράτος.

ΤΕΧΝΙΚΑ ΧΑΡΑΚΤΗΡΙΣΤΙΚΑ

Λειτουργία πίεσης: **έως 1 MPa**
 Συνιστώμενη λειτουργία πίεσης: **0,1 - 0,5 MPa**
 Πίεση ελέγχου: **1,6 MPa**
 (1 MPa = 10 bar = 147 PSI)
 Θερμοκρασία ζεστού νερού: **έως 70°C**
 Συνιστώμενη θερμοκρασία ζεστού νερού: **65°C**
 Εμρμική απολύμανση: **έως 70°C / 4 min**

Το προϊόν έχει σχεδιαστεί αποκλειστικά για πόσιμο νερό!

ΠΕΡΙΓΡΑΦΗ ΣΥΜΒΟΛΩΝ

-  Μην χρησιμοποιείτε σπλικόνη που περιέχει οξικό οξύ!
-  ΡΥΘΜΙΣΗ (βλ. Σελίδα 34)
Ρύθμιση του δοσομετρητή ζεστού νερού. Δεν συνιστάται η διάταξη φραγής ζεστού νερού σε συνδυασμό με ταχυθερμοσίφωνα.
-  ΔΙΑΣΤΑΣΕΙΣ (βλ. Σελίδα 31)
-  ΔΙΑΓΡΑΜΜΑ ΡΟΗΣ (βλ. Σελίδα 31)
Ελεύθερη ροή
① Έξοδος ντους
② Έξοδος μπανιέρας
-  ΧΕΙΡΙΣΜΟΣ (βλ. Σελίδα 35)
-  ΚΑΘΑΡΙΣΜΟΣ (βλ. Σελίδα 38)
-  ΑΝΤΑΛΛΑΚΤΙΚΑ (βλ. Σελίδα 36)
XXX = Χρώμα
000 = Επιχρωμιωμένο
340 = Brushed Black Chrome
800 = οπτική ανοξείδωτο χάλυβα
-  ΣΗΜΑ ΕΛΕΓΧΟΥ (βλ. Σελίδα 39)

ΒΛΑΒΗ	ΑΙΤΙΑ	ΔΙΟΡΘΩΣΗ
/ Σκληρή μπαταρία (μείκτης)	/ Ελαττωσικό φασίγγιο, άλατο	/ Αλλαγή φασίγγιου
/ Η μπαταρία σπάει	/ Ελαττωσικό φασίγγιο	/ Αλλαγή φασίγγιου
/ Χαμηλή θερμοκρασία ζεστού νερού, καθόλου κρύο νερό. Ο ταχυθερμοσίφωνας ενεργοποιείται, όταν επιλέγεται το κρύο νερό.	/ Λάθος ρύθμιση της περιοριστικής διάταξης ζεστού νερού / Σταυροειδής ροή	/ Ρυθμίστε την περιοριστική διάταξη του ζεστού νερού / Αλλαγή φασίγγιου
/ Ο διακόπτης επιλογής δεν λειτουργεί	/ Άλατο / Ανεπαρκής πίεση νερού / Βλάβη στο διακόπτη επιλογής	/ Καθαρίστε τον ρυθμιστή νερού/ λιπάνετε τους στεγανωτικούς δακτυλίους / Αυξήστε την πίεση του νερού / Αλλάξτε το διακόπτη επιλογής

ΣΥΝΑΡΜΟΛΟΓΗΣΗ (βλ. Σελίδα 32) 

⚠ VARNOSTNA OPOZORILA

- ⚠ Pri montaži je treba nositi rokavice, da se preprečijo poškodbe zaradi zmečkanja ali urezov.
- ⚠ Ta izdelek se sme uporabljati le z namenom umivanja, vzdrževanja higiene in telesne nege.
- ⚠ Velike razlike v tlaku med priključkom za mrzlo in priključkom za toplo vodo je potrebno izravnati.

NAVODILA ZA MONTAŽO

- / Pred montažo je treba izdelek preveriti glede morebitnih transportnih poškodb. Po vgradnji transportne ali površinske poškodbe ne bodo več priznane.
- / Cevi in armaturo je treba montirati, izprati in preveriti po veljavnih standardih.
- / Upoštevati je treba pravilnike o inštalacijah, ki veljajo v posamezni državi.

TEHNIČNI PODATKI

Delovni tlak:	maks. 1 MPa
Priporočeni delovni tlak:	0,1 - 0,5 MPa
Preskusni tlak:	1,6 MPa
	(1 MPa = 10 bar = 147 PSI)
Temperatura tople vode:	maks. 70°C
Priporočena temperatura tople vode:	65°C
Termična dezinfekcija:	maks. 70°C / 4 min

Proizvod je zasnovan izključno za sanitarno vodo!

OPIS SIMBOLA

Ne smete uporabiti silikona, ki vsebuje ocatno kislino!



JUSTIRANJE (glejte stran 34)
Nastavitev omejevalnika tople vode. V povezavi s pretočnimi grelniki uporaba zapore tople vode ni priporočljiva.



MERE (glejte stran 31)



DIAGRAM PRETOKA
(glejte stran 31)
prost pretok

- ① Odvod prhe
- ② Odvod banje



UPRAVLJANJE (glejte stran 35)



ČIŠČENJE (glejte stran 38)



REZERVNI DELI
(glejte stran 36)

- XXX = Barve
- 000 = krom
- 340 = Brushed Black Chrome
- 800 = videz legiranega jekla



PRESKUSNI ZNAK (glejte stran 39)

NAPAKA	VZROK	POMOČ
/ Težko premikanje armature	/ Pokvarjen vložek, poopneno	/ Zamenjajte vložek
/ Iz armature kaplja	/ Pokvarjen vložek	/ Zamenjajte vložek
/ Prenizka temperatura tople vode, ni mrzle vode. Pretočni grelnik se sproži, kadar izberete mrzlo vodo.	/ Omejevalnik tople vode ni pravilno nastavljen	/ Nastavite omejevalnik tople vode
/ Preklopnik ne deluje	/ Križni tok	/ Zamenjajte vložek
	/ Obloge	/ Očistite premečnik/namastite obročno tesnilo
	/ Prenizek vodni tlak	/ Povečajte vodni tlak
	/ Preklopnik je pokvarjen	/ Zamenjajte preklopnik

MONTAŽA (glejte stran 32)

OHUTUSJUHISED

- ⚠ Kandke paigaldamisel muljumis- ja löikevigastuste vältimiseks kindaid.
- ⚠ Toodet tohib kasutada ainult pesemis-, hügieeni- ja kehapuhastamismärkidel.
- ⚠ Kui külma ja kuuma vee ühenduste surve on väga erinev, tuleb need tasakaalustada.

PAIGALDAMISJUHISED

- / Enne paigaldamist tuleb toodet kontrollida transportikahjustuste osas. Pärast paigaldamist ei tunnustata enam transporti- või pinnakahjustuste kaebuseid.
- / Voolikute ja segisti paigaldamisel, loputamisel ja kontrollimisel tuleb lähtuda kehtivatest normatiividest.
- / Vastavas riigis kehtivaid paigalduseeskirju tuleb järgida.

TEHNILISED ANDMED

Töörõhk	maks. 1 MPa
Soovitav töörõhk:	0,1 - 0,5 MPa
Kontrollsurve:	1,6 MPa (1 MPa = 10 baari = 147 PSI)
Kuuma vee temperatuur:	maks. 70°C
Soovitav kuuma vee temperatuur:	65°C
Termineline desinfektsioon:	maks. 70°C / 4 min

Toode on ette nähtud eranditult joogivee jaoks!

SÜMBOLITE KIRJELDUS

Ärge kasutage äädikhapet sisaldavat silikooni!



REGULEERIMINE (vt lk 34)
Sooja vee piirangu seadistamine. Ühenduses boileritega ei ole sooja vee blokeeringu soovitatav.



MÕÕTUDE (vt lk 31)



LÄBIVOOLUDIAGRAMM
(vt lk 31)
äravoolu surve
① Duši väljund
② Vanni väljund



KASUTAMINE (vt lk 35)



PUHASTAMINE (vt lk 38)



VARUOSAD
(vt lk 36)

XXX = Värvid
000 = kroom
340 = Brushed Black Chrome
800 = roostevaba optik



KONTROLLSERTIFIKAAT (vt lk 39)

RIKE	PÕHIJUS	LAHENDUS
/ Segisti käib raskelt	/ Tööelement on katkine, lubiastunud	/ Vahetage tööelement
/ Segisti tilgub	/ Tööelement on katkine	/ Vahetage tööelement
/ Liiga madal sooja vee temperatuur, külma vett pole. Läbivoolu boiler hakkab tööle, kui on valitud külm vesi.	/ Kuuma vee piirang valesti seatud / Ristvool	/ Seadke kuuma vee piirang / Vahetage tööelement
/ Ümberlülit ei tööta	/ Setted	/ Ümberlülit puhastamine / O-tihendite määrimine
	/ Vee surve liiga madal	/ Tõstke vee survet
	/ Ümberlülit defektne	/ Ümberlülit välja vahetada

PAIGALDAMINE (vt lk 32)

△ DROŠĪBAS NORĀDES

- △ Montāžas laikā, lai izvairītos no saspiedumiem un iegriezumiem, nepieciešams nēsāt cimdus.
- △ Šo produktu drīkst izmantot tikai, lai mazgātos, higiēnai un ķermeņa tīrīšanai.
- △ Jāizlīdzina spiediena atšķirības starp aukstā un karstā ūdens pievadiem.

NORĀDĪJUMI MONTĀŽAI

- / Pirms montāžas nepieciešams pārbaudīt, vai produktam transportēšanas laikā nav radušies bojājumi. Pēc iebūvēšanas bojājumi, kas radušies transportēšanas laikā, vai virsmas bojājumi netiek atzīti.
- / Cauruļvadi un armatūra ir jāuzstāda, jāizskalo un jāpārbauda saskaņā ar spēkā esošajiem standartiem.
- / Jāievēro attiecīgās valsts spēkā esošās montāžas prasības.

TEHNISKIE DATI

Darba spiediens:	maks. 1 MPa
Ieteicamais darba spiediens:	0,1 - 0,5 MPa
Pārbaudes spiediens:	1,6 MPa
	(1 MPa = 10 bar = 147 PSI)
Karstā ūdens temperatūra:	maks. 70°C
Ieteicamā karstā ūdens temperatūra:	65°C
Termiskā dezinfekcija:	maks. 70°C/4 min

Izstrādājums ir paredzēts tikai dzeramajam ūdenim!

SIMBOLU NOZĪME



Neizmanto silikonu, kas satur etiķskābi!



IEREGULĒŠANA (skat. lpp. 34)
Karsta ūdens ierobežotāja regulēšana. Kopā ar caurteces sildītājiem nav ieteicams izmantot ūdens bloķētāju.



IZMĒRUS (skat. lpp. 31)



CAURPLŪDES DIAGRAMMA (skat. lpp. 31)
brīva caurplūde

① Dušas izeja

② Vannas izeja



LIETOŠANA (skat. lpp. 35)



TĪRĪŠANA (skat. lpp. 38)



REZERVES DAĻAS (skat. lpp. 36)

XXX = Krāsu kodi

000 = hroma

340 = Brushed Black Chrome

800 = iebrauda



PĀRBAUDES ZĪME (skat. lpp. 39)

TRAUCĒJUMS

- / Iaucēkrāns smagi grozāms
- / Iaucēkrāns pil
- / Pārāk zema ūdens temperatūra, nav aukstā ūdens, izvēloties auksto ūdeni, sāk darboties caurteces sildītājs
- / Pārslēdzējs nestrādā

IEMESLS

- / Bojāta kartuša, aizkalkojusies
- / Bojāta kartuša
- / Nepareizi noregulāta karstā ūdens bloķēšana
- / Ūdens sajaukšanās
- / Nogulsnes
- / Nepietiekams ūdens spiediens
- / Bojāts pārslēdzējs

BOJĀJUMU NOVĒRŠANA

- / Nomainīt kartušu
- / Nomainīt kartušu
- / Noregulēt karstā ūdens ierobežošanu
- / Nomainīt kartušu
- / Tīriet pārslēdzēju/ eļļojiet blīvējošos gredzenus
- / Paaugstināt ūdens spiedienu
- / Nomainīt pārslēdzēju

MONTĀŽA (skat. lpp. 32)



⚠ SIGURNOSNE NAPOMENE

- ⚠ Prilikom montaže se radi sprečavanja prignječanja i posekotina moraju nositi rukavice.
- ⚠ Proizvod sme da se koristi samo za kupanje, tuširanje i ličnu higijenu.
- ⚠ Velika razlika u pritisku između vruće i hladne vode mora biti izbalansirana.

INSTRUKCIJE ZA MONTAŽU

- / Pre montaže se mora proveriti da li je proizvod oštećen pri transportu. Nakon ugradnje se ne priznaju nikakve reklamacije koje se odnose na površinska i transportna oštećenja.
- / Vodovi i armatura moraju biti postavljeni, isprani i testirani prema važećim normama.
- / Treba se pridržavati propisa koji u određenim zemljama važe za instalacije.

TEHNIČKI PODACI

Radni pritisak:	maks. 1 MPa
Preporučeni radni pritisak:	0,1 - 0,5 MPa
Probni pritisak:	1,6 MPa
	(1 MPa = 10 bar = 147 PSI)
Temperatura vruće vode:	maks. 70°C
Preporučena temperatura vruće vode:	65°C
Termička dezinfekcija:	maks. 70°C/4 min

Proizvod je koncipiran isključivo za pijaću vodu!

OPIS SIMBOLA



Nemojte koristiti silikon koji sadrži sircetnu kiselinu!



PODEŠAVANJE (vidi stranu 34)
Podešavanje ograničivača tople vode.
U kombinaciji sa protočnim bojlerima ne preporučuje se primena sistema za blokiranje dotoka tople vode.



MERE (vidi stranu 31)



DIJAGRAM PROTOKA
(vidi stranu 31)
slobodan protok

- ① Ogranak tuš
- ② Ogranak kada



RUKOVANJE (vidi stranu 35)



ČIŠĆENJE (vidi stranu 38)



REZERVNI DELOVI
(vidi stranu 36)

XXX = Oznake boja
000 = hrom
340 = Brushed Black Chrome
800 = dezen plemeniti čelik



ISPITNI ZNAK (vidi stranu 39)

SMETNIA	UZROK	POMOĆ
/ Ručica se zaglavila	/ Neispravna kartuša, nataloženi kamenac	/ Zamenite kartušu
/ Slavina kaplje	/ Neispravna kartuša	/ Zamenite kartušu
/ Preniska temperatura tople vode, nema hladne vode. Protočni bojler se pali iako je puštena hladna voda.	/ Ograničavač vruće vode nije dobro podešen	/ Podesite ograničavač vruće vode
/ Preusmerivač ne radi	/ Ukršteni tok vode	/ Zamenite kartušu
	/ Naslage	/ Čišćenje preusmerivača i podmazivanje O-prstenova
	/ Prenizak pritisak vode	/ Povećajte pritisak vode
	/ Preusmerivač je neispravan	/ Zamenite preusmerivač

MONTAŽA (vidi stranu 32)

⚠ SIKKERHETSHENVISNINGER

- ⚠ Bruk hansker under montasjen for å unngå klem- og kuttskader.
- ⚠ Produktet skal kun brukes for bade-, hygiene- og kroppshygiene.
- ⚠ Store trykkdifferanser mellom kaldt- og varmtvannstilkoblinger skal utlignes.

MONTAGEHENVISNINGER

- / Før montasjen skal produktet sjekkes for transportskader. Etter monteringen aksepteres ikke noen transport- eller overflateskader.
- / Ledningene og armaturen skal monteres, spyles og sjekkes iht. de gyldige normer.
- / Gjeldende retningslinjer for rørleggerarbeid i de enkelte land skal følges.

TEKNISKE DATA

Driftstrykk	maks. 1 MPa
Anbefalt driftstrykk:	0,1 - 0,5 MPa
Prøvetrykk	1,6 MPa
	(1 MPa = 10 bar = 147 PSI)
Varmtvannstemperatur	maks. 70°C
Anbefalt temperatur for varmt vann	65°C
Termisk desinfisering:	maks. 70°C / 4 min

Produktet er utelukkende designet for drikkevann!

SYMBOLBESKRIVELSE



Ikke bruk silikon som inneholder eddiksyre!



JUSTERING (se side 34)

Innstilling av varmtvannsbegrensning. I forbindelse med gjennomstrømningsvarmere er det ikke anbefalt å bruke en varmtvannssperre.



MÅL (se side 31)



GJENNOMSTRØMNINGSDIAGRAM

(se side 31)

fri gjennomstrømning

⓪ Utgang dusj

Ⓢ Utgang kar



BETJENING (se side 35)



RENGJØRING (se side 38)



SERVICEDELER

(se side 36)

XXX = Fargekode

000 = krom

340 = Brushed Black Chrome

800 = rustfritt stål optikk



PRØVEMERKE (se side 39)

FEIL	ÅRSAK	FEILRETTELSE
/ Armatur ikke lett bevegelig	/ Kartusi defekt, forkalkning	/ Kartusi byttes
/ Armatur drypper	/ Kartusi defekt	/ Kartusi byttes
/ For lav varmtvannstemperatur, ikke noe kaldtvann, gjennomstrømningsvarmvarmer slår seg på når det velges kaldt vann.	/ Varmtvannsbegrensning er feil innstilt	/ Varmtvannsbegrensning innstilles
	/ Krysstrømning	/ Kartusi byttes
/ Omstiller fungerer ikke	/ Avleiringer	/ Rengjøre omstiller/smøre O-ringer
	/ For lavt vanntrykk	/ Øke vanntrykk
	/ Omstiller defekt	/ Omstiller byttes

MONTASJE (se side 32) 

⚠ УКАЗАНИЯ ЗА БЕЗОПАСНОСТ

- ⚠ При монтажа трябва да се носят ръкавици, за да се избегнат наранявания поради притискане или порязване.
- ⚠ Позволено е използването на продукта само за къпане, хигиена и цели на почистване на тялото.
- ⚠ Големите разлики в налягането между изводите за студената и топлата вода трябва да се изравняват.

УКАЗАНИЯ ЗА МОНТАЖ

- / Преди монтажа продуктът трябва да се провери за транспортни щети. След монтажа не се признават транспортни или повърхностни щети.
- / Тръбопроводите и арматурата трябва да се монтират, промият и проверят в съответствие с валидните норми.
- / Трябва да бъдат спазвани валидните в съответните страни предписания за инсталиране.

ТЕХНИЧЕСКИ ДАННИ

Работно налягане:	макс. 1 МПа
Препоръчително работно налягане:	0,1 - 0,5 МПа
Контролно налягане:	1,6 МПа (1 МПа = 10 bar = 147 PSI)
Температура на горещата вода:	макс. 70°C
Препоръчителна температура на горещата вода:	65°C
Термична дезинфекция:	макс. 70°C/4 мин

Продуктът е разработен само за питейна вода!

ОПИСАНИЕ НА СИМВОЛИТЕ

Не използвайте силикон, съдържащ оцетна киселина!



ЮСТИРАНЕ (вижте стр. 34)
Настройка на ограничителя за топлата вода.
Във връзка с проточни нагреватели не се препоръчва блокировка за топлата вода



РАЗМЕРИ (вижте стр. 31)



ДИАГРАМА НА ПОТОКА
(вижте стр. 31)
свободен поток

- ① Изход разпръсквател
- ② Изход вана



ОБСЛУЖВАНЕ (вижте стр. 35)



ПОЧИСТВАНЕ (вижте стр. 38)



СЕРВИЗНИ ЧАСТИ
(вижте стр. 36)

XXX = Цветово кодиране
000 = хром
340 = Brushed Black Chrome
800 = оптика на благородна стомана



КОНТРОЛЕН ЗНАК (вижте стр. 39)

НЕИЗПРАВНОСТ	ПРИЧИНА	ПОМОЩ
/ Трудно подвижна арматура	/ Дефектна гилза, покрита с варовик	/ Сменете гилзата
/ Арматурата капе	/ Дефектна гилза	/ Сменете гилзата
/ Твърде ниска температура на топлата вода, няма студена вода. Проточният нагревател се задейства, когато се избере студена вода	/ Ограничението за топлата вода е грушно настроено / Кръстосване на потока	/ Настройте ограничението за топлата вода / Сменете гилзата
/ Превключвателят не функционира	/ Отлагания / Твърде малко налягане на водата / Дефектен превключвател	/ Почистете превключвателя / Смажете O-образните пръстени / Повишаване на налягането на водата / Сменете превключвателя

МОНТАЖ (вижте стр. 32) 

△ UDHËZIME SIGURIE

- △ Për të evituar lëndimet e pickimeve ose të prerjeve gjatë procesit të montimit duhet që të vishni doreza.
- △ Produkti duhet të përdoret vetëm qëllimet e banjave, të higjienës dhe të larjes së trupit.
- △ Ndryshimet e mëdha të presionit mes lidhjeve të ujit të ftohtë dhe atij të ngrohtë duhen ekuilibruar.

UDHËZIME PËR MONTIMIN

- / Përpara montimit duhet që produkti të kontrollohet për dëmtime nga transporti. Pas instalimit nuk do të njihet asnjë dëmtim nga transporti ose dëmtim i sipërfaqes.
- / Tubacionet dhe rubinetet duhet që të montohen, të shpëlahen dhe të kontrollohen sipas standardeve në fuqi
- / Duhet të respektohen linjat udhëzuese të instalimit, të vlefshme për vendet respektive.

TË DHËNA TEKNIKE

Presioni gjatë punës	maks. 1 MPa
Presioni i rekomanduar:	0,1 - 0,5 MPa
Presioni për provë:	1,6 MPa
	(1 MPa = 10 bar = 147 PSI)
Temperatura e ujit të ngrohtë	maks. 70°C
Temperatura e rekomanduar e ujit të ngrohtë:	65°C
Dezinfektim Termik:	maks. 70°C/4 min

Produkti është projektuar ekskluzivisht për ujë të pijshëm!

PËRSHKRIMI I SIMBOLIT

Mos përdorni silikon që në përbërje ka acid acetik.



JUSTIMI (shih faqen 34)
Rregullimi i kufizimit me ujë të nxehtë. Nje kombinim me një bojler ujit nuk është i rekomanduar.



PËRMASAT (shih faqen 31)



DIAGRAMI I QARKULLIMIT
(shih faqen 31)
rrjedhja e lirë

- ⓪ Dalja e spërkatëses
- Ⓢ Dalja e vaskës



PËRDORIMI (shih faqen 35)



PASTRIMI (shih faqen 38)



PJESËT E SERVISIT
(shih faqen 36)

- XXX = Kodimi me anë të ngjyrave
- 000 = krom
- 340 = Brushed Black Chrome
- 800 = optikë çeliku



SHENJA E KONTROLLIT
(shih faqen 39)

DEMTIM	SHKAKU	NDIHME
/ Armatura punon rende	/ Kartusha me defekt, me kalk	/ Kembeni kartushen
/ Armatura pikon	/ Kartusha me defekt	/ Kembeni kartushen
/ Temperaturë e ulët e ujit të ngrohtë, nuk ka ujë të ftohtë. Ngrohësi elektrik i ujit ndizet kur zgjidhet uji i ftohtë.	/ Kufiri i ujit të ngrohtë është regjistruar gabim	/ Regjistroni kufirin e ujit të ngrohtë
/ Kalibruesi nuk funksionon	/ Rriedhie e krygëzuar.	/ Kembeni kartushen
	/ Dekompozimet	/ Pastroni ndërruesin e pozicionit/ Vajosni unazat ⓪
	/ Presion shumë i ulët i ujit	/ Rrisni presionin e ujit
	/ Kalibruesi me defekt	/ kembeni kalibruesin

MONTIMI (shih faqen 32) 



هام! لا تستخدم السليكون الذي يحتوي على أحماض!

(راجع صفحة 34) ضبط تحديد المياه الدافئة. لا ينصح باستخدام محدد المياه الدافئة مع سخان المياه الوتقي.

(راجع صفحة 31)

(راجع صفحة 31)
النتدفق الحر

① صرف الرشاش
② صرف البانيو

(راجع صفحة 35)

(راجع صفحة 38)

(راجع صفحة 36)

XXX = الألوان

000 = كروم

340 = Brushed Black Chrome

800 = مظهر الإستنليس ستيل

(راجع صفحة 39)



⚠ يجب إرتداء قفازات لليد أثناء التركيب لتجنب حدوث أخطار الإنحشار أو الجروح.

⚠ لا يجب استخدام المنتج إلا في أغراض الاستحمام والأغراض الصحية وأغراض تنظيف الجسم.

⚠ يجب أن يكون تيار الماء الساخن والماء البارد متعادلين في الضغط.



/ قبل القيام بعملية التركيب، يجب فحص المنتج للتأكد من خلوه من أية تلفيات ناتجة عن النقل. بعد القيام بعملية التركيب، لن يتم الاعتراف بوجود أية تلفيات سطحية أو تلفيات ناتجة عن عملية النقل.

/ يجب تركيب وغسيل واختبار التوصيلات وخلطات المياه طبقاً للمعايير السارية.

/ يجب مراعاة القواعد الخاصة بالتركيب وأعمال السباكة وفقاً للوائح الخاصة بكل بلد.



ضغط التشغيل: الحد الأقصى 1 ميجابسكال

ضغط التشغيل الموصى به: 0,1 - 0,5 ميجابسكال

ضغط الاختبار: 1,6 ميجابسكال

(1 ميجابسكال = 10 بار = 147 PSI)

درجة حرارة الماء الساخن: الحد الأقصى 70°C

درجة الحرارة الموصى بها للماء الساخن: 65°C

تعقيم حراري: الحد الأقصى 4/70°C الدقيقة

المنتج مخصص فقط لماء الشرب!



/ الخلاط ثقيل الحركة / الخرطوشة تالفة، تراكم عليها الجير / قم بتغيير الخرطوشة

/ تساقط قطرات مياه من الخلاط / الخرطوشة تالفة / قم بتغيير الخرطوشة

/ درجة حرارة الماء الساخن منخفضة للغاية، ولا يوجد ماء بارد. سخان المياه الفوري يعمل عند استخدام الماء البارد. / محدد الماء الساخن مضبوط بشكل خاطيء / قم بضبط محدد الماء الساخن

/ المحول لا يعمل / الرواسب / اندفاع متعكس للمياه / قم بتغيير الخرطوشة

/ تنظيف الخلاط وتشحيم الحلقة الدائرية. / الرصاص / قم بتغيير الخرطوشة

/ ضغط الماء منخفض للغاية / ارفع ضغط الماء

/ المحول تالف / قم بتغيير المحول

التركيب (راجع صفحة 32)



AXOR Starck
10416XXX / 10416003

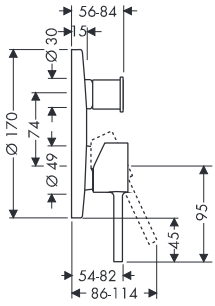

AXOR Starck
10414000

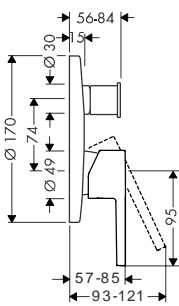

AXOR Starck X
10445000

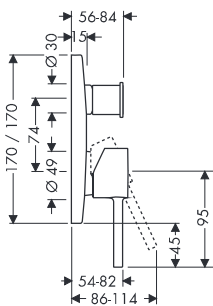

AXOR Uno²
38425000

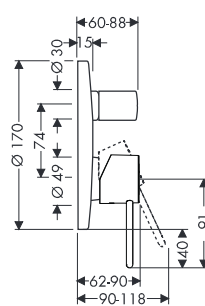

AXOR Citterio M
34425000 / 34425003

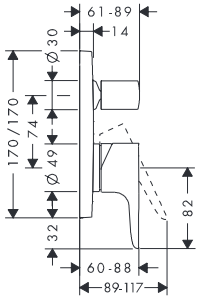

AXOR Citterio
39455000 / 39455003

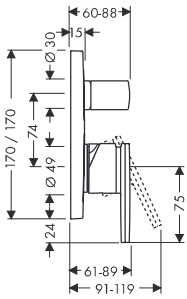

AXOR Citterio E
36455000 / 36455003

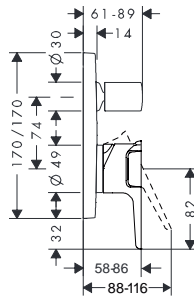

AXOR Starck 10416000 / 10416003 / 10414000
 AXOR Starck X 10445000
 AXOR Uno² 38425000
 AXOR Citterio M 34425000 / 34425003
 AXOR Citterio 39455000 / 39455003
 AXOR Citterio E 36455000 / 36455003

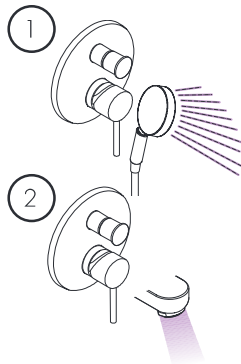
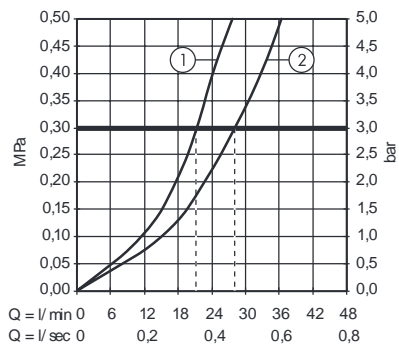

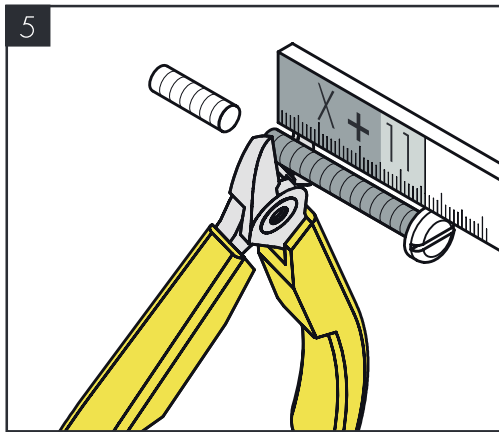
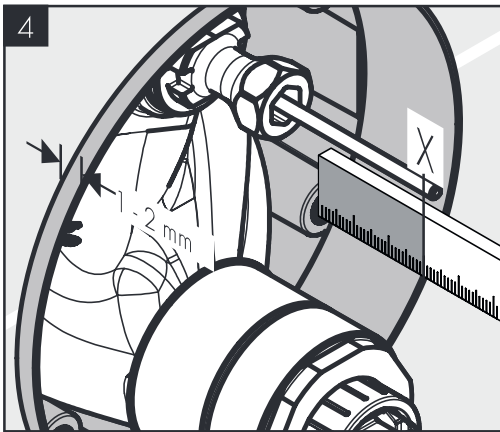
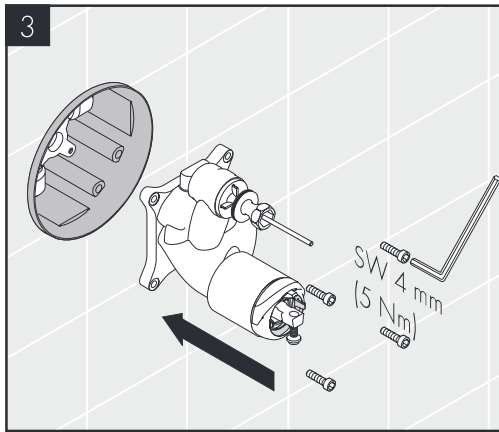
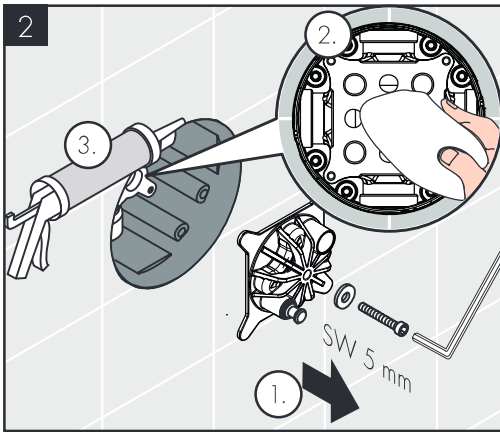
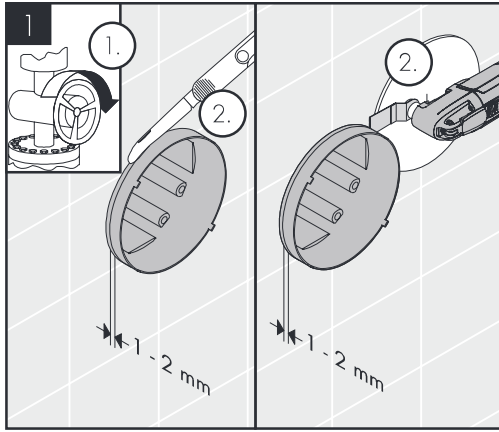
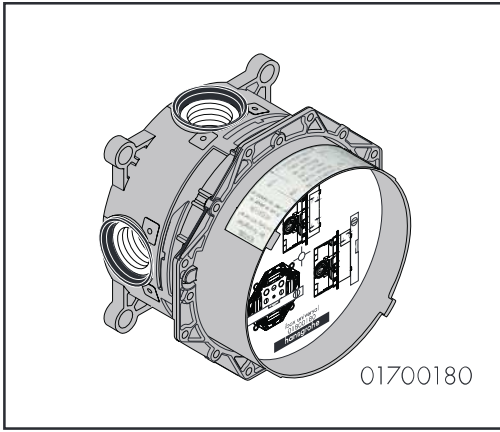

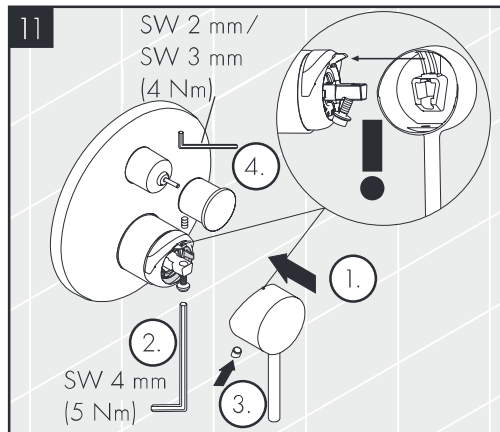
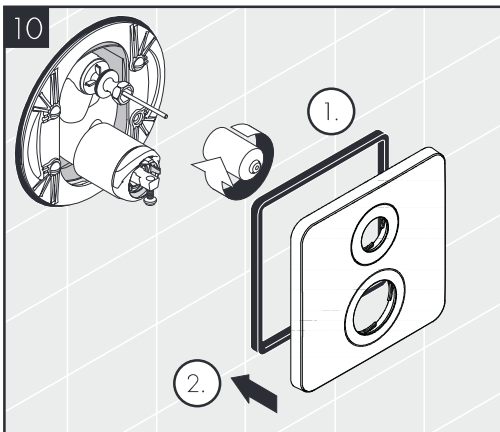
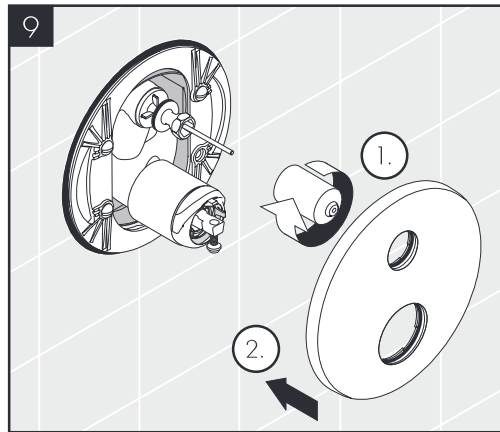
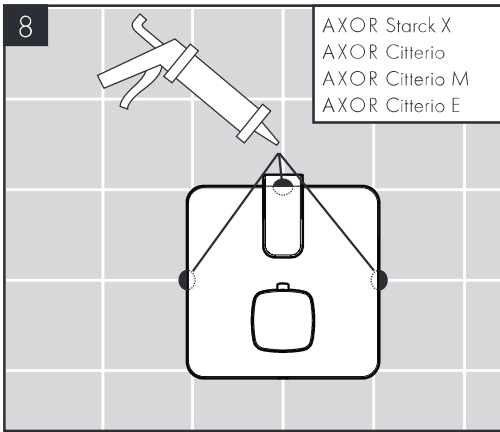
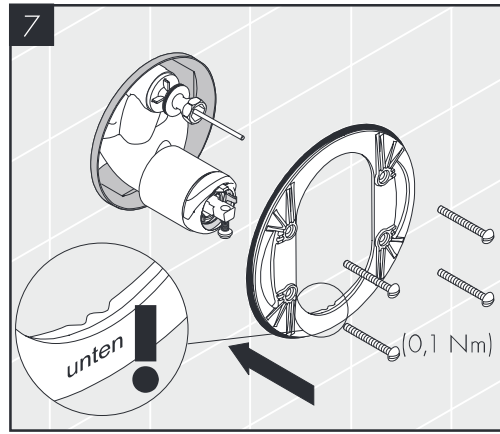
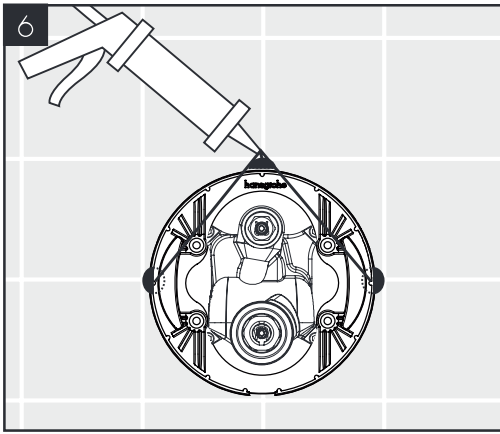

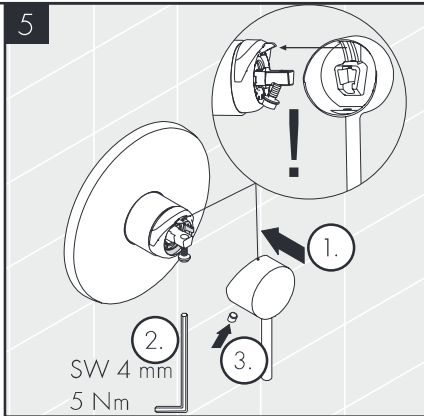
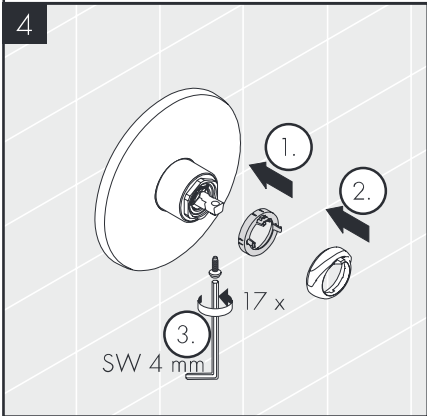
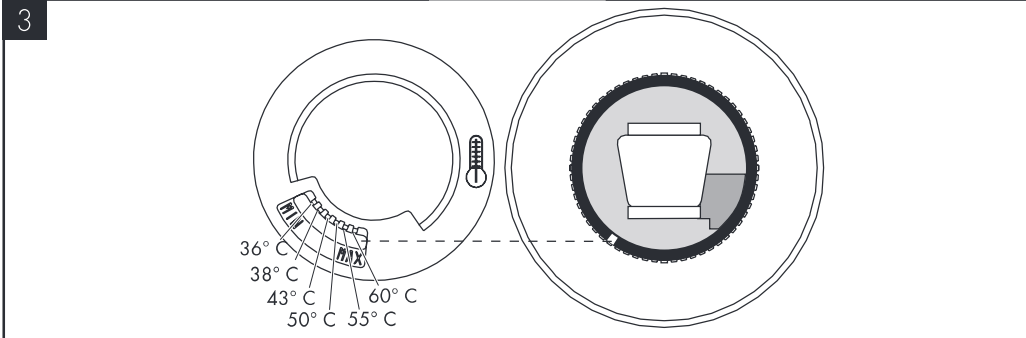
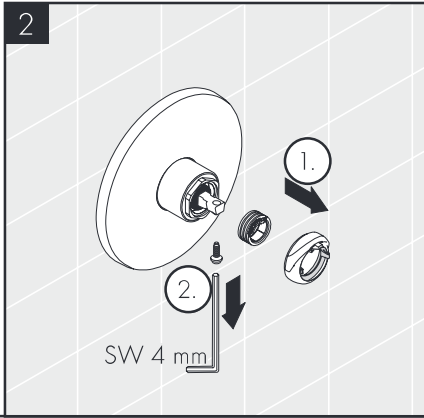
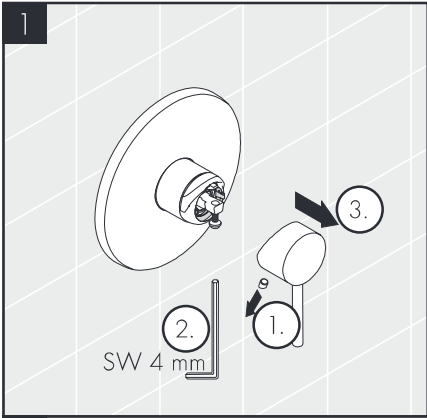



öffnen/ouvert/open/aperto/abierto/open/ðbne/abrir/otworzyć/otevřít/otvorif/开/открыть/nyitás/avaaminen/öppna/atidaryti/Otvoranje/açmak/deschide/ανοικτό/odpreti/avage/atvĕrit/otvoriti/ðrne/отваряне/hape/فتح



schließen/fermé/close/chiodere/cerrar/sluiten/lukke/fechar/zamknąć/zavřít/uzavrieť/关/закреть/bezárás/sulkeminen/sianga/uždaryti/Zatvaranje/kapatmak/inchide/κλειστό/zapreti/sulgege/aizvērt/zatvori/lukke/затваряне/mbylle/إغلاق

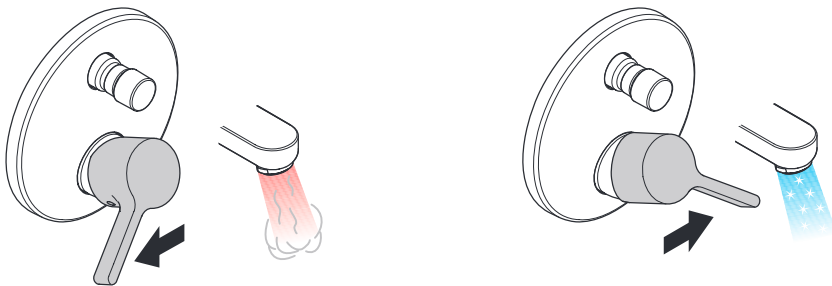

warm/chaud/hot/caldo/caliente/warm/varmt/quente/ciepła/teplá/teplá/热/горячая/meleg/lämmin/varmt/karštas/Vruća voda/sıcak/cald/ζεστό/toplo/kuum/karsts/topla/varm/топло/i ngrohtë/ساخن

kalt/froid/cold/freddo/frio/koud/koldt/fria/zimna/studená/studená/冷/холодная/hideg/kylmä/kallt/šaltas/Hladno/soğuk/rece/קרוב/mrzlo/kuļm/auksts/hladno/kaldt/судно/i ftohtë/بارد

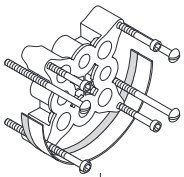
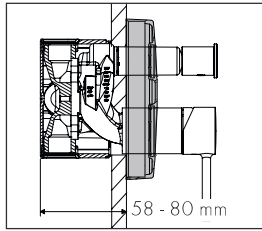
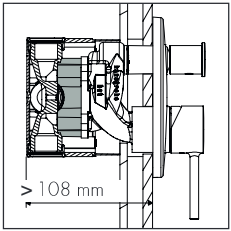
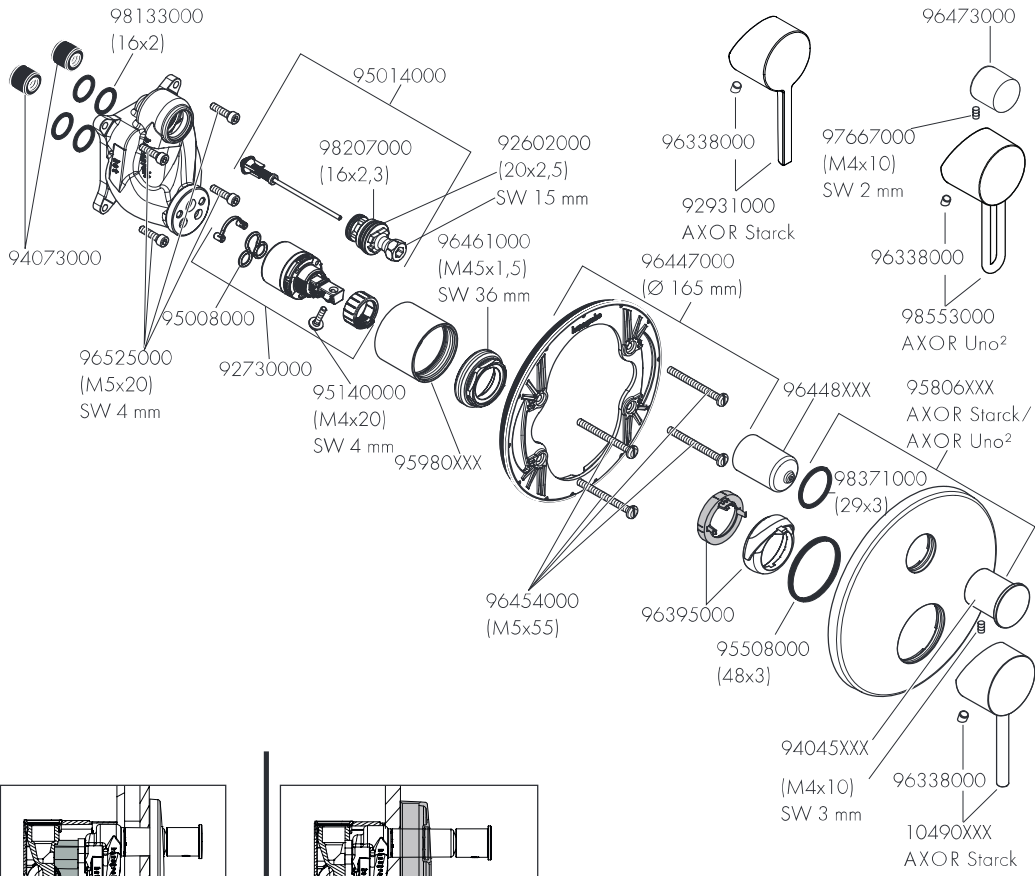

13595000
25 mm

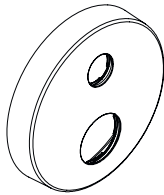

14961000
AXOR Starck /
AXOR Uno
(33 mm)

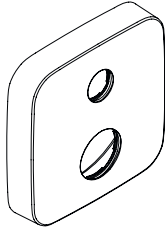

14972000
AXOR Citterio M /
AXOR Citterio E
(33 mm)

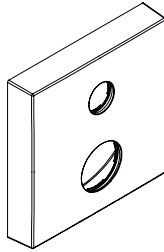

14967000
AXOR Citterio /
AXOR Starck X
(33 mm)



AXOR Starck X 10445000 / AXOR Citterio M 34425000 / AXOR Citterio M 34425003 /
 Citterio E 36455000 / Citterio E 36455003 / AXOR Citterio 39455000 / AXOR Citterio 39455003

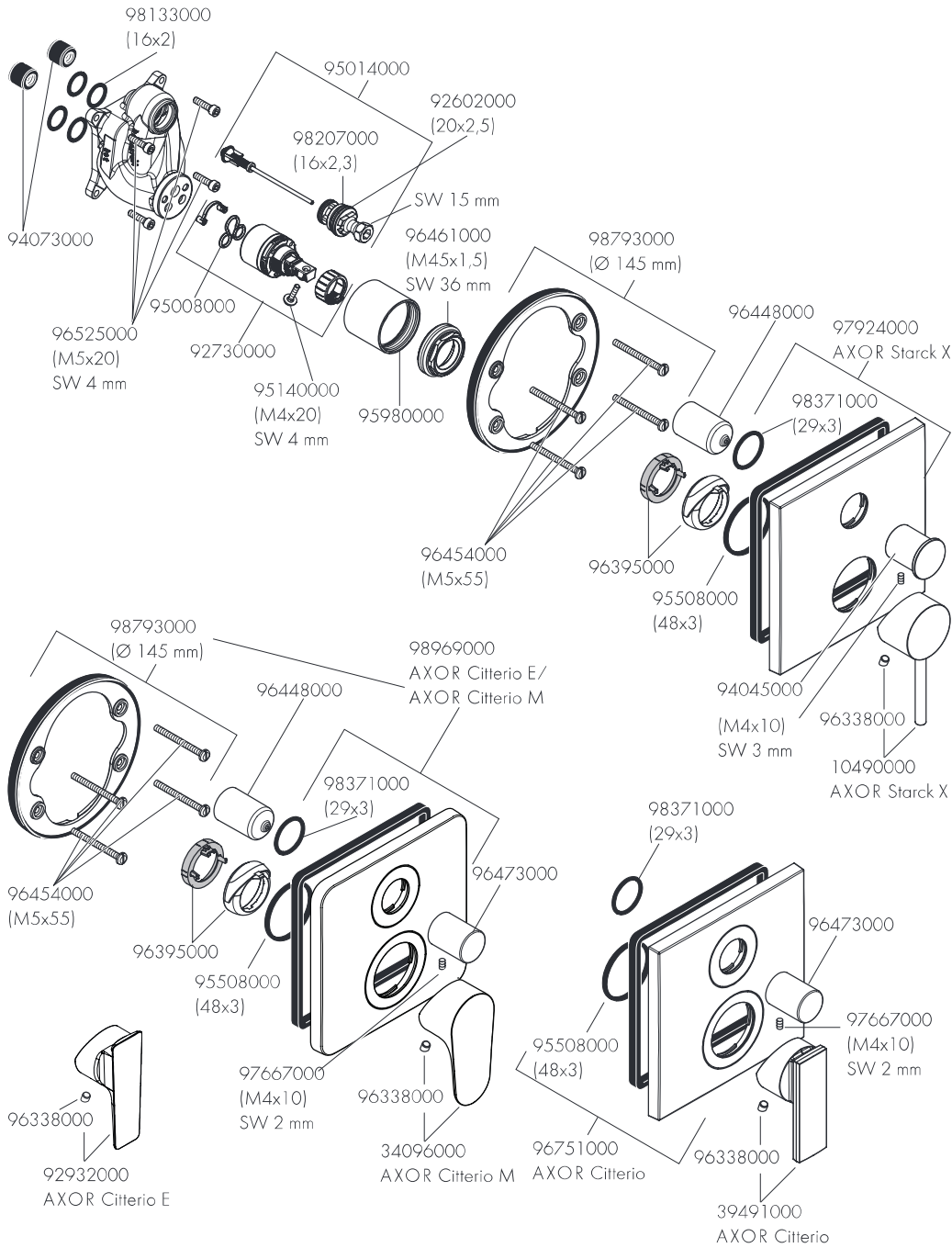



- DE / Reinigungsempfehlung / Garantie / Kontakt
- FR / Recommandation pour le nettoyage / Garanties / Contact
- EN / Cleaning recommendation / Warranty / Contact
- IT / Raccomandazione di pulizia / Garanzia / Contatto
- ES / Recomendaciones para la limpieza / Garantía / Contacto
- NL / Reiniging en Garantie / Contact
- DK / Rensning og Garanti / Kontakt
- PT / Recomendações de limpeza / Garantia / Contacto
- CZ / Doporučení dotýc se péčlivosti / Garancia / Kontakt
- SK / Doporučenia pre čistenie / Záruka / Kontakt
- HK / 清潔指南 / 担保 / 接觸
- RU / Рекомендации по очистке / Гарантия / Контакты
- HU / Tisztítási tanácsok / Garancia / érintkezés
- FI / Huuho- ja puhdistusohjeet / Takuu / Kosketus
- SE / Rengöringsrekommendationer / Garanti / Kontakt
- PL / Wskazywanie / Gwarancja / Kontakt
- HR / Preporuke za čišćenje / Garancija / Kontakt
- TR / Temizleme önerisi / Garanti / Temas
- RO / Recomandări pentru curățare / Garanție / Contact
- EL / Σύσταση καθαρισμού / Εγγύηση / επαφή
- SI / Poročilo o čiščenju / Garancija / Kontakt
- EU / Huuho- ja puhdistusohjeet / Garanti / Kontakt
- LT / Tiesana ieteikimai / Garanti / Kontaktai
- HR / Preporuke za čišćenje / Garancija / Kontakt
- NL / Reiniging voor renging / Garanti / Kontakt
- BG / Препоръка за почистване / Гаранция / Контакт
- SK / Këshilla për pastrimit / Garancia / Kontakt
- KR / 세정시 권장사항 / 품질보증 / 접촉
- AR / نصيحة تنظيف



cleaning recommendation

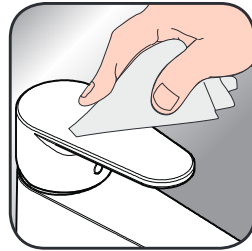

cleaning recommendation









cleaning recommendation



cleaning recommendation



	P-IX	DVGW	SVGW	ACS	WRAS	KIWA		ETA
10414000				X			1392	
10416XXX	PA-IX 9709/ICC	CQ0125	X	X	X	X	1392	 1.42/18751
10445000	PA-IX 9709/ICC	CQ0125	X	X	X	X	1392	 1.42/18751
34425000	PA-IX 9709/ICC	CQ0125	X	X	X		1392	 1.42/18751
36455000				X			1392	
38425000	PA-IX 9709/ICC	CQ0125	X	X	X	X	1392	 1.42/18751
39455000	PA-IX 9709/ICC	CQ0125	X	X	X	X	1392	 1.42/18751



AXOR

AXOR / Hansgrohe SE
Austraße 5-9
77761 Schiltach
Deutschland

info@axor-design.com
axor-design.com

01/2018
9.09451.12