



Biztonsági utasítások

- ⚠ A szerelésnél a zúzódások és vágási sérülések elkerülése érdekében kesztyűt kell viselni.
- ⚠ A zuhanyfej karja csak a zuhanyfej tartására alkalmas, és nem szabad más tárgyakkal megterhelni!
- ⚠ Gyermek, valamint testileg, szellemileg fogyatékos és / vagy érzékelésben korlátozott személyek nem használhatják felügyelet nélkül a terméket. Alkohol és kábítószer befolyása alatt álló személyek nem használhatják a terméket.
- ⚠ Kerülni kell a zuhansugár érintkezését érzékeny testrészekkel (pl. szemek). Be kell tartani a megfelelő távolságot a zuhanyfej és a test között.
- ⚠ A terméket csak fürdéshez, mosakodáshoz, és egészségügyi tisztálkodáshoz szabad használni.

Szerelési utasítások

- A szerelés előtt ellenőrizni kell, hogy a terméknek nincs-e szállítási sérülése. Beépítés után a szállítási- vagy felületi sérüléseket nem ismerik el.
- A vezetékeket és a csaptelepet az érvényes szabványoknak megfelelően kell felszerelni, öblíteni és ellenőrizni
- Az egyes országokban érvényes installációs irányelveket be kell tartani.
- A termék képzett szakember általi felszerelése esetén ügyelni kell arra, hogy a rögzítési felület teljesen síma legyen (ne legyen kiálló fuga vagy csempe), a fal szerkezete a termék felszerelésére alkalmas legyen, és ne legyen gyenge pontja.

Műszaki adatok

Üzemi nyomás:	max. 0,6 MPa
Ajánlott üzemi nyomás 27378XXX / 27337XXX:	0,15 – 0,4 MPa
Ajánlott üzemi nyomás 26466XXX / 26467XXX:	0,1 – 0,4 MPa
Ajánlott üzemi nyomás 27384XXX / 27385XXX: (1 MPa = 10 bar = 147 PSI)	0,2 – 0,4 MPa
Forróvíz hőmérséklet:	max. 60 °C
Termikus fertőtlenítés:	max. 70 °C / 4 perc

A terméket kizárólag ivóvízhez tervezték!

Szimbólumok leírása



Ne használjon ecetsavtartalmú szilikon!



Méretet (lásd a oldalon 31)



Átfolyási diagramm

(lásd a oldalon 31)

- ① Rain
- ② RainAir



Használat (lásd a oldalon 39)

A fejszuhany kiürítéséhez ezt használat után állítsa enyhén ferdén.



Tisztítás (lásd a oldalon 40) és mellékelt brossúrával



Tartozékok (lásd a oldalon 42)



Vizsgajel (lásd a oldalon 48)



Falra szerelés lásd a oldalon 34



Mennyezetre szerelés lásd a oldalon 36



Turvallisuusohjeet

- Asennuksessa on käytettävä käsineitä puristumien ja viiltojen aiheuttamien tapaturmien estämiseksi.
- Pääsuihkun varsi on tarkoitettu vain kannattamaan pääsuihkua. Sitä ei saa kuormittaa muilla esineillä!
- Lapset ja ruumiillisesti, henkisesti ja/tai aistillisesti rajoittuneet aikuiset eivät saa käyttää suihkujärjestelmää ilman valvontaa. Alkoholien tai huumeiden vaikutuksessa olevat henkilöt eivät saa käyttää suihkujärjestelmää.
- Suihkuveden kontaktia herkempien ruumiinosien (esim. silmien) kanssa on vältettävä. Suihkun ja vartalon välissä on oltava riittävä väli.
- Suihkujärjestelmää saa käyttää ainoastaan kylpy-, hygienia- ja puhdistustarkoituksiin.

Asennusohjeet

- Ennen asennusta on tarkastettava tuotteen mahdolliset kuljetusvahingot. Asennuksen jälkeen kuljetus- ja pintavaurioita ei hyväksytä.
- Putket ja hana on asennettava, huuhdeltava ja tarkastettava voimassa olevien standardien mukaisesti.
- Jokaisessa maassa on noudatettava siellä päteviä asennusohjeita.
- Pätevän ammattihenkilöstön asentaessa tuotetta on otettava huomioon, että kiinnityspinnan on oltava koko kiinnitysalueelta tasainen (ei korkeita saumoja tai laatojen yhtymäkohtia), seinän rakenne soveltuu tuotteen asennukseen eikä siinä ole heikkoja kohtia.

Tekniset tiedot

Käyttöpaine:	maks. 0,6 MPa
Suosittelut käyttöpaine 27378XXX / 27337XXX:	0,15 – 0,4 MPa
Suosittelut käyttöpaine 26466XXX / 26467XXX:	0,1 – 0,4 MPa
Suosittelut käyttöpaine 27384XXX / 27385XXX:	0,2 – 0,4 MPa
(1 MPa = 10 bar = 147 PSI)	
Kuuman veden lämpötila:	maks. 60°C
Lämpödesinfektio:	maks. 70°C / 4 min

Tuote on suunniteltu käytettäväksi ainoastaan juomaveden kanssa!

Merkin kuvaus



Älä käytä etikkahappopitoista silikonia!



Mitat (katso sivu 31)



Virtausdiagrammi

(katso sivu 31)

- ① Rain
- ② RainAir



Käyttö (katso sivu 39)

Tyhjennä pääsuihku asettamalla se käytön jälkeen hieman vinoon.



Puhdistus (katso sivu 40) ja oheinen esite



Varaosat (katso sivu 42)



Koestusmerkki (katso sivu 48)



Seinäasennus katso sivu 34



Kattoasennus katso sivu 36



⚠ Säkerhetsanvisningar

- ⚠ Handskar ska bäras under monteringsarbetet så att man kan undvika kläm- och skärskadorgen werden.
- ⚠ Armen som håller huvudduschen är bara konstruerad för detta; den får inte belastas med andra föremål!
- ⚠ Barn samt vuxna med fysiska, psykiska eller sensoriska funktionshinder får inte använda produkten ensam. Personer som är påverkade av alkohol eller droger får inte använda produkten.
- ⚠ Undvik att rikta duschstrålarna mot känsliga kroppsdelar (t. ex. ögonen). Det måste finnas ett tillräckligt stort avstånd mellan duschen och kroppen.
- ⚠ Produkten får bara användas till kroppshygien med bad och dusch.

Monteringsanvisningar

- Det måste undersökas om produkten har transportskador innan den monteras. Efter monteringen accepteras inga transport- eller ytskiktsskador.
- Ledningarna och blandaren måste monteras, spolas igenom och kontrolleras enligt de gällande normerna.
- De installationsriktlinjer som gäller i länderna ska följas.
- När kvalificerad fackpersonal monterar produkten är det viktigt att fästytan är plan över hela festsättningsområdet (inga fogar som sticker ut eller kakelförskjutning) och att väggstrukturen är lämplig för en montering av produkten och inte har några svaga punkter.

Tekniska data

Driftstryck:	max. 0,6 MPa
Rek. Driftstryck 27378XXX / 27337XXX:	0,15 – 0,4 MPa
Rek. Driftstryck 26466XXX / 26467XXX:	0,1 – 0,4 MPa
Rek. Driftstryck 27384XXX / 27385XXX: (1 MPa = 10 bar = 147 PSI)	0,2 – 0,4 MPa
Varmvattentemperatur:	max. 60 °C
Termisk desinfektion:	max. 70 °C / 4 min

Produkten är enbart avsedd för dricksvatten!

Symbolbeskrivning



Använd inte silikon som innehåller ättiksyra!



Måtten (se sidan 31)



Flödesschema

(se sidan 31)

- ① Rain
- ② RainAir



Hantering (se sidan 39)

Ställ huvudduschen lätt lutande efter användningen för att tömma den.



Rengöring (se sidan 40) och medföljande broschyr



Reservdelar (se sidan 42)



Testsigill (se sidan 48)



Sienos montavimas se sidan 34



Dangų montavimas se sidan 36



Saugumo technikos nurodymai

- ⚠ Apsaugai nuo užspaudimo ir įsijovimo montavimo metu mūvėkite pirštines.
- ⚠ Dušo laikiklis skirtas tik dušo galvutei laikyti, todėl neturi būti apkraunamas kitokiais daiktais!
- ⚠ Gaminį draudžiama naudoti vaikams, taip pat suaugusiems su fizine, dvasine negale ir (arba) sensorikos sutrikimais. Gaminį taip pat draudžiama naudoti asmenims, apsvaigusiems nuo alkoholio arba narkotikų.
- ⚠ Būtina vengti dušo vandens srovės kontakto su jautriomis kūno vietomis (pvz., akimis). Todėl būtina laikytis tinkamu atstumu nuo dušo.
- ⚠ Gaminys turi būti naudojamas tik maudymuisi, kūno higienai ir švarai palaikyti.

Montavimo instrukcija

- Prieš montuojant būtina patikrinti, ar gaminys nebuvo pažeistas transportavimo metu. Sumontavus pretenzijos dėl transportavimo ir paviršiaus pažeidimų nepriimamos.
- Vamzdžiai ir sujungimai turi būti montuojami, plaunami ir tikrinami pagal galiojančias normas.
- Laikykitės atitinkamoje šalyje galiojančių direktyvų dėl įrengimo.
- Atlikdami montavimo darbus, kvalifikuoti darbuotojai turi atkreipti dėmesį, kad pritvirtinimo plokštuma būtų lygi (be išsikišusių siūlių ar perkreiptų plytelių), sienų konstrukcija tinktų gaminiui montuoti ir neturėtų jokių trūkumų.

Techniniai duomenys

Darbinis slėgis: ne daugiau kaip 0,6 MPa
 Rekomenduojamas slėgis 27378XXX / 27337XXX: 0,15 – 0,4 MPa
 Rekomenduojamas slėgis 26466XXX / 26467XXX: 0,1 – 0,4 MPa
 Rekomenduojamas slėgis 27384XXX / 27385XXX: 0,2 – 0,4 MPa
 (1 MPa = 10 barų = 147 PSI)
 Karšto vandens temperatūra: ne daugiau kaip 60°C
 Terminis dezinfekavimas: ne daugiau kaip 70°C / 4 min

Produktas skirtas tik geriamajam vandeniui!

Simbolio aprašymas



Nenaudokite silikono, kurio sudėtyje yra acto rūgšties!



Išmatavimai (žr. psl. 31)



Pralaidumo diagrama

(žr. psl. 31)

- ① Rain
- ② RainAir



Eksplotacija (žr. psl. 39)

Kad ištuštintumėte dušo galvą, pasinaudoję nustatykite ją šiek tiek įstrižai.



Valymas (žr. psl. 40) ir pridedama brošiūra



Atsarginės dalys (žr. psl. 42)



Bandymo pažyma (žr. psl. 48)



Sienos montavimas žr. psl. 34



Dangų montavimas žr. psl. 36



Sigurnosne upute

- ⚠ Prilikom montaže se radi sprječavanja prignječenja i posjekotina moraju nositi rukavice.
- ⚠ Nosač tuša iznad glave je dimenzioniran samo za držanje danog tuša i ne smije se opterećivati drugim predmetima!
- ⚠ Djeca, kao i tjelesno, mentalno i/ili senzorno hendikepirane odrasle osobe ne smiju se koristiti proizvodom bez nadzora. Osobe koje su pod utjecajem alkohola ili droga ne smiju se koristiti proizvodom.
- ⚠ Mora se izbjegavati kontakt mlaza iz tuša s osjetljivim dijelovima tijela (npr. očima). Tijelo korisnika mora biti dovoljno udaljeno od tuša.
- ⚠ Proizvod se smije primjenjivati samo za kupanje, tuširanje i osobnu higijenu.

Upute za montažu

- Prije montaže mora se provjeriti je li proizvod oštećen prilikom transporta. Nakon ugradnje se ne priznaju nikakve reklamacije koje se odnose na površinska i transportna oštećenja.
- Cijevi i armatura moraju biti postavljeni, isprani i testirani prema važećim normama.
- Obvezno se moraju uvažiti propisi o instalacijama koji vrijede u dotičnoj zemlji.
- Kada proizvod montira kvalificirano stručno osoblje treba paziti da čitava površina na koju se učvršćuje bude ravna (bez istaknutih fuga ili krivljenja pločica), da je zidna konstrukcija primjerena montaži proizvoda te da nema slabih mjesta.

Tehnički podatci

Najveći dopušteni tlak:	tlak 0,6 MPa
Preporučeni tlak 27378XXX / 27337XXX:	0,15 – 0,4 MPa
Preporučeni tlak 26466XXX / 26467XXX:	0,1 – 0,4 MPa
Preporučeni tlak 27384XXX / 27385XXX: (1 MPa = 10 bar = 147 PSI)	0,2 – 0,4 MPa
Temperatura vruće vode:	tlak 60 °C
Termička dezinfekcija:	tlak 70 °C / 4 min

Proizvod je koncipiran isključivo za pitku vodu!

Opis simbola



Nemojte koristiti silikon koji sadrži octenu kiselinu!



Mjere (pogledaj stranicu 31)



Dijagram protoka
(pogledaj stranicu 31)

- ① Rain
- ② RainAir



Upotreba (pogledaj stranicu 39)

Nakon korištenja neznatno nagnite tuš iznad glave u stranu kako biste ga ispraznili.



Čišćenje (pogledaj stranicu 40) i priložena brošura



Rezervni dijelovi (pogledaj stranicu 42)



Oznaka testiranja (pogledaj stranicu 48)



Montaža na zid pogledaj stranicu 34



Montaža na strop pogledaj stranicu 36



Güvenlik uyarıları

- ⚠ Montaj esnasında ezilme ve kesilme gibi yaralanmaları önlemek için eldiven kullanılmalıdır.
- ⚠ Başlıklı püskürtücü kolu yalnızca başlıklı püskürtücünün tutulması için tasarlanmıştır, başka nesnelere üzerine yük bindirilmemelidir!
- ⚠ Bedensel, ruhsal ve/veya sensörük engelli çocuk ve yetişkinler gözetimsiz olarak duş sistemini kullanmamalıdır. Alkol veya uyuşturucu etkisinde olanlar duş sistemini kullanmamalıdır.
- ⚠ Püskürtme başlıklarının hassas organlara teması (örn. gözler) önlenmelidir. Püskürtücü ile beden arasında yeterli mesafe bırakılmalıdır.
- ⚠ Duş sistemi yalnızca banyo, hijyen ve beden temizliği amaçları doğrultusunda kullanılabilir.

Montaj açıklamaları

- Montaj işleminden önce ürün nakliye hasarları yönünden kontrol edilmelidir. Montaj işleminden sonra nakliye veya yüzey hasarları için sorumluluk üstlenilmemektedir.
- Boruların ve armatürün montajı, yıkanması ve kontrolü geçerli normlara göre yapılmalıdır.
- Ülkelerde geçerli kurulum yönetmeliklerine riayet edilmelidir.
- Ürünün yetkili uzman personel tarafından montajı yapılırken, sabitleme yüzeyinin sabitleme planının tüm alanında bulunduğu (derz veya fayans kayması olmamalıdır), duvar yapısının ürünün montajı için uygun olduğuna ve zayıf noktaları bulunmadığına dikkat edilmelidir.

Teknik bilgiler

İşletme basıncı:	azami 0,6 MPa
Tavsiye edilen işletme basıncı 27378XXX / 27337XXX:	0,15 – 0,4 MPa
Tavsiye edilen işletme basıncı 26466XXX / 26467XXX:	0,1 – 0,4 MPa
Tavsiye edilen işletme basıncı 27384XXX / 27385XXX: (1 MPa = 10 bar = 147 PSI)	0,2 – 0,4 MPa
Sıcak su sıcaklığı:	azami 60°C
Termik dezenfeksiyon:	azami 70°C / 4 dak

Ürün sadece şebeke suyu için tasarlanmıştır!

Simge açıklaması



Asetik asit içeren silikon kullanmayın!



Ölçüleri (bakınız sayfa 31)



Akış diyagramı

(bakınız sayfa 31)

① Rain

② RainAir



Kullanımı (bakınız sayfa 39)

Kafa duşunu boşaltmak için kullanımdan sonra hafif eğri durmasını sağlayın.



Temizleme (bakınız sayfa 40) ve birlikte verilen broşür



Yedek Parçalar (bakınız sayfa 42)



Kontrol işareti (bakınız sayfa 48)



Duvara montaj bakınız sayfa 34



Tavana montaj bakınız sayfa 36



Instrucțiuni de siguranță

- ⚠ La montare utilizați mănuși pentru evitarea contuziunilor și tăierii mâinilor.
- ⚠ Brațul parei de duș este destinat doar pentru a susține para, acesta nu poate fi prevăzut cu alte obiecte.
- ⚠ Copiii și adulții cu dizabilități corporale, mintale și senzoriale nu pot utiliza sistemul de duș nesupravegheați. De asemenea este interzisă utilizarea sistemului de duș de către persoane, care se află sub influența alcoolului sau a drogurilor.
- ⚠ Evitați contactul jetului de apă cu părțile de corp sensibile (de ex. ochii). Țineți dușul la o distanță corespunzătoare de corp.
- ⚠ Sistemul de duș poate fi utilizat doar pentru spălarea, menținerea igienei și curățarea corpului.

Instrucțiuni de montare

- Înainte de instalare verificați, dacă produsul prezintă deteriorări de transport. După instalare garanția nu acoperă deteriorările de transport și cele de suprafață.
- Conductele și bateriile trebuie montate, spălate și verificate conform normelor în vigoare.
- Respectați reglementările referitoare la instalare valabile în țara respectivă.
- La montarea produsului de către un personal calificat se va avea grijă ca suprafața de fixare să fie plană pe toată aria de fixare (fără proeminențe ale rosturilor sau îmbinări între plăcile de faianță) și ca structura peretelui să fie corespunzătoare pentru fixarea produsului, să nu prezinte locuri cu rezistență redusă.

Date tehnice

Presiune de funcționare:	max. 0,6 MPa
Presiune de funcționare recomandată 27378XXX / 27337XXX:	0,15 – 0,4 MPa
Presiune de funcționare recomandată 26466XXX / 26467XXX:	0,1 – 0,4 MPa
Presiune de funcționare recomandată 27384XXX / 27385XXX:	0,2 – 0,4 MPa
(1 MPa = 10 bar = 147 PSI)	
Temperatura apei calde:	max. 60°C
Dezinfecție termică:	max. 70°C / 4 min

Produsul este destinat exclusiv pentru apă potabilă.

Descrierea simbolurilor



Nu utilizați silicon cu conținut de acid acetic!

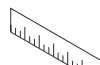

Dimensiuni (vezi pag. 31)



Diagrama de debit

(vezi pag. 31)

- ① Rain
- ② RainAir



Utilizare (vezi pag. 39)

Pentru golirea telefonului de duș amplasați-l pe acesta ușor înclinat după utilizare.



Curățare (vezi pag. 40) și broșura alăturată



Piese de schimb (vezi pag. 42)



Certificat de testare (vezi pag. 48)



Montaj pe perete vezi pag. 34



Montaj pe plafon vezi pag. 36



Υποδείξεις ασφαλείας

- ⚠ Για να αποφύγετε τραυματισμούς κατά τη συναρμολόγηση πρέπει να φοράτε γάντια.
- ⚠ Ο βραχίονας του ντους κεφαλιού έχει μελετηθεί μόνο για να κρατά το ντους κεφαλιού, δεν επιτρέπεται να φορτίζεται με άλλα αντικείμενα!
- ⚠ Παιδιά ή ενήλικες με μειωμένες σωματικές, διανοητικές και/ή αισθητήριες ανεπάρκειες δεν επιτρέπεται να χρησιμοποιούν το προϊόν χωρίς επιτήρηση. Άτομα υπό την επήρεια οινοπνεύματος ή ναρκωτικών δεν επιτρέπεται να χρησιμοποιούν σε καμία περίπτωση το προϊόν.
- ⚠ Η επαφή δέσμης νερού του ντους με ευαίσθητες περιοχές του σώματος (π.χ. μάτια) πρέπει να αποφεύγεται. Διατηρείτε επαρκή απόσταση ανάμεσα στο ντους και το σώμα.
- ⚠ Το προϊόν επιτρέπεται να χρησιμοποιείται μόνο σαν μέσο λουτρού, υγιεινής και καθαρισμού του σώματος.

Οδηγίες συναρμολόγησης

- Πριν τη συναρμολόγηση πρέπει να εξεταστεί το προϊόν για ζημιές μεταφοράς. Μετά την εγκατάσταση δεν αναγνωρίζονται ζημιές από τη μεταφορά ή επιφανειακές ζημιές.
- Οι σωλήνες και η μπαταρία πρέπει να τοποθετηθούν σύμφωνα με τα ισχύοντα πρότυπα, να τεθούν υπό πίεση και να δοκιμαστούν.
- Θα πρέπει να τηρούνται οι οδηγίες εγκατάστασης που ισχύουν σε κάθε κράτος.
- Κατά τη συναρμολόγηση του προϊόντος από ειδικό προσωπικό θα πρέπει να ελέγχεται με ιδιαίτερη προσοχή η επιφάνεια στερέωσης, αν είναι επίπεδη σε όλη της την επιφάνεια (δεν πρέπει να εξέχουν αρμοί ή πλακάκια), αν η υποδομή του τοίχου είναι κατάλληλη για τη στερέωση του προϊόντος και αν παρουσιάζει ασθενή σημεία.

Τεχνικά Χαρακτηριστικά

Λειτουργία πίεσης:	έως 0,6 MPa
Συνιστώμενη λειτουργία πίεσης 27378XXX / 27337XXX:	0,15 – 0,4 MPa
Συνιστώμενη λειτουργία πίεσης 26466XXX / 26467XXX:	0,1 – 0,4 MPa
Συνιστώμενη λειτουργία πίεσης 27384XXX / 27385XXX: (1 MPa = 10 bar = 147 PSI)	0,2 – 0,4 MPa
Θερμοκρασία ζεστού νερού:	έως 60°C
Θερμική απολύμανση:	έως 70°C / 4 min

Το προϊόν έχει σχεδιαστεί αποκλειστικά για πόσιμο νερό!

Περιγραφή συμβόλων



Μην χρησιμοποιείτε σιλικόνη που περιέχει οξικό οξύ!

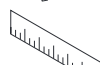

Διαστάσεις (βλ. Σελίδα 31)



Διάγραμμα ροής
(βλ. Σελίδα 31)

- ① Rain
- ② RainAir



Χειρισμός (βλ. Σελίδα 39)

Για να αδειάσει το ντους κεφαλιού τοποθετήστε το μετά τη χρήση λίγο λοξά.



Καθαρισμός (βλ. Σελίδα 40) και
συνημμένο φυλλάδιο



Ανταλλακτικά (βλ. Σελίδα 42)



Σήμα ελέγχου (βλ. Σελίδα 48)



Επιτοίχια συναρμολόγηση βλ. Σελίδα 34



Συναρμολόγηση στην οροφή βλ. Σελίδα 36



Varnostna opozorila

- ⚠ Pri montaži je treba nositi rokavice, da se preprečijo poškodbe zaradi zmečkanja ali urezov.
- ⚠ Nosilna roka naglavne prhe je konstruirana le za nošenje prhe in je ne smete obremeniti z drugimi predmeti!
- ⚠ Otroci kot tudi odrasle osebe z omejenimi telesnimi, duševnimi in/ali senzoričnimi sposobnostmi ne smejo nenadzorovano uporabljati tega izdelka. Osebe, ki so pod vplivom alkohola ali drog, tega izdelka ne smejo uporabljati.
- ⚠ Izogibati se je treba stiku prhalnega curka z občutljivimi deli telesa (npr. očmi). Med telesom in prho mora biti vedno zadosten razmik.
- ⚠ Ta izdelek se sme uporabljati le z namenom umivanja, vzdrževanja higiene in telesne nege.

Navodila za montažo

- Pred montažo je treba izdelek preveriti glede morebitnih transportnih poškodb. Po vgradnji transportne ali površinske poškodbe ne bodo več priznane.
- Cevi in armaturo je treba montirati, izprati in preveriti po veljavnih standardih.
- Upoštevati je treba pravilnike o inštalacijah, ki veljajo v posamezni državi.
- Pri montaži tega proizvoda s strani kvalificiranega strokovnega osebja je treba paziti na to, da je pritrđilna ploskev na celotni površini za pritrđitev gladka (brez izstopajočih fug ali zasekov ploščic), da je struktura stene primerna za montažo proizvoda in ne kaže šibkih mest.

Tehnični podatki

Delovni tlak:	maks. 0,6 MPa
Priporočeni delovni tlak 27378XXX / 27337XXX:	0,15 – 0,4 MPa
Priporočeni delovni tlak 26466XXX / 26467XXX:	0,1 – 0,4 MPa
Priporočeni delovni tlak 27384XXX / 27385XXX: (1 MPa = 10 bar = 147 PSI)	0,2 – 0,4 MPa
Temperatura tople vode:	maks. 60 °C
Termična dezinfekcija:	maks. 70 °C / 4 min

Proizvod je zasnovan izključno za sanitarno vodo!

Opis simbola



Ne smete uporabiti silikona, ki vsebuje osetno kislino!

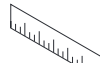

Mere (glejte stran 31)



Diagram pretoka

(glejte stran 31)

- ① Rain
- ② RainAir



Upravljanje (glejte stran 39)

Za praznjenje nadglavne prhe slednjo po uporabi namestite nekoliko poševno.



Čiščenje (glejte stran 40) in priložena brošura



Rezervni deli (glejte stran 42)



Preskusni znak (glejte stran 48)



Montaža na steno glejte stran 34



Montaža na strop glejte stran 36

**Ohutusjuhised**

- ⚠ Kandke paigaldamisel muljumis- ja löikevigastuste vältimiseks kindaid.
- ⚠ Dušipea hoidik on mõeldud ainult dušipea hoidmiseks ja seda ei tohi muude esemetega koormata!
- ⚠ Lapsed, samuti kehaliste, vaimsete või tajupiirangutega täiskasvanud ei tohi dušisüsteemi järelvalveta kasutada. Alkoholi või narkootikumide mõju all olevad isikud ei tohi dušisüsteemi kasutada.
- ⚠ Duši veejoad ei tohi kokku puutuda tundlike kehaosadega (nt silmad). Jätke duši ja keha vahele piisav vahe.
- ⚠ Toodet tohib kasutada ainult pesemis-, hügieeni- ja kehapihustamiseesmärkidel.

Paigaldamisjuhised

- Enne paigaldamist tuleb toodet kontrollida transpordikahjustuste osas. Pärast paigaldamist ei tunnustata enam transpordi- või pinnakahjustuste kaebuseid.
- Voolikute ja segisti paigaldamisel, loputamisel ja kontrollimisel tuleb lähtuda kehtivatest normatiividest.
- Vastavas riigis kehtivaid paigalduseeskirju tuleb järgida.
- Toote paigaldamisel kvalifitseeritud spetsialistide poolt tuleb jälgida, et kinnituspind oleks kogu ulatuses ühtlaselt tasane (mitte ühtki üleseisvat vuuki või kaldus kahhelkivi), seina ülesehitus toote paigaldamiseks sobiv ja ilma nõrkade kohtadeta.

Tehnilised andmed

Töörõhk		maks. 0,6 MPa
Soovitatav töörõhk		
27378XXX / 27337XXX:	0,15 – 0,4 MPa	
Soovitatav töörõhk		
26466XXX / 26467XXX:	0,1 – 0,4 MPa	
Soovitatav töörõhk		
27384XXX / 27385XXX:	0,2 – 0,4 MPa	
(1 MPa = 10 baari = 147 PSI)		
Kuuma vee temperatuur:		maks. 60°C
Termiline desinfektsioon:		maks. 70°C / 4 min

Toode on ette nähtud eranditult joogivee jaoks!

Sümbolite kirjeldus

Ärge kasutage äädikhapet sisaldavat silikooni!



Mõõtude (vt lk 31)



Läbivooludiagramm

(vt lk 31)

- ① Rain
- ② RainAir



Kasutamine (vt lk 39)

Dušipea tühjendamiseks tuleb see pärast kasutamist kergelt kaldu asetada.



Puhastamine (vt lk 40) ja kaasas olev brošüür



Varuosad (vt lk 42)



Kontrollsertifikaat (vt lk 48)



seinale kinnitamine vt lk 34



lakke kinnitamine vt lk 36



Drošības norādes

- ⚠ Montāžas laikā, lai izvairītos no saspiedumiem un iegriezumiem, nepieciešams nēsāt cimdus.
- ⚠ Galvas dušas statīvs paredzēts vienīgi galvas dušas atbalstīšanai, to nedrīkst noslogot ar citiem priekšmetiem!
- ⚠ Bērni, kā arī pieaugušie ar fiziskiem, garīgiem un / vai sensoriskiem ierobežojumiem nedrīkst lietot šo produktu bez uzraudzības. Personas, kas atrodas alkohola vai narkotisko vielu iespaidā, nedrīkst lietot šo dušas sistēmu.
- ⚠ Nepieciešams izvairīties no dušas strūkļas tieša kontakta ar jutīgām ķermeņa daļām (piem., acīm). Nepieciešams ievērot pietiekošu attālumu starp dušu un ķermeni.
- ⚠ Šo produktu drīkst izmantot tikai, lai mazgātos, higiēnai un ķermeņa tīrīšanai.

Norādījumi montāžai

- Pirms montāžas nepieciešams pārbaudīt, vai produktam transportēšanas laikā nav radušies bojājumi. Pēc iebūvēšanas bojājumi, kas radušies transportēšanas laikā, vai virsmas bojājumi netiek atzīti.
- Cauruļvadi un armatūra ir jāuzstāda, jāizskalo un jāpārbauda saskaņā ar spēkā esošajiem standartiem.
- Jāievēro attiecīgās valstīs spēkā esošās montāžas prasības.
- Kvalificētiem speciālistiem, montējot produktu, jāpiegriež vērība tam, lai piestiprināšanas virsma visā piestiprināšanas zonā ir gluda (nav fūgu vai flīžu iecirtumu), sienas uzbūve ir piemērota produkta montāžai un tajā nav nestabilu vietu.

Tehniskie dati

Darba spiediens:	maks. 0,6 MPa
Ieteicamais darba spiediens 27378XXX / 27337XXX:	0,15 – 0,4 MPa
Ieteicamais darba spiediens 26466XXX / 26467XXX:	0,1 – 0,4 MPa
Ieteicamais darba spiediens 27384XXX / 27385XXX: (1 MPa = 10 bar = 147 PSI)	0,2 – 0,4 MPa
Karstā ūdens temperatūra:	maks. 60°C
Termiskā dezinfekcija :	maks. 70°C / 4 min

Izstrādājums ir paredzēts tikai dzeramajam ūdenim!

Simbolu nozīme



Neizmantojot silikonu, kas satur etiķskābi!



Izmērus (skat. lpp. 31)



Caurplūdes diagramma

(skat. lpp. 31)

① Rain

② RainAir



Lietošana (skat. lpp. 39)

Lai no augšējās dušas iztektu ūdens, pēc lietošanas, nedaudz noslieciet to.



Tīrīšana (skat. lpp. 40) un klāt pievienotais buklets



Rezerves daļas (skat. lpp. 42)



Pārbaudes zīme (skat. lpp. 48)



Montāža pie sienas skat. lpp. 34



Montāža pie griestiem skat. lpp. 36



Sigurnosne napomene

- ⚠ Prilikom montaže se radi sprečavanja prignječenja i posekotina moraju nositi rukavice.
- ⚠ Nosač tuša iznad glave je dimenzioniran samo za držanje datog tuša i ne sme se opterećivati drugim predmetima!
- ⚠ Deca, kao i telesno, mentalno i/ili senzorno hendikepirane odrasle osobe ne smeju da koriste proizvod bez nadzora. Osobe koje su pod uticajem alkohola ili droga ne smeju da koriste proizvod.
- ⚠ Mora se izbegavati kontakt mlaza iz tuša sa osetljivim delovima tela (npr. očima). Telo korisnika mora biti na dovoljnom odstojanju od tuša.
- ⚠ Proizvod sme da se koristi samo za kupanje, tuširanje i ličnu higijenu.

Instrukcije za montažu

- Pre montaže se mora proveriti da li je proizvod oštećen pri transportu. Nakon ugradnje se ne priznaju nikakve reklamacije koje se odnose na površinska i transportna oštećenja.
- Vodovi i armatura moraju biti postavljeni, isprani i testirani prema važećim normama.
- Treba se pridržavati propisa koji u određenim zemljama važe za instalacije.
- Kada proizvod montira kvalifikovano stručno osoblje treba paziti da čitava površina na koju se učvršćuje bude ravna (bez istaknutih fuga ili krivljenja pločica), da je zidna konstrukcija primerena montaži proizvoda i da nema slabih mesta.

Tehnički podaci

Radni pritisak:	maks. 0,6 MPa
Preporučeni radni pritisak 27378XXX / 27337XXX:	0,15 – 0,4 MPa
Preporučeni radni pritisak 26466XXX / 26467XXX:	0,1 – 0,4 MPa
Preporučeni radni pritisak 27384XXX / 27385XXX: (1 MPa = 10 bar = 147 PSI)	0,2 – 0,4 MPa
Temperatura vruće vode:	maks. 60°C
Termička dezinfekcija:	maks. 70°C / 4 min

Proizvod je koncipiran isključivo za pijaću vodu!

Opis simbola



Nemojte koristiti silikon koji sadrži sirćetnu kiselinu!



Mere (vidi stranu 31)



Dijagram protoka

(vidi stranu 31)

- ① Rain
- ② RainAir



Rukovanje (vidi stranu 39)

Nakon korišćenja neznatno nagnite tuš iznad glave u stranu da biste ga ispraznili.



Čišćenje (vidi stranu 40) i priložena brošura



Rezervni delovi (vidi stranu 42)



Ispitni znak (vidi stranu 48)



Montaža na zid vidi stranu 34



Montaža na plafon vidi stranu 36



Sikkerhetshenvisninger

- ⚠ Bruk hansker under montasjen for å unngå klem- og kuttskader.
- ⚠ Armen til hodedusjen er kun laget for å holde hodedusjen. Den må ikke belastes med andre gjenstander!
- ⚠ Barn og voksne med fysiske og psykiske og/eller sensoriske handicap skal ikke bruke dusjsystemet uten oppsyn. Personer som er påvirket av alkohol eller narkotika skal ikke bruke dusjsystemet.
- ⚠ Dusjstrålen skal ikke komme i kontakt med ømfintlige kroppsdeler (f.eks. øynene). Overhold en tilstrekkelig avstand mellom dusjen og kroppen.
- ⚠ Dusjsystemet skal kun brukes for bade-, hygiene- og kroppshygiene.

Montagehenvisninger

- Før montasjen skal produktet sjekkes for transportskader. Etter monteringen aksepteres ikke noen transport eller overflateskader.
- Ledningene og armaturen skal monteres, spyles og sjekkes iht. de gyldige normer.
- Gjeldende retningslinjer for rørleggerarbeid i de enkelte land skal følges.
- Under monteringen av produktet gjort av kvalifisert fagpersonell, skal man påse at monteringsoverflaten på hele festeområdet er plant (ingen utstikkende fuger eller flisekanter), at veggoppbyggingen egner seg for produktmontasjen og ikke viser svake punkter.

Tekniske data

Driftstrykk	maks. 0,6 MPa
Anbefalt driftstrykk 27378XXX / 27337XXX:	0,15 – 0,4 MPa
Anbefalt driftstrykk 26466XXX / 26467XXX:	0,1 – 0,4 MPa
Anbefalt driftstrykk 27384XXX / 27385XXX: (1 MPa = 10 bar = 147 PSI)	0,2 – 0,4 MPa
Varmtvannstemperatur	maks. 60°C
Termisk desinfisering:	maks. 70°C / 4 min

Produktet er utelukkende designet for drikkevann!

Symbolbeskrivelse



Ikke bruk silikon som inneholder eddiksyre!

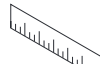

Mål (se side 31)



Gjennomstrømningsdiagram

(se side 31)

① Rain

② RainAir



Betjening (se side 39)

Sett dusjhodet litt på skrå for å tømme det etter bruk.



Rengjøring (se side 40) og vedlagt brosjyre

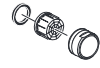

Serviceledere (se side 42)



Prøvemerket (se side 48)



Veggmontasje se side 34



Takmontasje se side 36



Указания за безопасност

- При монтажа трябва да се носят ръкавици, за да се избегнат наранявания поради притискане или порязване.
- Рамото на разпръсквателя за главата е разработена само, за да държи разпръсквателя за главата, то не бива да се натоварва с други предмети!
- Не е позволено деца, както и възрастни с физически, умствени и / или сензорни ограничения да използват продукта без надзор. Не е позволено използването на системата на продукта от лица, употребили алкохол или дрога.
- Трябва да се избягва контакта на струите на разпръсквателя с чувствителни части на тялото (напр. очите). Между разпръсквателя и тялото трябва да се спазва достатъчно разстояние.
- Позволено е използването на продукта само за къпане, хигиена и цели на почистване на тялото.

Указания за монтаж

- Преди монтажа продуктът трябва да се провери за транспортни щети. След монтажа не се признават транспортни или повърхностни щети.
- Тръбопроводите и арматурата трябва да се монтират, промият и проверят в съответствие с валидните норми.
- Трябва да бъдат спазвани валидните в съответните страни предписания за инсталиране.
- При монтаж на продукта от квалифицирани специалисти да се внимава за това, закрепващата повърхност в целия диапазон на закрепването да бъде равна (без изпъкнали фуги или изместване на плочки), конструкцията на стената да е подходяща за монтаж на продукта и да няма слаби места.

Технически данни

Работно налягане:	макс. 0,6 МПа
Препоръчително работно налягане 27378XXX / 27337XXX:	0,15 – 0,4 МПа
Препоръчително работно налягане 26466XXX / 26467XXX:	0,1 – 0,4 МПа
Препоръчително работно налягане 27384XXX / 27385XXX:	0,2 – 0,4 МПа
(1 МПа = 10 bar = 147 PSI)	
Температура на горещата вода:	макс. 60°C
Термична дезинфекция:	макс. 70°C / 4 мин

Продуктът е разработен само за питейна вода!

Описание на символите



Не използвайте силикон, съдържащ оцетна киселина!

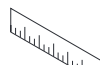

Размери (вижте стр. 31)



Диаграма на потока

(вижте стр. 31)

① Rain

② RainAir



Обслужване (вижте стр. 39)

За изпразване на разпръсквателя на главата след употреба го поставете леко наклонен.



Почистване (вижте стр. 40) и приложена брошура

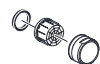

Сервизни части (вижте стр. 42)



Контролен знак (вижте стр. 48)



Монтаж на стена вижте стр. 34



Монтаж на таван вижте стр. 36



Udhëzime sigurie

- ⚠ Për të evituar lëndimet e pickimeve ose të prerjeve gjatë procesit të montimit duhet që të vishni doreza.
- ⚠ Mbjajtësja e kokës së dushit është projektuar vetëm për mbajtjen e kokës së dushit dhe nuk duhet që të rëndohet me objekte të tjera!
- ⚠ Fëmijët dhe të rriturit me aftësi të kufizuara fizike, mendore dhe/ose ndijuese nuk duhet ta përdorin produktin pa qenë nën mbikëqyrje. Personat që janë nën ndikimin e drogave ose të alkoolit nuk duhet ta përdorin produktin.
- ⚠ Kontakti i valëve të dushit me pjesët e ndjeshme të trupit (p.sh. me sytë) duhet që të shmanget. Midis dushit dhe trupit duhet që të mbahet një distancë e mjaftueshme.
- ⚠ Produkti duhet të përdoret vetëm qëllimet e banjave, të higjienës dhe të larjes së trupit.

Udhëzime për montimin

- Përpara montimit duhet që produkti të kontrollohet për dëmtime nga transporti. Pas instalimit nuk do të njihet asnjë dëmtim nga transporti ose dëmtim i sipërfaqes.
- Tubacionet dhe rubinetet duhet që të montohen, të shpëlohen dhe të kontrollohen sipas standardeve në fuqi
- Duhet të respektohen linjat udhëzuese të instalimit, të vlefshme për vendet respektive.
- Gjatë montimit të produktit nga teknikët e specializuar duhet mbajtur parasysh që sipërfaqja e montimit gjendet brenda zonës së përgjithshme të planit të montimit (nuk ka vendbashkime të dala ose mospërputhje të pllakave), që struktura e murit është e përshtatshme për montimin e produktit dhe që nuk paraqet asnjë pikë të dobët.

Të dhëna teknike

Presioni gjatë punës	maks. 0,6 MPa
Presioni i rekomanduar 27378XXX / 27337XXX:	0,15 – 0,4 MPa
Presioni i rekomanduar 26466XXX / 26467XXX:	0,1 – 0,4 MPa
Presioni i rekomanduar 27384XXX / 27385XXX: (1 MPa = 10 bar = 147 PSI)	0,2 – 0,4 MPa
Temperatura e ujit të ngrohtë	maks. 60°C
Dezinfektim Termik:	maks. 70°C / 4 min

Produkti është projektuar ekskluzivisht për ujë të pijshëm!

Përshkrimi i simbolit



Mos përdorni silikon që në përbërje ka acid acetik.



Përmasat (shih faqen 31)



Diagrami i qarkullimit

(shih faqen 31)

① Rain

② RainAir



Përdorimi (shih faqen 39)

Për të zbrazur kreun e dushit/rubinetes, pas përdorimit vendoseni lehtë anash.



Pastrimi (shih faqen 40) dhe

broshura bashkëngjitur



Pjesët e servisit (shih faqen 42)



Shenja e kontrollit (shih faqen 48)



Montimi në mur shih faqen 34



Montimi në tavan shih faqen 36



المواصفات الفنية

ضغط التشغيل: الحد الأقصى 0,6 ميجاباسكال
 ضغط التشغيل الموصى به
 27378XXX / 27337XXX : MPa 0,4 – 0,15
 ضغط التشغيل الموصى به
 26466XXX / 26467XXX : MPa 0,4 – 0,1
 ضغط التشغيل الموصى به
 27384XXX / 27385XXX : MPa 0,4 – 0,2
 (1 ميجاباسكال = 10 بار = 147 PSI)
 الحد الأقصى 60°C درجة حرارة الماء الساخن:
 الحد الأقصى 70°C / 4 الدقيقة تعقيم حراري:
 المنتج مخصص فقط لماء الشرب!

تنبيهات الأمان

- ⚠ يجب إرتداء قفازات لليد أثناء التركيب لتجنب حدوث أخطار الإنحشار أو الجروح.
- ⚠ وتطبيق ذراع دش الرأس هي فقط الإمساك بدش الرأس، ولذلك يجب عدم التحميل عليه بأشياء أخرى.
- ⚠ لا يسمح لأي أطفال أو أفراد بالغين يعانون من إعاقات بدنية أو ذهنية أو حسية أو يعانون من جميع هذه الإعاقات باستخدام المنتج إلا تحت إشراف آخرين. كما أنه لا يسمح لأي شخص تحت تأثير تناول الكحول أو المخدرات باستخدام نظام الدش.
- ⚠ يجب تجنب حدوث إتصال مباشر بين الماء الخارج من رأس الدش وبين أجزاء الجسم الحساسة (مثل العينين). يجب وجود مسافة كافية بين رأس الدش والجسم.
- ⚠ لا يجب استخدام نظام الدش إلا في أغراض الاستحمام والأغراض الصحية وأغراض تنظيف الجسم.

تعليمات التركيب

- قبل القيام بعملية التركيب، يجب فحص المنتج للتأكد من خلوه من أية تلفيات ناتجة عن النقل. بعد القيام بعملية التركيب، لن يتم الاعتراف بوجود أية تلفيات سطحية أو تلفيات ناتجة عن عملية النقل.
- يجب تركيب وغسيل واختبار التوصيلات وخلطات المياه طبقاً للمعايير السارية.
- يجب مراعاة القواعد الخاصة بالتركيب وأعمال السباكة وفقاً للوائح الخاصة بكل بلد.
- عند التركيب بواسطة عمال تركيب متخصصين يجب الانتباه إلى أن مساحة التثبيت في مكان التركيب بوجه عام مسطحة (لا توجد روابط أو فروق للربط بين البلاطات). لذا يجب التأكد من أن الحائط الذي سيتم تركيب المنتج عليه صالح لذلك وأنه لا يوجد به نقاط ضعف.

وصف الرمز

هام! لا تستخدم السليكون الذي يحتوي على أحماض!



أبعاد (راجع صفحة 31)



رسم للصرف

(راجع صفحة 31)



Rain ①

RainAir ②

التشغيل (راجع صفحة 39)



قم بإمالة رأس الدوش قليلاً بعد الاستخدام حتى تقوم بتفريغها.

التنظيف (راجع صفحة 40) والكتيب المرفق



قطع الغيار (راجع صفحة 42)



شهادة اختبار (راجع صفحة 48)



تركيب على الحائط راجع صفحة 34



تركيب على السقف راجع صفحة 36



Raindance Select 26466000 / 26466400

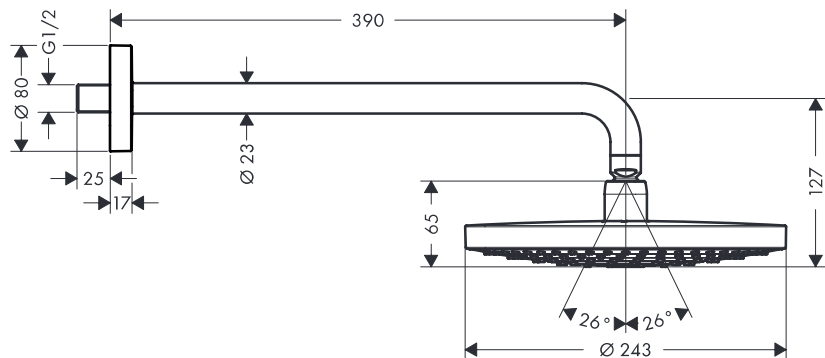

Raindance Select 26467000 / 26467400

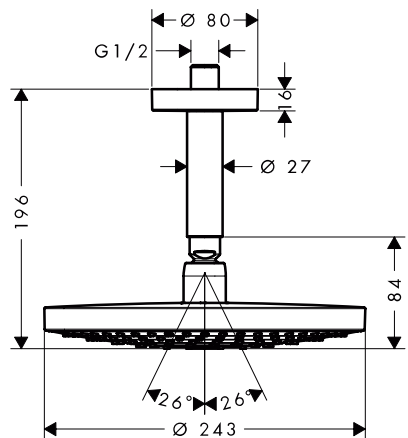

Raindance Select
26466000 / 26466400
26467000 / 26467400

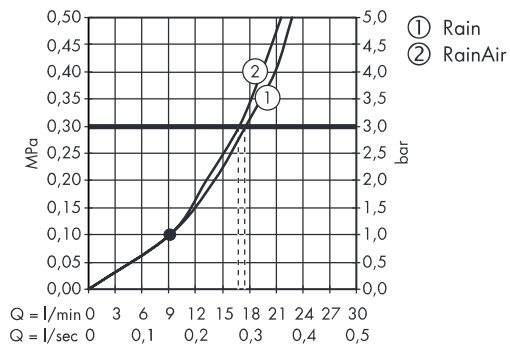



Raindance Select 27378000 / 27378400

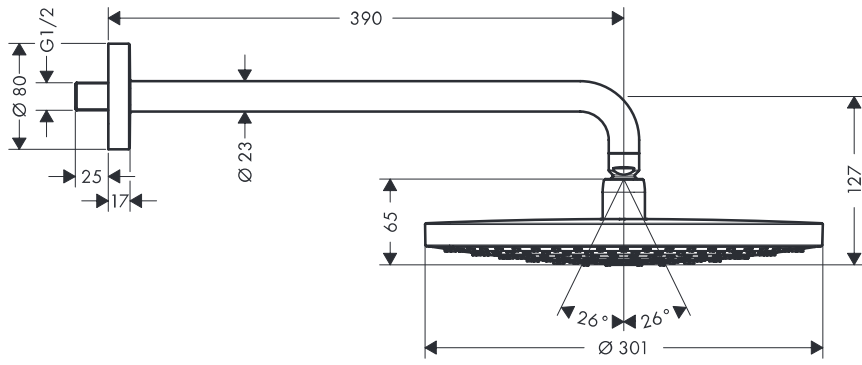

Raindance Select 27337000 / 27337400

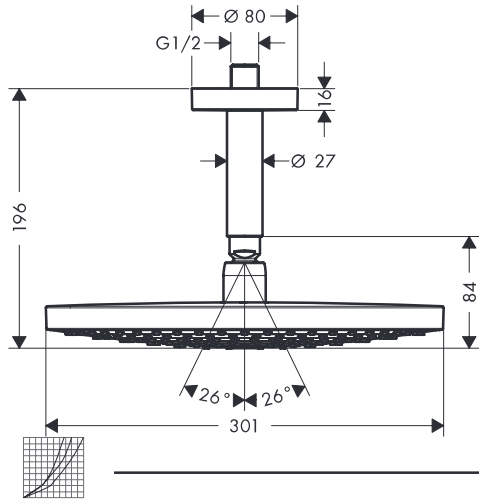

Raindance Select
27378000 / 27378400
27337000 / 27337400

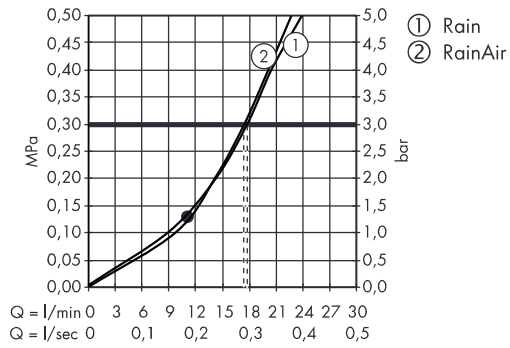

Raindance Select 27385000 / 27385400

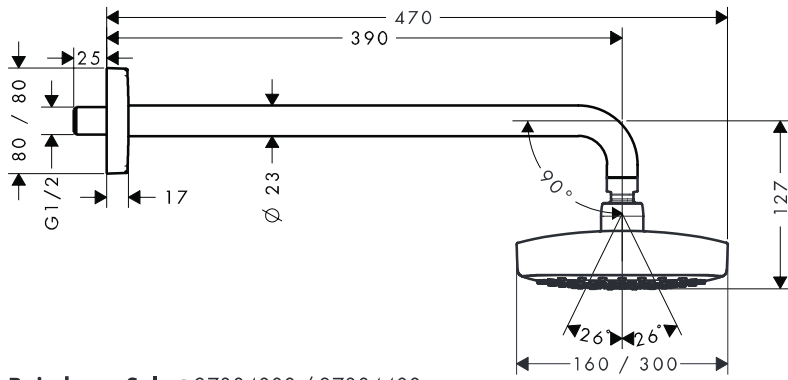

Raindance Select 27384000 / 27384400

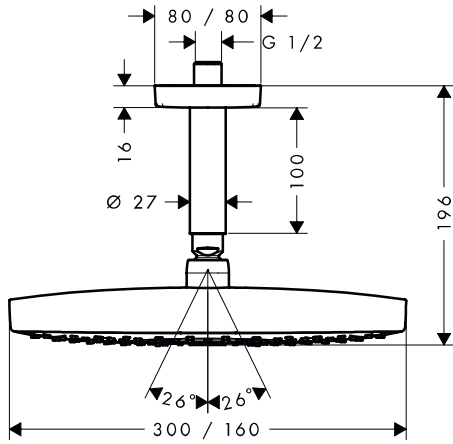

Raindance Select
27384000 / 27384400
27385000 / 27385400

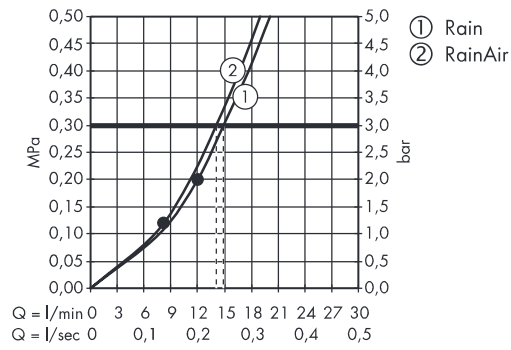

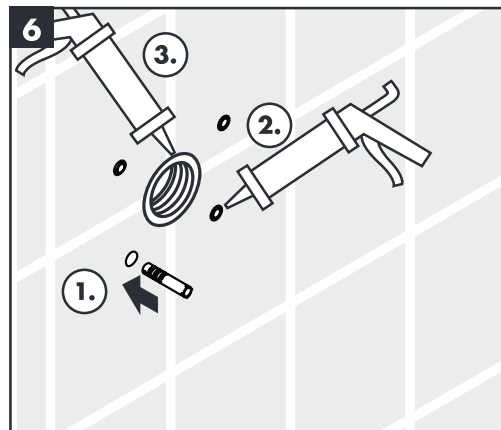
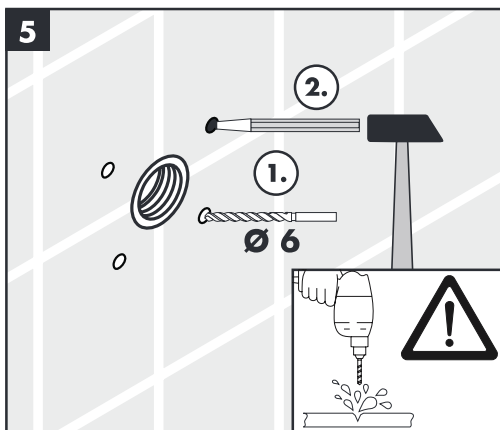
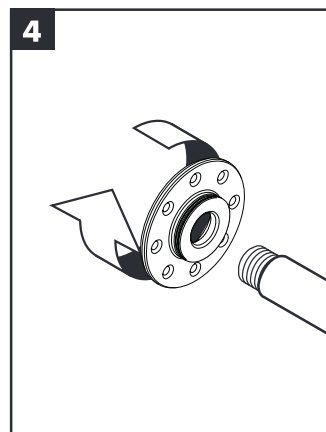
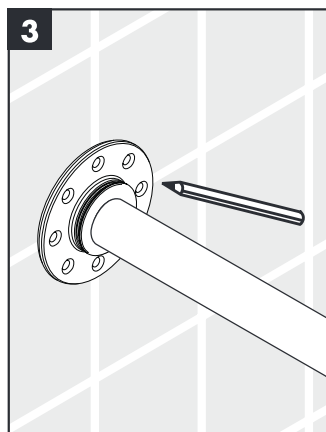
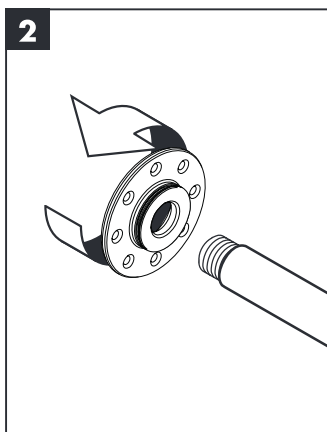
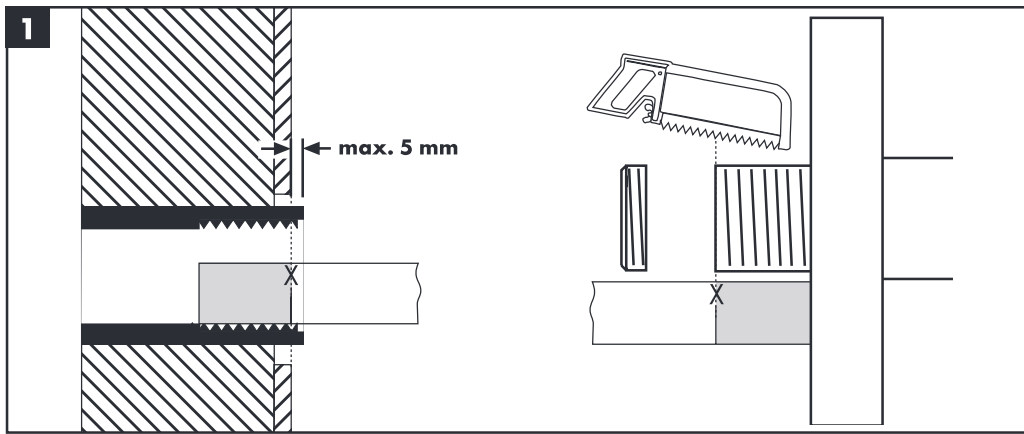

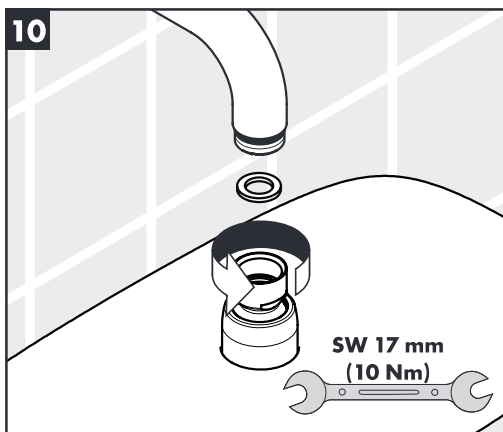
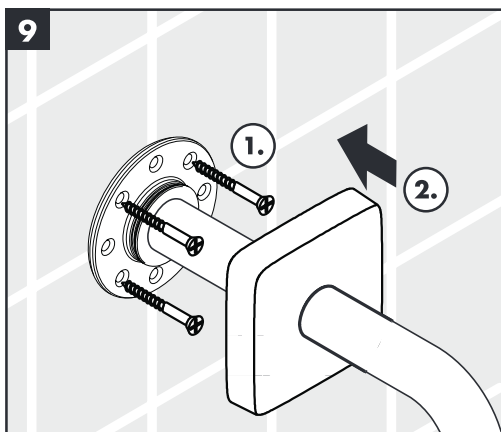
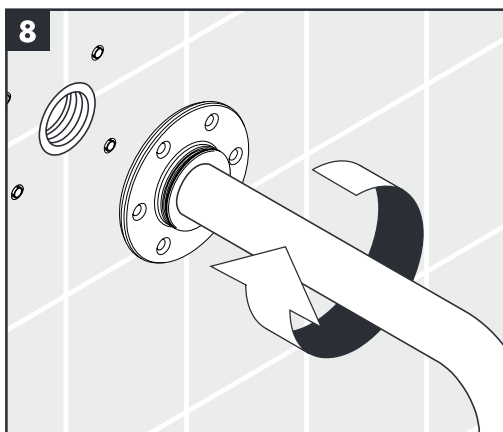
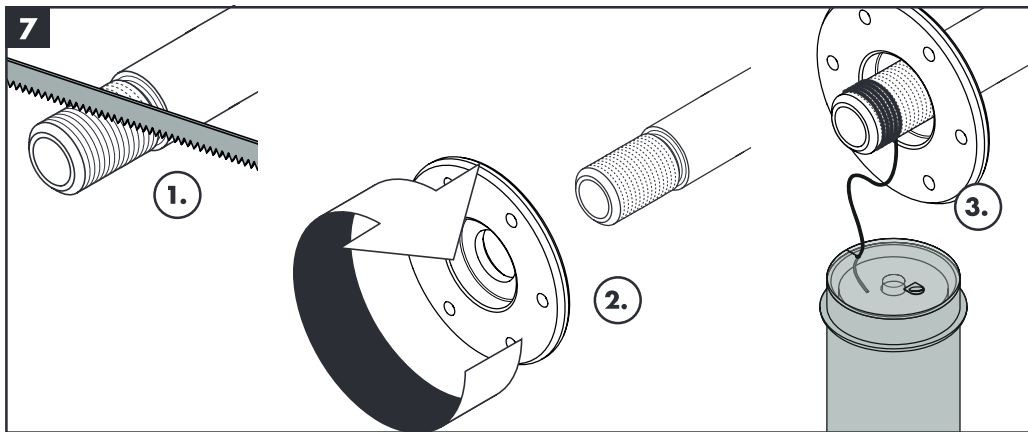

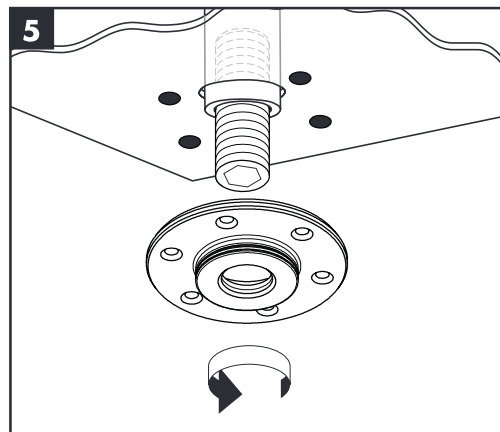
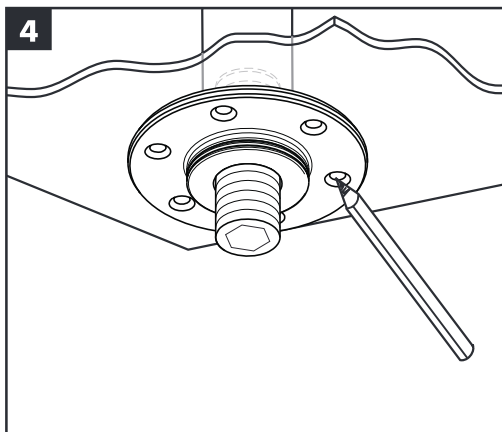
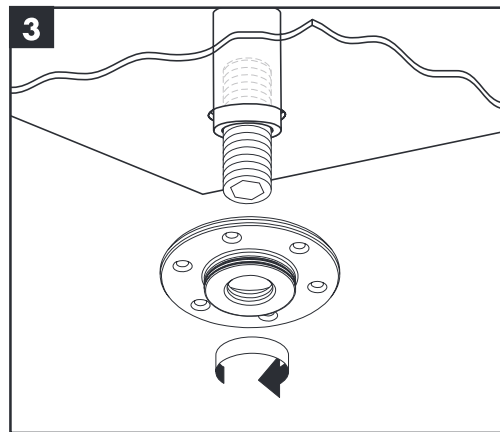
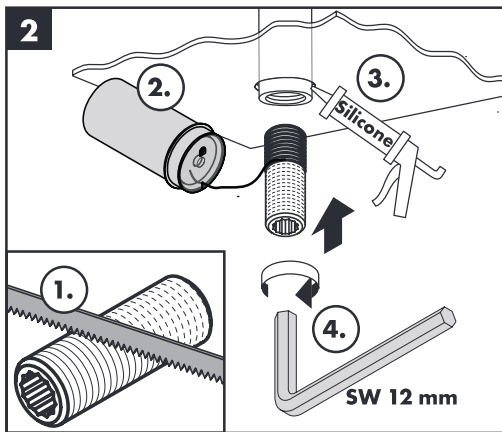
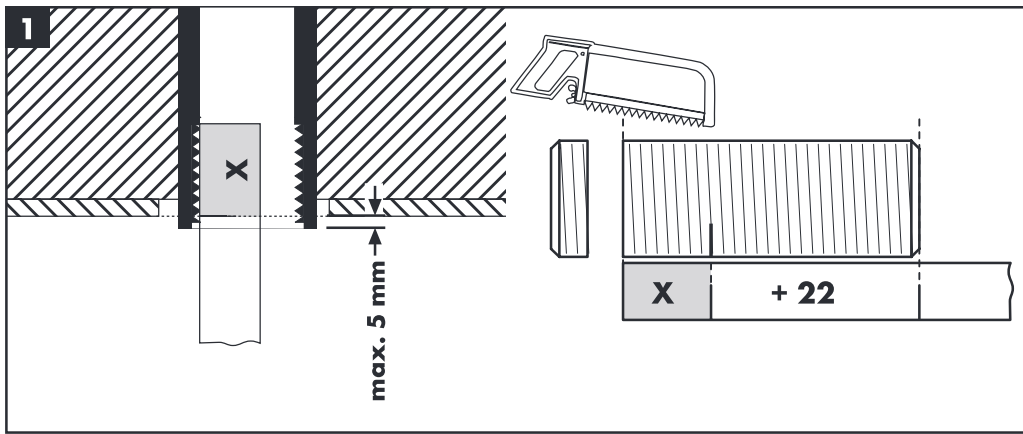

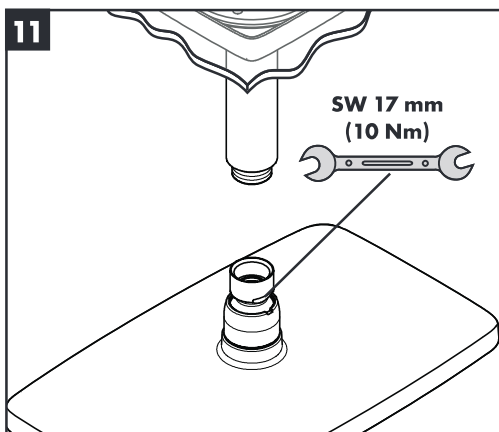
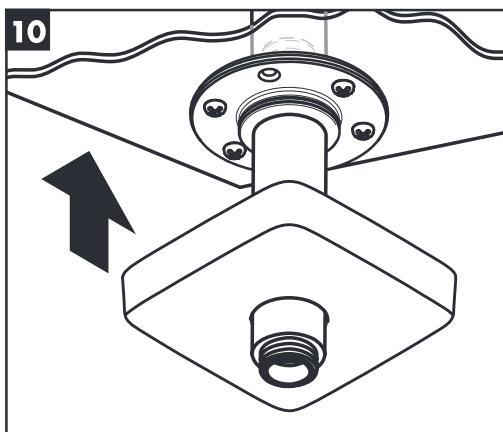
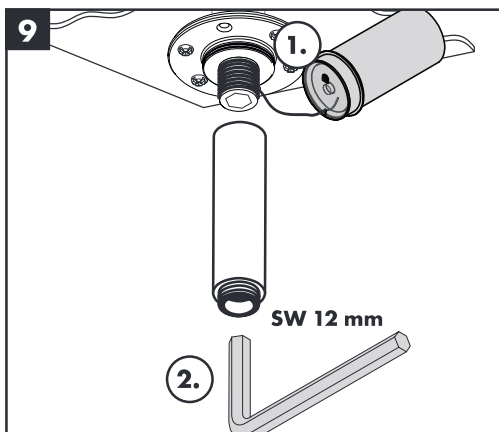
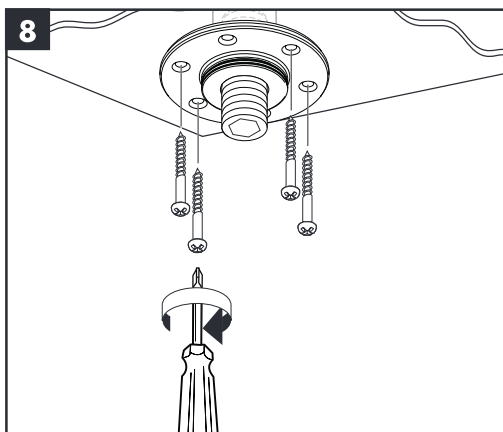
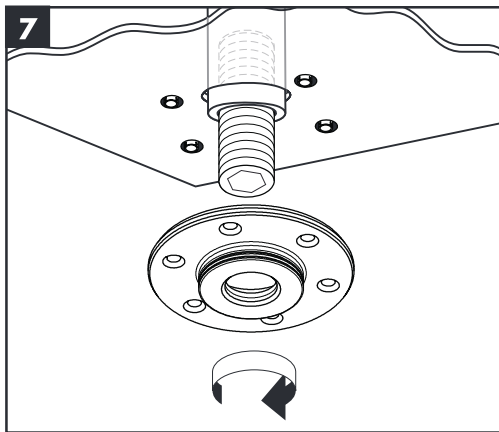
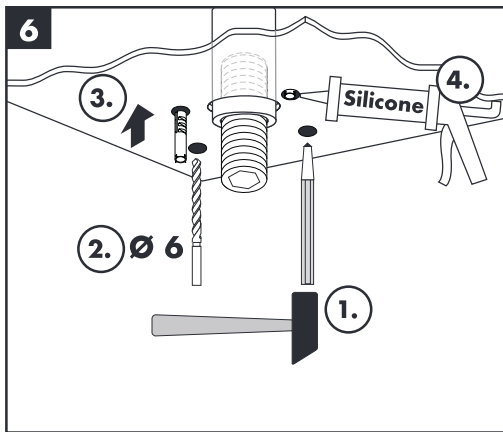



Raindance
27479000

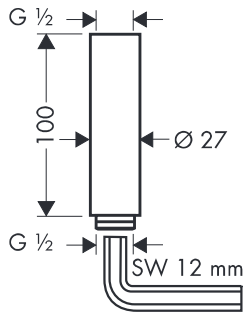

Verlängerung 100 mm
jeu de rallonge 100 mm
extension 100 mm
Prolunga 100 mm
Prolongación 100 mm
Verlengstuk 100 mm
Forlængersæt 100 mm
Crescente 100 mm
Przedłużka 100 mm
prodloužení 100 mm
Predĺženie 100 mm
加长件 100 mm
Удлинение 100 мм
Hosszabbítás 100 mm
Pidennys 100 mm

Förlängning 100 mm
Ilgiklis 100 mm
Produljenje 100 mm
Uzatma 100 mm
Prelungitor 100 mm
Σωλήνας επιμήκυνσης 100 mm
مطاطة 100 مم
Podaljšek 100 mm
Pikendus 100 mm
Pagarinājums 100 mm
Produžetak 100 mm
Forlengelse 100 mm
Удължител 100 мм
Zgiatësi 100 mm

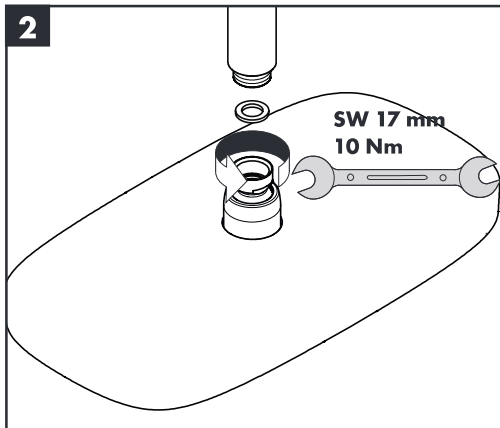
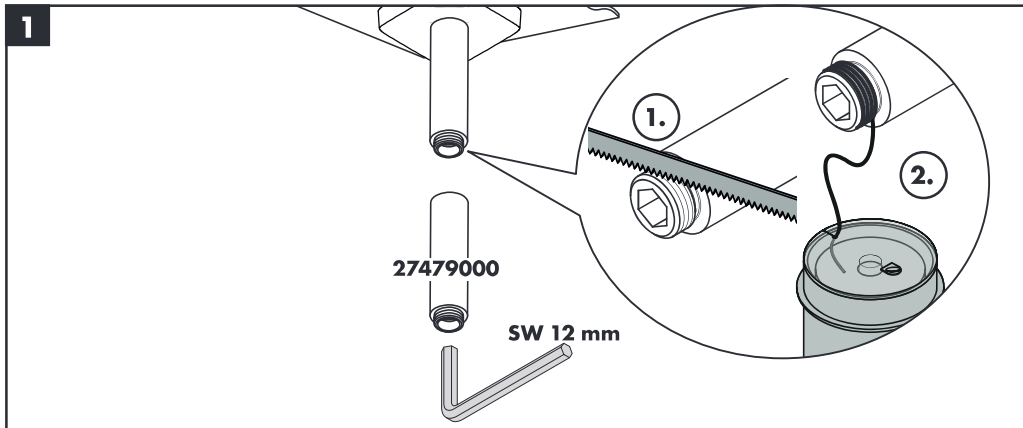

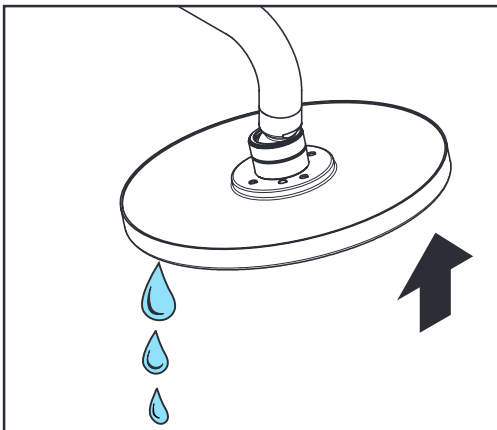
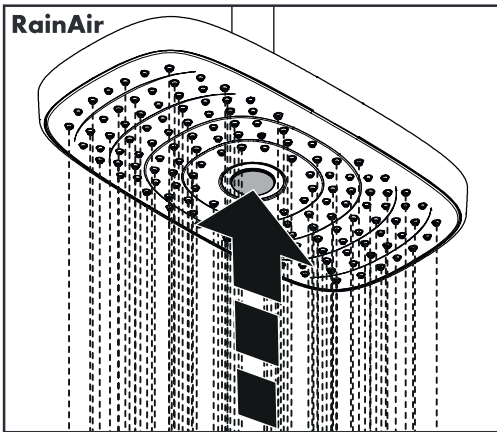
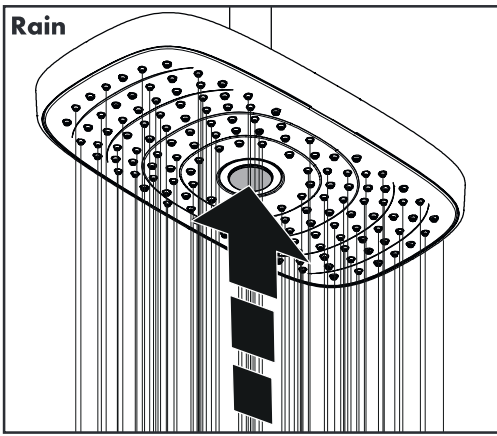

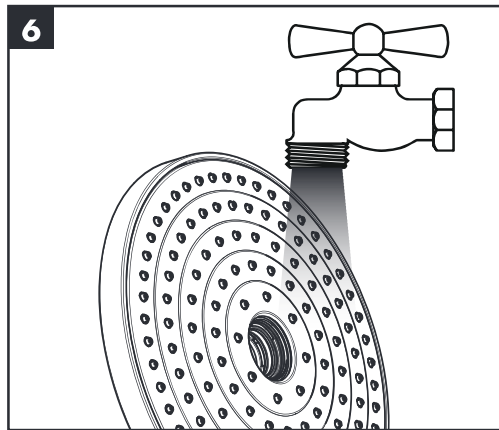
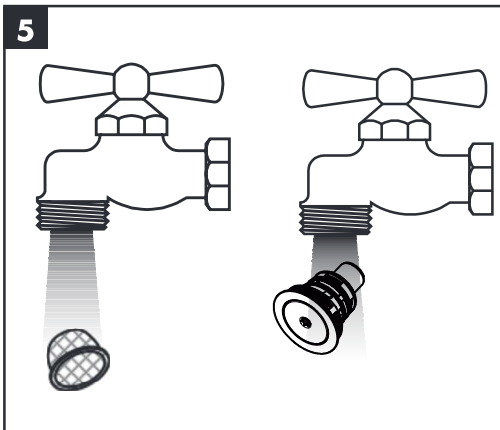
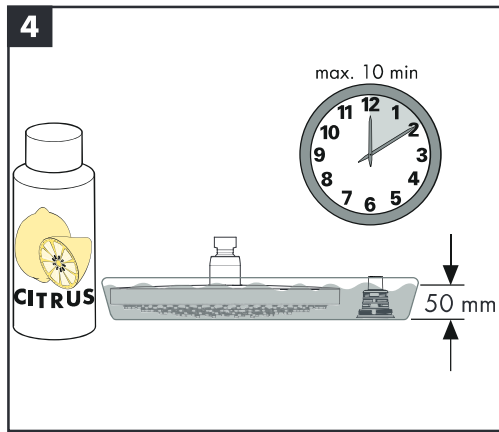
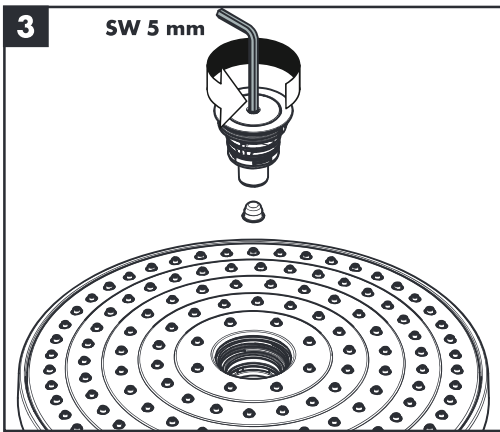
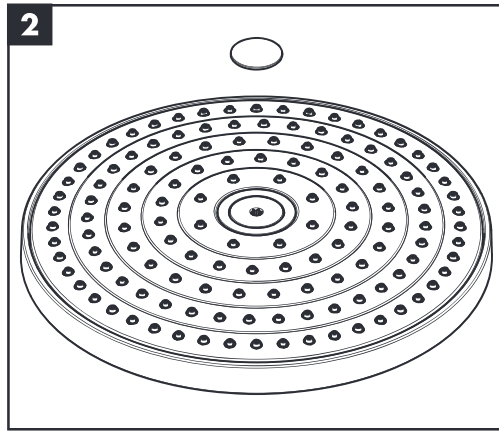
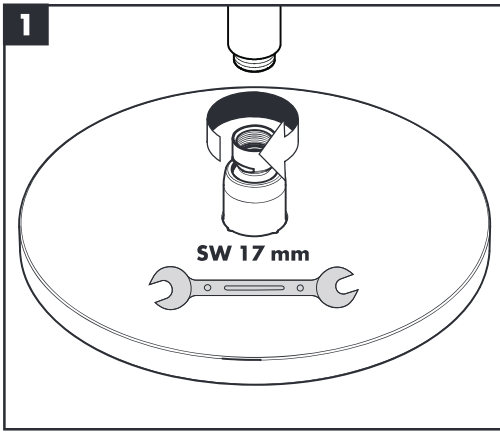

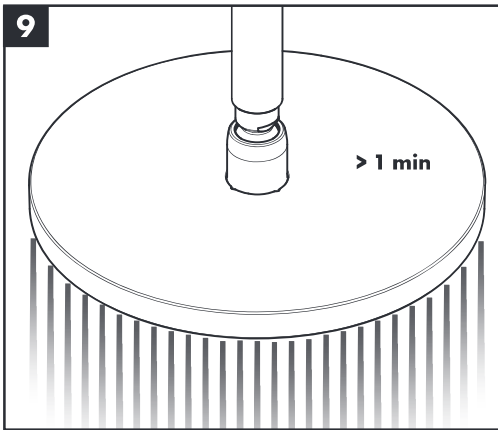
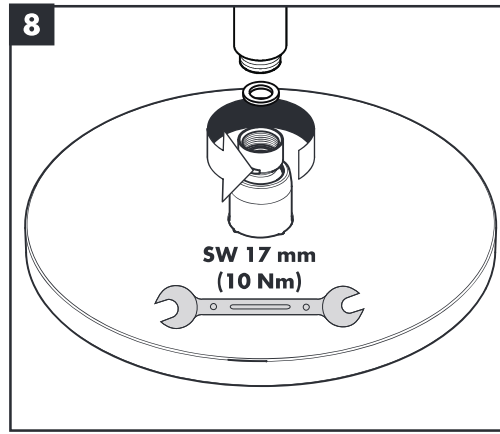
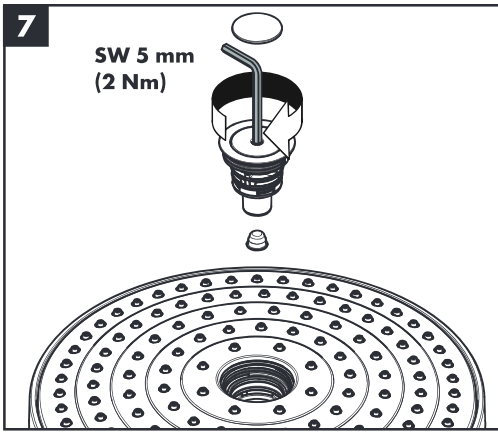



Raindance Select

26466000 / 26466400
27378000 / 27378400

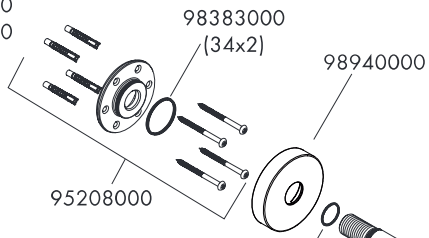

Raindance Select

26467000 / 26467400
27337000 / 27337400

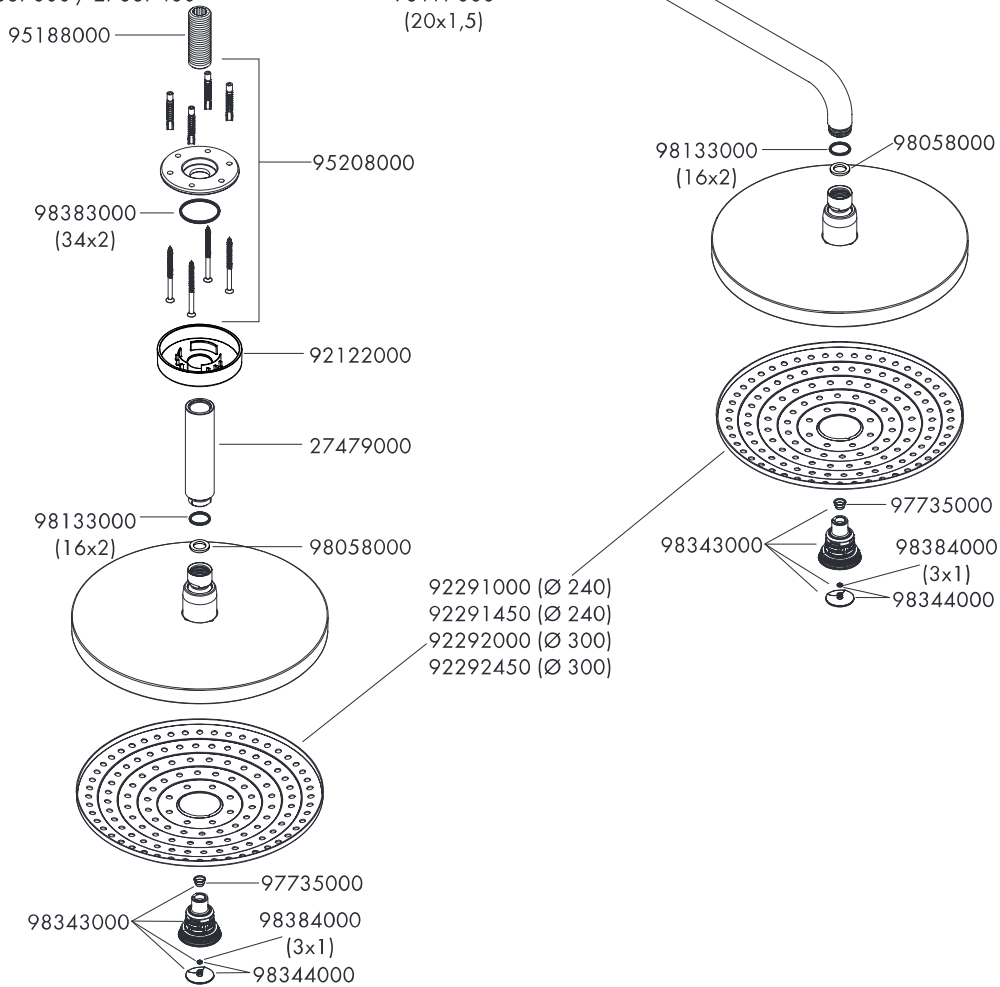



Raindance Select

27385000 / 27385400

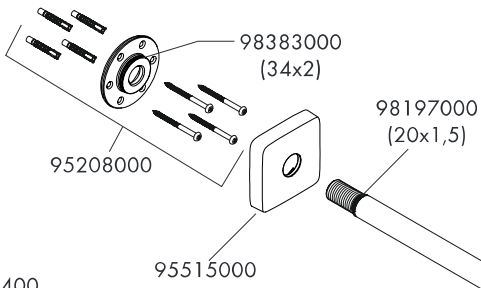

Raindance Select

27384000 / 27384400

