



Biztonsági utasítások

- ⚠ A szerelésnél a zúzódások és vágási sérülések elkerülése érdekében kesztyűt kell viselni.
- ⚠ A terméket csak fürdéshez, mosakodáshoz, és egészségügyi tisztálkodáshoz szabad használni.
- ⚠ A hidegvíz- és a melegvíz-csatlakozások közötti nagy nyomáskülönbséget kikell egyenlíteni!

Szerelési utasítások

- A szerelés előtt ellenőrizni kell, hogy a terméknek nincs-e szállítási sérülése. Beépítés után a szállítási- vagy felületi sérüléseket nem ismerik el.
- A vezetékeket és a csaptelepet az érvényes szabványoknak megfelelően kell felszerelni, öblíteni és ellenőrizni
- Az egyes országokban érvényes installációs irányelveket be kell tartani.

Műszaki adatok

Üzemi nyomás:	max. 1 MPa
Ajánlott üzemi nyomás:	0,1 - 0,5 MPa
Nyomáspróba:	1,6 MPa
(1 MPa = 10 bar = 147 PSI)	
Forróvíz hőmérséklet:	max. 70 °C
Forróvíz javasolt hőmérséklete:	65 °C
Termikus fertőtlenítés:	max. 70 °C / 4 perc

A terméket kizárólag ivóvízhez tervezték!

Szimbólumok leírása



Ne használjon ecetsavtartalmú szilikonf!



Beállítás (lásd a oldalon 33)

A meleg víz korlátozás beállítása. Átfolyós vízmelegítőknél meleg víz korlátozó használata nem ajánlott.



Használat (lásd a oldalon 34)



Méretet (lásd a oldalon 35)



Átfolyási diagramm

(lásd a oldalon 37)

szabad átfolyás

- ① Zuhany lefolyója
- ② Kád lefolyója



Tartozékok (lásd a oldalon 38)

XXX = Színkódolás
000 = króm
090 = króm/arany-hatású
400 = fehér/króm
950 = brushed brass



Tisztítás (lásd a mellékelt brosúrát)



Vizsgajel (lásd a oldalon 37)

Hiba	Ok	Megoldás
Nehezen nyitható a csap.	- A kerámiabetét meghibásodott, elvztkövesedett.	- A kerámiabetétet ki kell cserélni.
Csöpög a csap.	- A kerámiabetét meghibásodott.	- A kerámiabetétet ki kell cserélni.
Túl alacsony melegvíz hőmérséklet, nincs hidegvíz. A hidegvíz kiválasztásakor beindul az átfolyós melegítő.	- A melegvíz szabályozó rosszul van beállítva.	- A melegvíz szabályozót újra be kell állítani.
Az átállítás nem működik	- Kereszfolyás	- A kerámiabetétet ki kell cserélni.
	- Lerakódások	- Váltószelepet tisztítani / O-gyűrűket zsírozni
	- Túl kicsi víznyomás	- Növelje a víznyomást
	- A kádváltó szelep hibás	- Az átállító cseréje



Szerelés lásd a oldalon 31

**Turvallisuusohjeet**

- Asennuksessa on käytettävä käsineitä puristumien ja viiltojen aiheuttamien tapaturmien estämiseksi.
- Tuotetta saa käyttää ainoastaan kylpy-, hygieni- ja puhdistustarkoituksiin.
- Suuret paine-erot kylmä- ja kuumavesiliitäntöjen välillä on tasattava.

Asennusohjeet

- Ennen asennusta on tarkastettava tuotteen mahdolliset kuljetusvahingot. Asennuksen jälkeen kuljetus- ja pintavaurioita ei hyväksytä.
- Putket ja hana on asennettava, huuhdeltava ja tarkastettava voimassa olevien standardien mukaisesti.
- Jokaisessa maassa on noudatettava siellä päteviä asennusohjeita.

Tekniset tiedot

Käyttöpaine:	maks. 1 MPa
Suosittelut käyttöpaine:	0,1 - 0,5 MPa
Koestuspaine:	1,6 MPa
(1 MPa = 10 bar = 147 PSI)	
Kuuman veden lämpötila:	maks. 70 °C
Kuuman veden suosituslämpötila:	65 °C
Lämpödesinfektio:	maks. 70 °C / 4 min

Tuote on suunniteltu käytettäväksi ainoastaan juomaveden kanssa!

Merkin kuvaus

Älä käytä etikkahappopitoista silikonial

**Säätö** (katso sivu 33)

Lämpötilan rajoittimen säätäminen. Emme suosittele käyttämään lämpötilan rajoitinta vedenlämmittimen (läpivirtauskuumennin) yhteydessä.

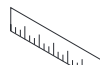
**Käyttö** (katso sivu 34)**Mitat** (katso sivu 35)**Virtausdiagrammi** (katso sivu 37)

vapaa läpivirtaus

- Suihkun lähtö
- Ammeen lähtö

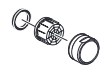
**Varaosat** (katso sivu 38)

XXX = Värikoodaus
000 = kromi
090 = kromi/kultaoptiikka
400 = valkoinen/kromi
950 = brushed brass

**Puhdistus** (katso oheinen esite)**Koestusmerkki** (katso sivu 37)

Häiriö	Syy	Toimenpide
Hana on raskaskäyttöinen	- Patruuna rikki, kalkkikerrostumia	- Vaihda patruuna
Hanasta tippuu vettä	- Patruuna rikki	- Vaihda patruuna
Lämminveden lämpötila liian alhainen, ei kylmää vettä. Läpivirtauskuumennin käynnistyy kylmää vettä otettaessa.	- Lämminveden rajoitin väärin säädetty	- Säädä lämminveden rajoitin
	- Ristiinvirtaus	- Vaihda patruuna
Valitsin ei toimi	- kerrostumia	- Vaihtimen puhdistus / O-renkaiden rasvaus
	- Liian matala vedenpaine	- Lisää vedenpainetta
	- Valitsin rikki	- Vaihda valitsin

**Asennus katso sivu 31**



⚠ Säkerhetsanvisningar

- ⚠ Handskar ska bäras under monteringsarbetet så att man kan undvika kläm- och skärskadorna werden.
- ⚠ Produkten får bara användas till kroppshygien med bad och dusch.
- ⚠ Stora tryckskillnader mellan anslutningarna för varmt och kallt vatten måste utjämnas.

Monteringsanvisningar

- Det måste undersökas om produkten har transportskador innan den monteras. Efter monteringen accepteras inga transport- eller ytskiktsskador.
- Ledningarna och blandaren måste monteras, spolas igenom och kontrolleras enligt de gällande normerna.
- De installationsriktlinjer som gäller i länderna ska följas.

Tekniska data

Driftstryck:	max. 1 MPa
Rek. driftstryck:	0,1 - 0,5 MPa
Tryck vid provtryckning: (1 MPa = 10 bar = 147 PSI)	1,6 MPa
Varmvattentemperatur:	max. 70°C
Rek. varmvattentemp.:	65°C
Termisk desinfektion:	max. 70°C / 4 min

Produkten är enbart avsedd för dricksvatten!

Symbolförklaring



Använd inte silikon som innehåller ättiksyra!



Justering (se sidan 33)

Ställa in varmvattenregleringen. Tillsammans med varmvattenberedare rekommenderas inte en varmvattenspär.



Hantering (se sidan 34)



Måtten (se sidan 35)



Flödesschema
(se sidan 37)

fri genomströmning

- ① Avlopp dusch
- ② Avlopp kar



Reservdelar (se sidan 38)

XXX = Färgkodning
000 = krom
090 = krom/guld-optik
400 = vit/krom
950 = brushed brass



Rengöring (se den medföljande broschyren)



Testsigill (se sidan 37)

Störning	Orsak	Åtgärd
Blandare är trög	- Patron defekt, förkalkad	- Byt ut patron
Blandare droppar	- Patron defekt	- Byt ut patron
För låg varmvattentemperatur, inget kallvatten. Varmvattenberedaren slår på när kallvatten väljs.	- Varmvattenreglering felaktigt inställd - Korsflöde	- Ställ in varmvattenreglering - Byt ut patron
Omkopplare fungerar inte	- Avlagringar - För lågt vattentryck - Omkopplare defekt	- Rengör omkastare / smörj O-ringar - Öka vattentrycket - Byt ut omkopplare



Montering se sidan 31



Saugumo technikos nurodymai

- ⚠ Apsaugai nuo užspaudimo ir įsijovimo montavimo metu mūvėkite pirštines.
- ⚠ Gaminys turi būti naudojamas tik maudymuisi, kūno higienai ir švarai palaikyti.
- ⚠ Turi būti išlyginti šalto ir karšto slėgio nelygumai.

Montavimo instrukcija

- Prieš montuojant būtina patikrinti, ar gaminys nebuvo pažeistas transportavimo metu. Sumontavus pretenzijos dėl transportavimo ir paviršiaus pažeidimų nepriimamos.
- Vamzdžiai ir sujungimai turi būti montuojami, plaunami ir tikrinami pagal galiojančias normas.
- Laikykitės atitinkamoje šalyje galiojančių direktyvų dėl įrengimo.

Techniniai duomenys

Darbinis slėgis: ne daugiau kaip 1 MPa
 Rekomenduojamas slėgis: 0,1 - 0,5 MPa
 Bandomasis slėgis: 1,6 MPa
 (1 MPa = 10 barų = 147 PSI)

Karšto vandens temperatūra: ne daugiau kaip 70°C
 Rekomenduojama karšto vandens temperatūra: 65°C
 Terminis dezinfekavimas: ne daugiau kaip 70°C / 4 min

Produktas skirtas tik geriamajam vandeniui!

Simbolio aprašymas



Nenaudokite silikono, kurio sudėtyje yra acto rūgšties!



Reguliavimas (žr. psl. 33)

Karšto vandens ribojimas. Kartu su cirkuliaciniais šildytuvais nerekomenduojama naudoti karšto vandens blokavimo įtaisų.



Eksplotacija (žr. psl. 34)



Išmatavimai (žr. psl. 35)



Pralaidumo diagrama (žr. psl. 37)

laisvas vandens pralaidumas

- ① Dušo išleidimas
- ② Vonios išleidimas



Atsarginės dalys (žr. psl. 38)

XXX = Spalvos
 000 = chrom
 090 = chrominė (aukso optika)
 400 = balta/chrom
 950 = brushed brass



Valymas (žr. pridedamoje brošiūroje)



Bandyimo pažyma (žr. psl. 37)

Gedimas	Priežastis	Priemonė
Sunkiai sukiojama rankenėlė	- Kasetė pažeista, užkalkėjusi	- Pakeisti kasetę
Maišytuvus praleidžia vandenį	- Kasetė pažeista	- Pakeisti kasetę
Per mažą karšto vandens temperatūrą, nėra šalto vandens. Momentinis pašildytojas pradeda veikti, kai naudojamas šalta vanduo	- Neteisingai nustatytas karšto vandens ribotuvus - Kryžminė srovė	- Nustatyti karšto vandens ribotuvą - Pakeisti kasetę
Perjungėjas nefunkcionuoja	- Apnašos - Nepakankamas vandens spaudimas - Pažeistas perjungėjas	- Išvalykite atsukimą/-sutepkite O-žiedus - Pakelti vandens spaudimą - Pakeisti perjungėją



Montavimas žr. psl. 31



Sigurnosne upute

- Prilikom montaže se radi sprječavanja prignječenja i posjekotina moraju nositi rukavice.
- Proizvod se smije primjenjivati samo za kupanje, tuširanje i osobnu higijenu.
- Velika razlika u pritisku između vruće i hladne vode mora biti izbalansirana.

Upute za montažu

- Prije montaže mora se provjeriti je li proizvod oštećen prilikom transporta. Nakon ugradnje se ne priznaju nikakve reklamacije koje se odnose na površinska i transportna oštećenja.
- Cijevi i armatura moraju biti postavljeni, isprani i testirani prema važećim normama.
- Obvezno se moraju uvažiti propisi o instalacijama koji vrijede u dotičnoj zemlji.

Tehnički podatci

Najveći dopušteni tlak:	tlak 1 MPa
Preporučeni tlak:	0,1 - 0,5 MPa
Probni tlak:	1,6 MPa
(1 MPa = 10 bar = 147 PSI)	
Temperatura vruće vode:	tlak 70 °C
Preporučena temperatura vruće vode:	65 °C
Termička dezinfekcija:	tlak 70 °C / 4 min

Proizvod je koncipiran isključivo za pitku vodu!

Opis simbola



Nemojte koristiti silikon koji sadrži octenu kiselinu!



Regulacija (pogledaj stranicu 33)

Namještanje limitera tople vode. U kombinaciji s protočnim bojlerima nije preporučljiva primjena sustava za blokiranje dotoka tople vode.



Upotreba (pogledaj stranicu 34)



Mjere (pogledaj stranicu 35)



Dijagram protoka (pogledaj stranicu 37)

slobodan protok

- ① Ogranak tuš
- ② Ogranak kada



Rezervni dijelovi (pogledaj stranicu 38)

XXX = Boje
000 = krom
090 = optika krom/zlato
400 = bijela/krom
950 = brushed brass



Čišćenje (se u priloženoj brošuri)



Oznaka testiranja (pogledaj stranicu 37)

Greška	Uzrok	Otklanjanje
Ručica se zaglavila	- Neispravan uložak Taloženje kamenca	- Zamijenite uložak
Slavina kaplje	- Neispravan uložak	- Zamijenite uložak
Preniska temperatura vruće vode, nedostatak hladne vode. Protočni bojler se pali pri podešenoj funkciji za protok hladne vode	- Limiter vruće vode nije dobro podešen - Križni tok vode	- Podesite limiter vruće vode - Zamijenite uložak
Selektor ne radi	- Naslage - Prenizak tlak vode - Selektor je neispravan	- Čišćenje selektora i podmazivanje O-prstenova - Povećajte tlak vode - Zamijenite selektor



Sastavljanje pogledaj stranicu 31



Güvenlik uyarıları

- Montaj esnasında ezilme ve kesilme gibi yaralanmaları önlemek için eldiven kullanılmalıdır.
- Ürün yalnızca banyo, hijyen ve beden temizliği amaçları doğrultusunda kullanılabilir.
- Sıcak ve soğuk su bağlantıları arasında büyük basınç farklılıkları varsa, bu basınç farklılıklarının dengelenmesi gerekir.

Montaj açıklamaları

- Montaj işleminden önce ürün nakliye hasarları yönünden kontrol edilmelidir. Montaj işleminden sonra nakliye veya yüzey hasarları için sorumluluk üstlenilmemektedir.
- Boruların ve armatürün montajı, yıkanması ve kontrolü geçerli normlara göre yapılmalıdır.
- Ülkelerde geçerli kurulum yönetmeliklerine riayet edilmelidir.

Teknik bilgiler

İşletme basıncı:	azami 1 MPa
Tavsiye edilen işletme basıncı:	0,1 - 0,5 MPa
Kontrol basıncı:	1,6 MPa
(1 MPa = 10 bar = 147 PSI)	
Sıcak su sıcaklığı:	azami 70°C
Tavsiye edilen su ısı:	65°C
Termik dezenfeksiyon:	azami 70°C / 4 dak

Ürün sadece şebeke suyu için tasarlanmıştır!

Simge açıklaması



Asetik asit içeren silikon kullanmayın!



Ayarlama (bakınız sayfa 33)

Sıcak su sınırlamasının ayarlanması. Sıcak su kilitinin sürekli ısıtıcıyla kullanılması tavsiye edilmez.



Kullanımı (bakınız sayfa 34)



Ölçüleri (bakınız sayfa 35)



Akış diyagramı (bakınız sayfa 37)

serbest akış

- Su püskürtücü çıkışı
- Tekne çıkışı



Yedek Parçalar (bakınız sayfa 38)

XXX = Renkler
000 = krom
090 = krom/altın-optik
400 = beyaz/Krom
950 = brushed brass



Temizleme (birlikte verilen broşür)



Kontrol işareti (bakınız sayfa 37)

arıza	sebebi	yardım
Batarya kullanımı ağırlaştırıyor	- Kartuş Bozulmuş ve kireçlenmiş olabilir	- Kartuşu değiştirin
Batarya su damlatıyor	- Kartuş bozuk olabilir	- Kartuşu değiştirin
Sıcak su sıcaklığı çok düşük, soğuk su yok. Soğuk su seçilince şofben çalışmaya başlıyor.	- Isı limitleyici düzgün çalışmıyor - Çapraz akış	- Isı limitleyiciyi yeniden ayarlayın - Kartuşu değiştirin
Divertör çalışmıyor	- Çökelmeler - Su basıncı düşük - Divertör arızalı	- Dönüştürücüyü temizleme / O ringleri yağlama - Su basıncını artırın - Divertörü değiştirin



Montajı bakınız sayfa 31



Instrucțiuni de siguranță

- ⚠ La montare utilizați mănuși pentru evitarea contuziunilor și tăierii mâinilor.
- ⚠ Produsul poate fi utilizat doar pentru spălarea, menținerea igienei și curățarea corpului.
- ⚠ Diferențele de presiune mari între alimentarea cu apă rece și apă caldă trebuie echilibrate.

Instrucțiuni de montare

- Înainte de instalare verificați, dacă produsul prezintă deteriorări de transport. După instalare garanția nu acoperă deteriorările de transport și cele de suprafață.
- Conductele și bateriile trebuie montate, spălate și verificate conform normelor în vigoare.
- Respectați reglementările referitoare la instalare valabile în țara respectivă.

Date tehnice

Presiune de funcționare:	max. 1 MPa
Presiune de funcționare recomandată:	0,1 - 0,5 MPa
Presiune de verificare:	1,6 MPa
(1 MPa = 10 bar = 147 PSI)	
Temperatura apei calde:	max. 70°C
Temperatura recomandată a apei calde:	65°C
Dezinfecție termică:	max. 70°C / 4 min

Produsul este destinat exclusiv pentru apă potabilă.

Descrierea simbolurilor



Nu utilizați silicon cu conținut de acid acetic!



Reglare (vezi pag. 33)

Reglarea limitatorului de apă caldă. Nu se recomandă folosirea unui limitator de apă caldă în combinație cu un boiler instant.



Utilizare (vezi pag. 34)



Dimensiuni (vezi pag. 35)



Diagrama de debit

(vezi pag. 37)

debit cu curgere liberă

- ① Orificiu de scurgere duș
- ② Orificiu de scurgere vană



Piese de schimb (vezi pag. 38)

XXX = Coduri de culori
000 = crom
090 = crom/auriu optic
400 = alb/crom
950 = brushed brass



Curățare (vezi broșura alăturată)



Certificat de testare

(vezi pag. 37)

Deranjament	Cauza	Măsuri de remediere
Bateria se mișcă dificil	- Cartuș defect din cauza depunerilor de calcar	- Schimbați cartușul.
Bateria picură	- Cartuș defect	- Schimbați cartușul.
Temperatura apei este prea mică, nu este apă rece. Boilerul instant pornește când se dă drumul la apa rece	- Limitarea temperaturii apei calde setată incorect. - Curgere încrucișată (apa rece în intră în conducta de apă caldă și invers)	- Setați limitarea temperaturii apei calde. - Schimbați cartușul.
Cartușul nu funcționează.	- Depuneri - Presiune apă prea mică - Cartuș defect	- Curățați inversorul / ungeți inelele O - Măriți presiunea de apă - Schimbați cartușul.



Montare vezi pag. 31



⚠ Υποδείξεις ασφαλείας

- ⚠ Για να αποφύγετε τραυματισμούς κατά τη συναρμολόγηση πρέπει να φοράτε γάντια.
- ⚠ Το προϊόν επιτρέπεται να χρησιμοποιείται μόνο σαν μέσο λουτρού, υγιεινής και καθαρισμού του σώματος.
- ⚠ Οι διαφορές της πίεσης μεταξύ της σύνδεσης κρύου και ζεστού νερού θα πρέπει να αντισταθμίζονται.

Οδηγίες συναρμολόγησης

- Πριν τη συναρμολόγηση πρέπει να εξεταστεί το προϊόν για ζημιές μεταφοράς. Μετά την εγκατάσταση δεν αναγνωρίζονται ζημιές από τη μεταφορά ή επιφανειακές ζημιές.
- Οι σωλήνες και η μπαταρία πρέπει να τοποθετηθούν σύμφωνα με τα ισχύοντα πρότυπα, να τεθούν υπό πίεση και να δοκιμαστούν.
- Θα πρέπει να τηρούνται οι οδηγίες εγκατάστασης που ισχύουν σε κάθε κράτος.

Τεχνικά Χαρακτηριστικά

Λειτουργία πίεσης:	έως 1 MPa
Συνιστώμενη λειτουργία πίεσης:	0,1 - 0,5 MPa
Πίεση ελέγχου:	1,6 MPa
(1 MPa = 10 bar = 147 PSI)	
Θερμοκρασία ζεστού νερού:	έως 70°C
Συνιστώμενη θερμοκρασία ζεστού νερού:	65°C
Θερμική απολύμανση:	έως 70°C / 4 min

Το προϊόν έχει σχεδιαστεί αποκλειστικά για πόσιμο νερό!

Περιγραφή συμβόλων



Μην χρησιμοποιείτε σιλικόνη που περιέχει οξικό οξύ!



Ρύθμιση (βλ. Σελίδα 33)

Ρύθμιση του δοσομετρητή ζεστού νερού. Δεν συνιστάται η διάταξη φραγής ζεστού νερού σε συνδυασμό με ταχυθερμοσίφωνα.



Χειρισμός (βλ. Σελίδα 34)



Διαστάσεις (βλ. Σελίδα 35)



Διάγραμμα ροής (βλ. Σελίδα 37)

Ελεύθερη ροή

- ① Εξοδος ντους
- ② Εξοδος μπανιέρας



Ανταλλακτικά (βλ. Σελίδα 38)

XXX = Χρώματα
000 = Επιχρωμιωμένο
090 = Επιχρωμιωμένο/οπτική χρυσού
400 = λευκό/Επιχρωμιωμένο
950 = brushed brass



Καθαρισμός (βλ. συνημμένο φυλλάδιο)



Σήμα ελέγχου (βλ. Σελίδα 37)

Βλάβη	Αιτία	Διόρθωση
Σκληρή μπαταρία (μεικτής)	- Ελαττωματικό φυσιγγίο, άλατα	- Αλλαγή φυσιγγίου
Η μπαταρία στάζει	- Ελαττωματικό φυσιγγίο	- Αλλαγή φυσιγγίου
Χαμηλή θερμοκρασία ζεστού νερού, καθόλου κρύο νερό. Ο ταχυθερμοσίφωνα ενεργοποιείται, όταν επιλέγεται το κρύο νερό.	- Λάθος ρύθμιση της περιοριστικής διάταξης ζεστού νερού - Σταυροειδής ροή	- Ρυθμίστε την περιοριστική διάταξη του ζεστού νερού - Αλλαγή φυσιγγίου
Ο διακόπτης επιλογής δεν λειτουργεί	- Άλατα	- Καθαρίστε τον ρυθμιστή νερού / λιπάνετε τους στεγανωτικούς δακτυλίους
	- Ανεπαρκής πίεση νερού	- Αυξήστε την πίεση του νερού
	- Βλάβη στο διακόπτη επιλογής	- Αλλάξτε το διακόπτη επιλογής



Συναρμολόγηση βλ. Σελίδα 31



Varnostna opozorila

- ⚠ Pri montaži je treba nositi rokavice, da se preprečijo poškodbe zaradi zmečkanja ali urezov.
- ⚠ Ta izdelek se sme uporabljati le z namenom umivanja, vzdrževanja higijene in telesne nege.
- ⚠ Velike razlike v tlaku med priključkom za mrzlo in priključkom za toplo vodo je potrebno izravnati.

Navodila za montažo

- Pred montažo je treba izdelek preveriti glede morebitnih transportnih poškodb. Po vgradnji transportne ali površinske poškodbe ne bodo več priznane.
- Cevi in armaturo je treba montirati, izprati in preveriti po veljavnih standardih.
- Upoštevati je treba pravilnike o inštalacijah, ki veljajo v posamezni državi.

Tehnični podatki

Delovni tlak:	maks. 1 MPa
Priporočeni delovni tlak:	0,1 - 0,5 MPa
Preskusni tlak:	1,6 MPa
(1 MPa = 10 bar = 147 PSI)	
Temperatura tople vode:	maks. 70 °C
Priporočena temperatura tople vode:	65 °C
Termična dezinfekcija:	maks. 70 °C / 4 min

Proizvod je zasnovan izključno za sanitarno vodo!

Opis simbola



Ne smete uporabiti silikona, ki vsebuje ocetno kislino!



Justiranje (glejte stran 33)

Nastavitev omejevalnika tople vode. V povezavi s pretočnimi grelniki uporaba zapore tople vode ni priporočljiva.



Upravljanje (glejte stran 34)



Mere (glejte stran 35)



Diagram pretoka

(glejte stran 37)

prost pretok

- ① Odvod prhe
- ② Odvod banje



Rezervni deli (glejte stran 38)

XXX = Barve
000 = krom
090 = krom/pozlačena
400 = bela/krom
950 = brushed brass



Čiščenje (glejte priloženi brošuri)



Preskusni znak (glejte stran 37)

Napaka	Vzrok	Pomoč
Težko premikanje armature	- Pokvarjen vložek, poapneno	- Zamenjajte vložek
Iz armature kaplja	- Pokvarjen vložek	- Zamenjajte vložek
Prenizka temperatura tople vode, ni mrzle vode. Pretočni grelnik se sproži, kadar izberete mrzlo vodo.	- Omejevalnik tople vode ni pravilno nastavljen	- Nastavite omejevalnik tople vode
Preklopnik ne deluje	- Križni tok	- Zamenjajte vložek
	- Obloge	- Očistite premičnik / namastite obročno tesnilo
	- Prenizek vodni tlak	- Povečajte vodni tlak
	- Preklopnik je pokvarjen	- Zamenjajte preklopnik



Montaža glejte stran 31



Ohutusjuhised

- △ Kandke paigaldamisel muljumis- ja löikevigastuste vältimiseks kindaid.
- △ Toodet tohib kasutada ainult pesemis-, hügieeni- ja kehapihustamiseesmärkidel.
- △ Kui külma ja kuuma vee ühenduste surve on väga erinev, tuleb need tasakaalustada.

Paigaldamisjuhised

- Enne paigaldamist tuleb toodet kontrollida transpordikahjustuste osas. Pärast paigaldamist ei tunnustata enam transpordi- või pinnakahjustuste kaebuseid.
- Voolikute ja segisti paigaldamisel, loputamisel ja kontrollimisel tuleb lähtuda kehtivatest normatiividest.
- Vastavas riigis kehtivaid paigalduseeskirju tuleb järgida.

Tehnilised andmed

Töörõhk	maks. 1 MPa
Soovitatav töörõhk:	0,1 - 0,5 MPa
Kontrollsurve:	1,6 MPa
(1 MPa = 10 baari = 147 PSI)	
Kuuma vee temperatuur:	maks. 70 °C
Soovitatav kuuma vee temperatuur:	65 °C
Termiline desinfitatsioon:	maks. 70 °C / 4 min

Toode on ette nähtud eranditult joogivee jaoks!

Sümbolite kirjeldus



Ärge kasutage äädikhapet sisaldavat silikooni!



Reguleerimine (vt lk 33)

Sooja vee piirangu seadistamine. Ühenduses boileritega ei ole sooja vee blokeeringu soovitatav.



Kasutamine (vt lk 34)



Mõõtude (vt lk 35)



Läbivooludiagramm

(vt lk 37)

äravoolu surve

- ① Duši väljund
- ② Vanni väljund



Varuosad (vt lk 38)

XXX = Värvid
000 = kroom
090 = kroom/kuld optik
400 = valge/kroom
950 = brushed brass



Puhastamine (vt kaasasolevast brošüürist)



Kontrollsertifikaat (vt lk 37)

Rike	Põhjus	Lahendus
Segisti käib raskelt	- Tööelement on katkine, lubjastunud	- Vahetage tööelement
Segisti tilgub	- Tööelement on katkine	- Vahetage tööelement
Liiga madal sooja vee temperatuur, külma vett pole. Läbivoolu boiler hakkab tööle, kui on valitud külm vesi.	- Kuuma vee piirang valesti seatud - Ristvool	- Seadke kuuma vee piirang - Vahetage tööelement
Ümberlülit ei tööta	- Setted	- Ümberlülit puhastamine / O-tihendite määrimine
	- Vee surve liiga madal	- Tõstke vee survet
	- Ümberlülit defektne	- Ümberlülit välja vahetada



Paigaldamine vt lk 31



Drošības norādes

- ⚠ Montāžas laikā, lai izvairītos no saspiedumiem un iegriezumiem, nepieciešams nēsāt cimdus.
- ⚠ Šo produktu drīkst izmantot tikai, lai mazgātos, higiēnai un ķermeņa tīrīšanai.
- ⚠ Jāizlīdzina spiediena atšķirības starp aukstā un karstā ūdens pievadiem.

Norādījumi montāžai

- Pirms montāžas nepieciešams pārbaudīt, vai produktam transportēšanas laikā nav radušies bojājumi. Pēc iebūvēšanas bojājumi, kas radušies transportēšanas laikā, vai virsmas bojājumi netiek atzīti.
- Caurulvadi un armatūra ir jāuzstāda, jāizskalo un jāpārbauda saskaņā ar spēkā esošajiem standartiem.
- Jāievēro attiecīgās valstīs spēkā esošās montāžas prasības.

Tehniskie dati

Darba spiediens: maks. 1 MPa
 Ieteicamais darba spiediens: 0,1 - 0,5 MPa
 Pārbaudes spiediens: 1,6 MPa
 (1 MPa = 10 bar = 147 PSI)
 Karstā ūdens temperatūra: maks. 70 °C
 Ieteicamā karstā ūdens temperatūra: 65 °C
 Termiskā dezinfekcija : maks. 70 °C / 4 min

Izstrādājums ir paredzēts tikai dzeramajam ūdenim!

Simbolu nozīme



Neizmantojot silikonu, kas satur etiķskābi!



Ieregulēšana (skat. lpp. 33)

Karsta ūdens ierobežotāja regulēšana.
 Kopā ar caurteces sildītājiem nav ieteicams izmantot ūdens bloķētāju.



Lietošana (skat. lpp. 34)



Izmērus (skat. lpp. 35)



Caurplūdes diagramma

(skat. lpp. 37)

brīva caurplūde

- ① Dušas izeja
- ② Vannas izeja



Rezerves daļas (skat. lpp. 38)

XXX = Krāsu kodi
 000 = hroma
 090 = hroma/zelta
 400 = balta/hroma
 950 = brushed brass



Tīrīšana (skatiet pievienotajā brošūrā)



Pārbaudes zīme (skat. lpp. 37)

Traucējums	Iemesls	Bojājumu novēršana
Jaucējkrāns smagi grozāms	- Bojāta kartuša, aizkalkojusies	- Nomainīt kartušu
Jaucējkrāns pil	- Bojāta kartuša	- Nomainīt kartušu
Pārāk zema ūdens temperatūra, nav aukstā ūdens, izvēloties auksto ūdeni, sāk darboties caurteces sildītājs	- Nepareizi noregulāta karstā ūdens bloķēšana - Ūdens sajaukšanās	- Noregulēt karstā ūdens ierobežošanu - Nomainīt kartušu
Pārslēdzējs nestrādā	- Nogulsnes - Nepietiekams ūdens spiediens - Bojāts pārslēdzējs	- Tīriet pārslēdzēju / eļļojiet blīvējošos gredzenus - Pacaugstināt ūdens spiedienu - Nomainīt pārslēdzēju



Montāža skat. lpp. 31



Sigurnosne napomene

- ⚠ Prilikom montaže se radi sprečavanja prignječenja i posekotine moraju nositi rukavice.
- ⚠ Proizvod sme da se koristi samo za kupanje, tuširanje i ličnu higijenu.
- ⚠ Velika razlika u pritisku između vruće i hladne vode mora biti izbalansirana.

Instrukcije za montažu

- Pre montaže se mora proveriti da li je proizvod oštećen pri transportu. Nakon ugradnje se ne priznaju nikakve reklamacije koje se odnose na površinska i transportna oštećenja.
- Vodovi i armatura moraju biti postavljeni, isprani i testirani prema važećim normama.
- Treba se pridržavati propisa koji u određenim zemljama važe za instalacije.

Tehnički podaci

Radni pritisak:	maks. 1 MPa
Preporučeni radni pritisak:	0,1 - 0,5 MPa
Probni pritisak:	1,6 MPa
(1 MPa = 10 bar = 147 PSI)	
Temperatura vruće vode:	maks. 70 °C
Preporučena temperatura vruće vode:	65 °C
Termička dezinfekcija:	maks. 70 °C / 4 min

Proizvod je koncipiran isključivo za pijaću vodu!

Opis simbola



Nemojte koristiti silikon koji sadži sirćetnu kiselinu!



Podešavanje (vidi stranu 33)

Podešavanje ograničivača tople vode. U kombinaciji sa protočnim bojlerima ne preporučuje se primena sistema za blokiranje dotoka tople vode.



Rukovanje (vidi stranu 34)



Mere (vidi stranu 35)



Dijagram protoka (vidi stranu 37)

slobodan protok

- ① Ogranak tuš
- ② Ogranak kada



Rezervni delovi (vidi stranu 38)

XXX = Oznake boja
000 = hrom
090 = dezen hrom/zlatna
400 = bela/hrom
950 = brushed brass



Čišćenje (vidi priloženoj brošuri)



Ispitni znak (vidi stranu 37)

Smetnja	Uzrok	Pomoć
Ručica se zaglavila	- Neispravna kartuša, nataloženi kamenac	- Zamenite kartušu
Slavina kaplje	- Neispravna kartuša	- Zamenite kartušu
Preniska temperatura tople vode, nema hladne vode. Protočni bojler se pali iako je puštena hladna voda.	- Ograničavač vruće vode nije dobro podešen - Ukršteni tok vode	- Podesite ograničavač vruće vode - Zamenite kartušu
Preusmerivač ne radi	- Naslage - Prenizak pritisak vode - Preusmerivač je neispravan	- Čišćenje preusmerivača i podmazivanje O-prstenova - Povećajte pritisak vode - Zamenite preusmerivač



Montaža vidi stranu 31



Sikkerhetshenvisninger

- ⚠ Bruk hansker under montasjen for å unngå klem- og kuttskader.
- ⚠ Produktet skal kun brukes for bade-, hygiene- og kroppshygiene.
- ⚠ Store trykkdifferanser mellom kaldt- og varmtvannstilkoblinger skal utlignes.

Montagehenvisninger

- Før montasjen skal produktet sjekkes for transportskader. Etter monteringen aksepteres ikke noen transport- eller overflateskader.
- Ledningene og armaturen skal monteres, spyles og sjekkes iht. de gyldige normer.
- Gjeldende retningslinjer for rørleggerarbeid i de enkelte land skal følges.

Tekniske data

Driftstrykk maks. 1 MPa
 Anbefalt driftstrykk: 0,1 - 0,5 MPa
 Prøvetrykk 1,6 MPa
 (1 MPa = 10 bar = 147 PSI)
 Varmtvannstemperatur maks. 70°C
 Anbefalt temperatur for varmt vann 65°C
 Termisk desinfisering: maks. 70°C / 4 min

Produktet er utelukkende designet for drikkevann!

Symbolbeskrivelse



Ikke bruk silikon som inneholder eddiksyre!



Justering (se side 33)

Innstilling av varmtvannsbegrensning. I forbindelse med gjennomstrømningsvarmere er det ikke anbefalt å bruke en varmtvannssperre.



Betjening (se side 34)



Mål (se side 35)



Gjennomstrømningsdiagram

(se side 37)

fri gjennomstrømning

- ① Utgang dusj
- ② Utgang kar



Serviceleder (se side 38)

XXX = Fargekode
 000 = krom
 090 = krom/gull-optikk
 400 = hvit/krom
 950 = brushed brass



Rengjøring (se vedlagt brosjyre)



Prøvemerket (se side 37)

Feil	Årsak	Feilrettelse
Armaturløst	- Kartusj defekt, forkalkning	- Kartusj byttes
Armaturløst	- Kartusj defekt	- Kartusj byttes
For lav varmtvannstemperatur, ikke noe kaldtvann, gjennomstrømningsvarmer slår seg på når det velges kaldt vann.	- Varmtvannsbegrensning er feil innstilt	- Varmtvannsbegrensning innstilles
	- Krysstrømning	- Kartusj byttes
Omstiller fungerer ikke	- Avleiringer	- Rengjøre omstiller / smøre O-ringer
	- For lavt vanntrykk	- Øke vanntrykk
	- Omstiller defekt	- Omstiller byttes



Montasje se side 31



Указания за безопасност

- При монтажа трябва да се носят ръкавици, за да се избегнат наранявания поради притискане или порязване.
- Позволено е използването на продукта само за къпане, хигиена и цели на почистване на тялото.
- Големите разлики в налягането между изводите за студената и топлата вода трябва да се изравняват.

Указания за монтаж

- Преди монтажа продуктът трябва да се провери за транспортни щети. След монтажа не се признават транспортни или повърхностни щети.
- Тръбопроводите и арматурата трябва да се монтират, промият и проверят в съответствие с валидните норми.
- Трябва да бъдат спазвани валидните в съответните страни предписания за инсталиране.

Технически данни

Работно налягане:	макс. 1 МПа
Препоръчително работно налягане:	0,1 - 0,5 МПа
Контролно налягане:	1,6 МПа
(1 МПа = 10 bar = 147 PSI)	
Температура на горещата вода:	макс. 70 °C
Препоръчителна температура на горещата вода:	65 °C
Термична дезинфекция:	макс. 70 °C / 4 мин

Продуктът е разработен само за питейна вода!

Описание на символите



Не използвайте силикон, съдържащ оцетна киселина!



Юстиране (вижте стр. 33)

Настройка на ограничителя за топлата вода. Във връзка с проточни нагреватели не се препоръчва блокировка за топлата вода



Обслужване (вижте стр. 34)



Размери (вижте стр. 35)



Диаграма на потока (вижте стр. 37)

свободен поток

- ① Изход разпръсквател
- ② Извод вана



Сервизни части (вижте стр. 38)

XXX = Цветово кодиране
000 = хром
090 = хром/оптика за злато
400 = бял/хром
950 = brushed brass



Почистване (от приложената брошура)



Контролен знак (вижте стр. 37)

Неизправност

Причина

Помощ

Трудно подвижна арматура	- Дефектна гилза, покрита с варовик	- Сменете гилзата
Арматурата капе	- Дефектна гилза	- Сменете гилзата
Твърде ниска температура на топлата вода, няма студена вода. Проточният нагревател се задейства, когато се избере студена вода	- Ограничението за топлата вода е грушно настроено - Кръстосване на потока	- Настройте ограничението за топлата вода - Сменете гилзата
Превключвателят не функционира	- Отлагания - Твърде малко налягане на водата - Дефектен превключвател	- Почистете превключвателя / Смажете O-образните пръстени - Повишаване на налягането на водата - Сменете превключвателя



Монтаж вижте стр. 31



Udhëzime sigurie

- ⚠ Për të evituar lëndimet e pickimeve ose të prerjeve gjatë procesit të montimit duhet që të vishni doreza.
- ⚠ Produkti duhet të përdoret vetëm qëllimet e banjave, të higjienës dhe të larjes së trupit.
- ⚠ Ndryshimet e mëdha të presionit mes lidhjeve të ujit të ftohtë dhe atij të ngrohtë duhen ekuilibruar.

Udhëzime për montimin

- Përpara montimit duhet që produkti të kontrollohet për dëmtime nga transporti. Pas instalimit nuk do të njihet asnjë dëmtim nga transporti ose dëmtim i sipërfaqes.
- Tubacionet dhe rubinetet duhet që të montohen, të shpëlahen dhe të kontrollohen sipas standardeve në fuqi
- Duhet të respektohen linjat udhëzuese të instalimit, të vlefshme për vendet respektive.

Të dhëna teknike

Presioni gjatë punës	maks. 1 MPa
Presioni i rekomanduar:	0,1 - 0,5 MPa
Presioni për provë:	1,6 MPa
(1 MPa = 10 bar = 147 PSI)	
Temperatura e ujit të ngrohtë	maks. 70 °C
Temperatura e rekomanduar e ujit të ngrohtë:	65 °C
Dezinfektim Termik:	maks. 70 °C / 4 min

Produkti është projektuar ekskluzivisht për ujë të pijshëm!

Përshkrimi i simbolit



Mos përdorni silikon që në përbërje ka acid acetik.



Justimi (shih faqen 33)

Rregullimi i kufizimit me ujë të nxehtë. Një kombinim me një bojler ujit nuk është i rekomanduar.



Përdorimi (shih faqen 34)



Përmasat (shih faqen 35)



Diagrami i qarkullimit
(shih faqen 37)

rrjedhja e lirë

- ① Dalja e spërkatëses
- ② Dalja e vaskës



Pjesët e servisit (shih faqen 38)

XXX = Kodimi me anë të ngjyrave
 000 = krom
 090 = krom/i arte-optike
 400 = e bardhë/krom
 950 = brushed brass



Pastrimi (shikoni broshurën bashkëngjitur)



Shenja e kontrollit (shih faqen 37)

Demtim	Shkaku	Ndihme
Armatura punon rende	- Kartusha me defekt, me kalk	- Kembeni kartushen
Armatura pikon	- Kartusha me defekt	- Kembeni kartushen
Temperaturë e ulët e ujit të ngrohtë, nuk ka ujë të ftohtë. Ngrohësi elektrik i ujit ndizet kur zgjidhet uji i ftohtë.	- Kufiri i ujit të ngrohtë është regjistruar gabim	- Regjistroni kufirin e ujit të ngrohtë
Kalibruesi nuk funksionon	- Rrjedhje e kryqëzuar.	- Kembeni kartushen
	- Dekompozimet	- Pastroni ndërruesin e pozicionit / Vajosni unazat O
	- Presion shumë i ulët i ujit	- Rrisni presionin e ujit
	- Kalibruesi me defekt	- kembeni kalibruesin



Montimi shih faqen 31



هام! لا تستخدم السليكون الذي يحتوي على أمضاض!



(راجع صفحة 33)

ضبط تحديد المياه الدافئة. لا ينصح باستخدام محدد المياه الدافئة مع سخان المياه الوقفي.



(راجع صفحة 34)



(راجع صفحة 35)

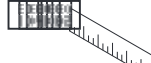

(راجع صفحة 37)

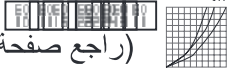

التدفق الحر

- ① صرف الرشاش
- ② صرف البانيو

(راجع صفحة 38)



- XXX = الألوان
- 000 = كروم
- 090 = كروم/لون ذهبي
- 400 = أبيض/كروم
- brushed brass = 950

(راجع والكتيب المرفق)



(راجع صفحة 37)



⚠ يجب إرتداء قفازات لليد أثناء التركيب لتجنب حدوث أخطار الإنحشار أو الجروح.

⚠ لا يجب استخدام المنتج إلا في أغراض الاستحمام والأغراض الصحية وأغراض تنظيف الجسم.

⚠ يجب أن يكون تيار الماء الساخن والماء البارد متعادلين في الضغط.



• قبل القيام بعملية التركيب، يجب فحص المنتج للتأكد من خلوه من أية تلفيات ناتجة عن النقل. بعد القيام بعملية التركيب، لن يتم الاعتراف بوجود أية تلفيات سطحية أو تلفيات ناتجة عن عملية النقل.

• يجب تركيب وغسيل واختبار التوصيلات وخلطات المياه طبقاً للمعايير السارية.

• يجب مراعاة القواعد الخاصة بالتركيب وأعمال السباكة وفقاً للوائح الخاصة بكل بلد.



ضغط التشغيل: الحد الأقصى 1 ميجاباسكال

ضغط التشغيل الموصى به: 0,5 - 0,1 ميجاباسكال

ضغط الاختبار: 1,6 ميجاباسكال

(1 ميجاباسكال = 10 بار = 147 PSI)

درجة حرارة الماء الساخن: الحد الأقصى 70°C

درجة الحرارة الموصى بها للماء الساخن: 65°C

تقييم حراري: الحد الأقصى 70°C / 4 الدقيقة

المنتج مخصص فقط لماء الشرب!



الخلاط ثقيل الحركة - الخرطوشة تالفة، تراكم عليها الجير - قم بتغيير الخرطوشة

تساقط قطرات مياه من الخلاط - الخرطوشة تالفة - قم بتغيير الخرطوشة

درجة حرارة الماء الساخن منخفضة - محدد الماء الساخن مضبوط بشكل خاطيء - قم بضبط محدد الماء الساخن

المياه الفوري يعمل عند استخدام الماء - اندفاع متعاكس للمياه - قم بتغيير الخرطوشة

المحول لا يعمل - الرواسب - تنظيف الخلاط وتشحيم الحلقة الدائرية.

البراد.

البراد.

البراد.

البراد.

البراد.

البراد.



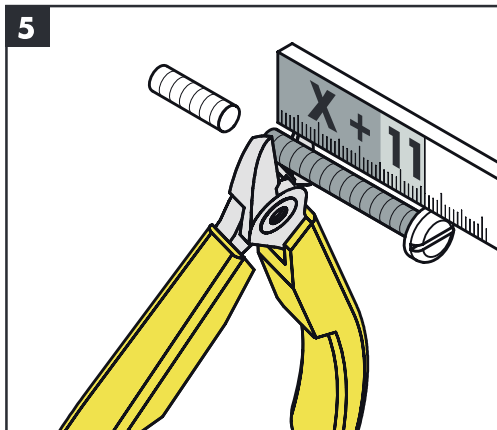
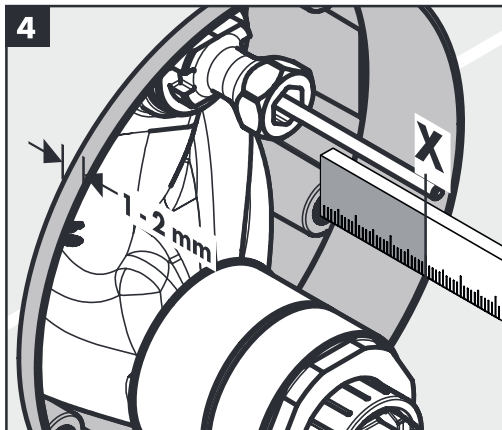
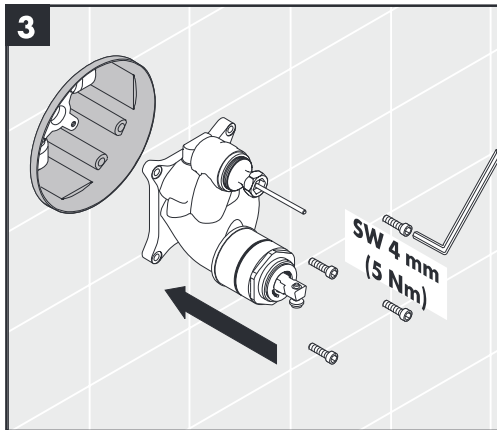
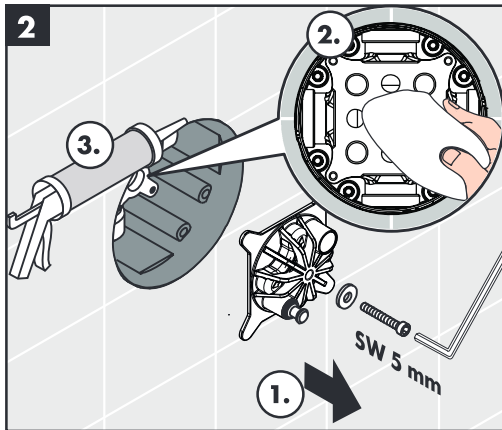
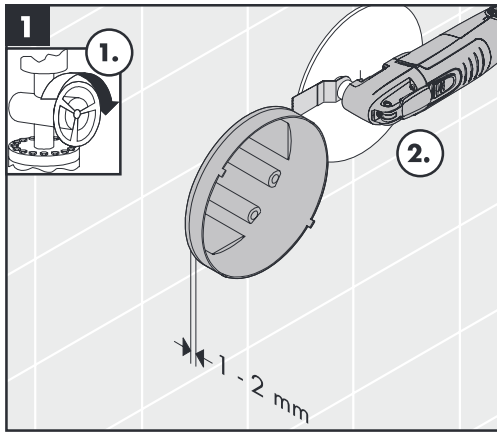
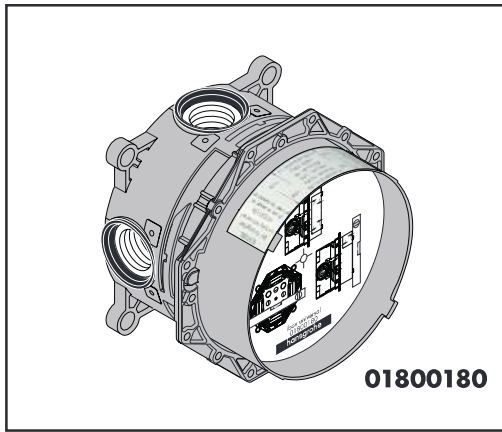

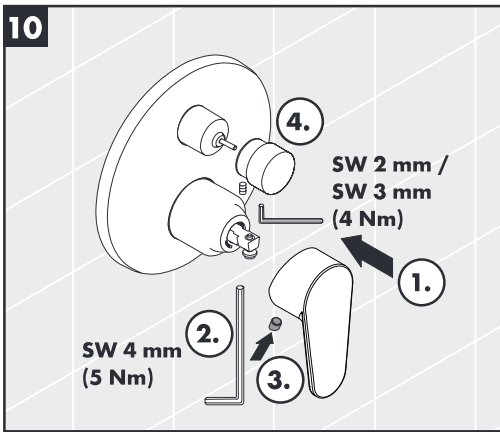
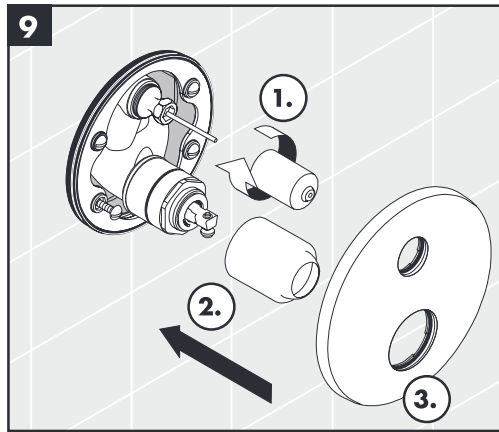
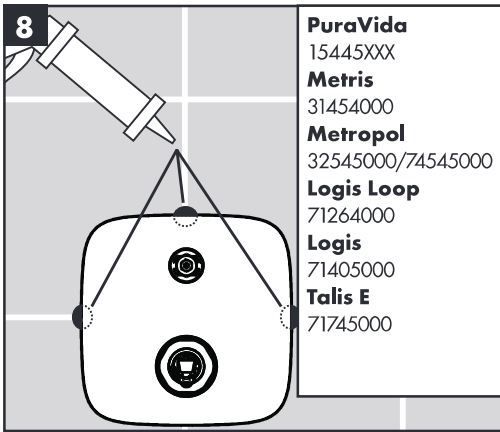
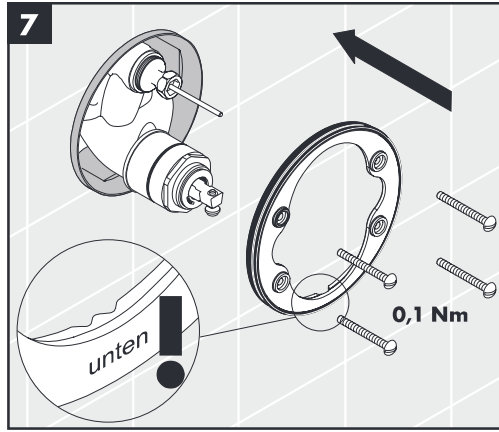
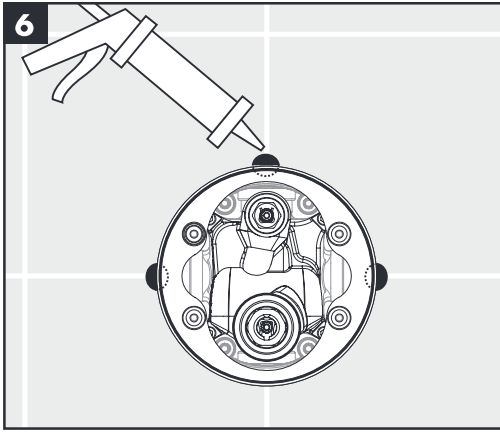

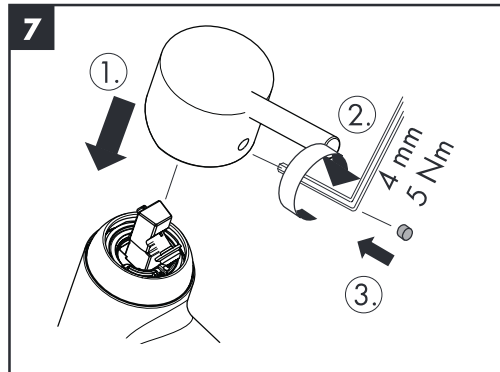
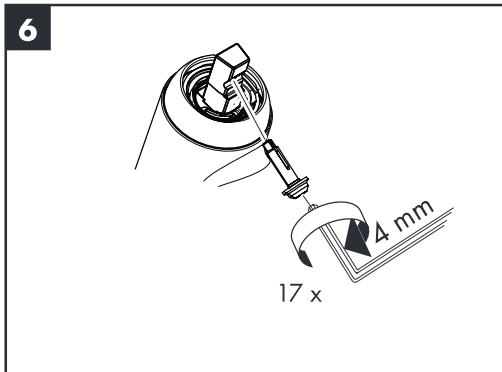
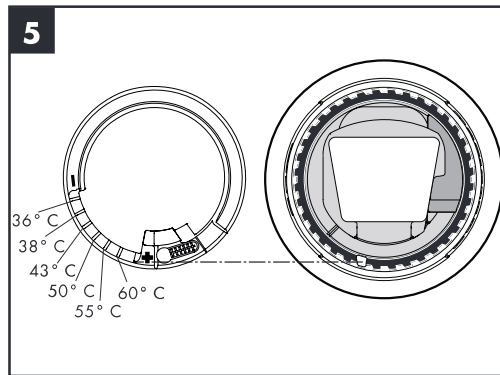
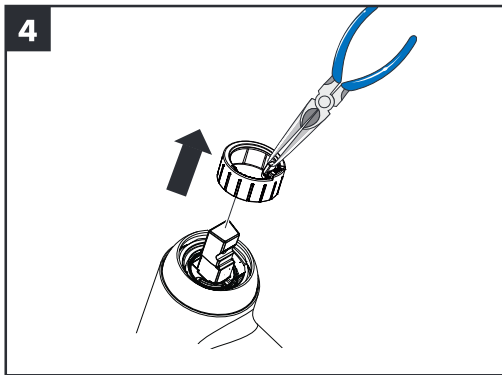
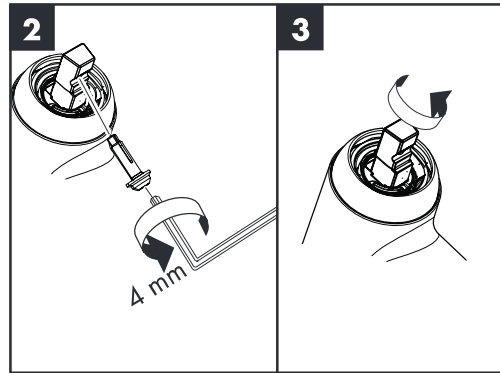
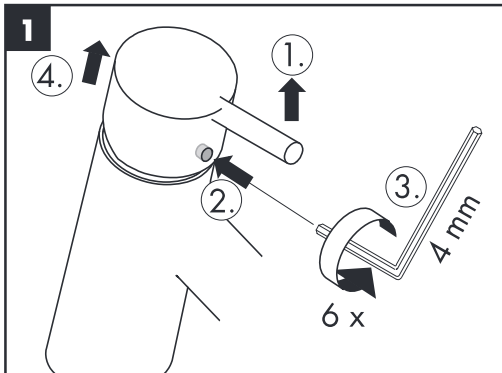

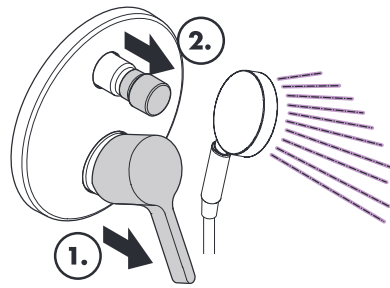
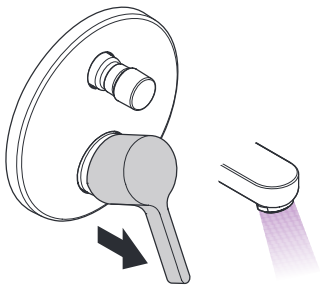

öffnen / ouvert / open / aperto / abierto / open / åbne / abrir / otworzyć / otevřít / otvorit / 开 / открыть / nyitás /
 avaaaminen / öppna / atidaryti / Otvaranje / açmak / deschide / ανοικτό / odpreti / avage / atvērt / otvoriti /
 åpne / отварање / hare / فتح

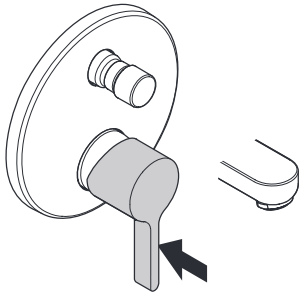

schließen / fermé / close / chiudere / cerrar / sluiten / lukke / fechar / zamknąć / zavřít / uzavrieť / 关 / закрыть /
 bezárás / sulkeminen / stänga / uždaryti / Zatvaranje / kapatmak / închide / κλειστό / zapreti / sulgege / aizvērt /
 zatvori / lukke / затварање / mbylle / إغلاق

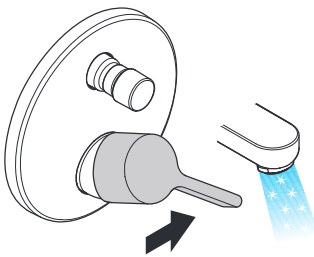
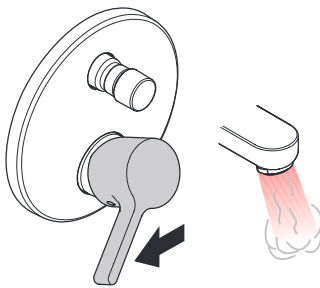

warm / chaud / hot / caldo / caliente / warm / varmt /
 quente / ciepła / teplá / teplá / 热 / горячая / meleg /
 lämmin / varmi / karštas / Vruća voda / sıcak / cald /
 ζεστό / toplo / kuum / karsts / topla / varm / тепло /
 i ngrohtë / ساخن

kalt / froid / cold / freddo / frío / koud / koldt / fria /
 zimna / studená / studená / 冷 / холодная / hideg /
 kylmä / kallt / šaltas / Hladno / soğuk / rece / krūo /
 mrzlo / külm / auksts / hladno / kaldt / студено / i ftohtë /
 ❄️



Talis Classic
14145000

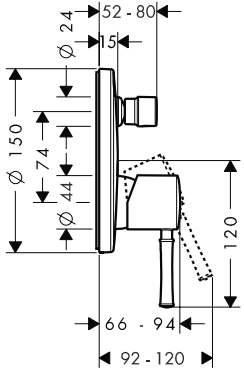

PuraVida
15445XXX

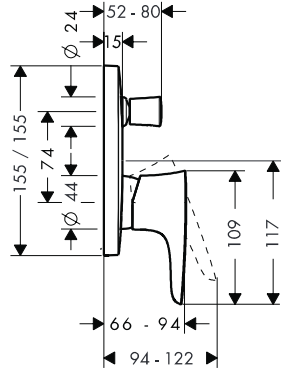

Metropol Classic
31345XXX

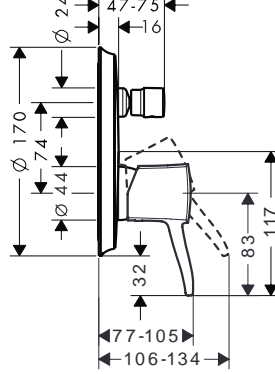

Metris
31454000

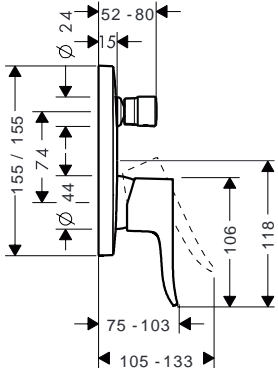

Metris S
31465000

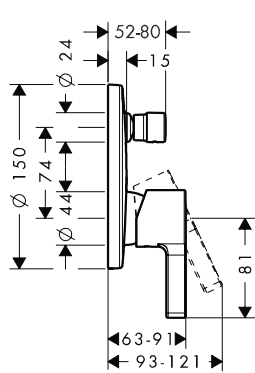

Metris Classic
31485000

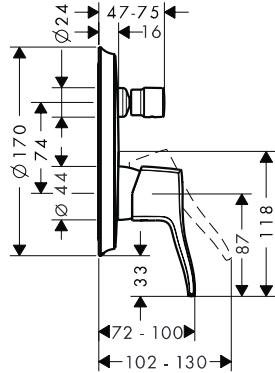

Metris
31493000

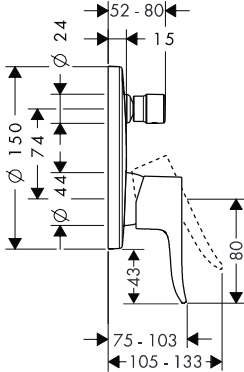

Talis E²
31645000

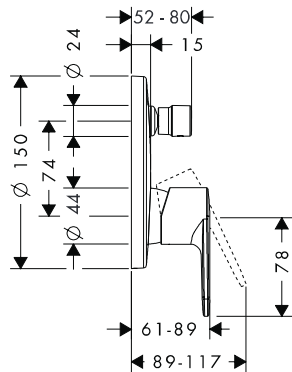

Focus
31945000

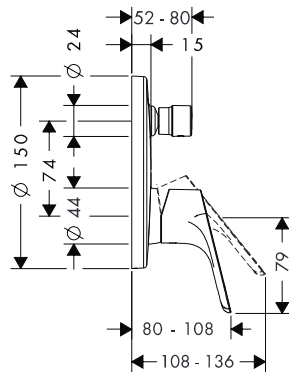



Talis S
32475XXX / 32475003

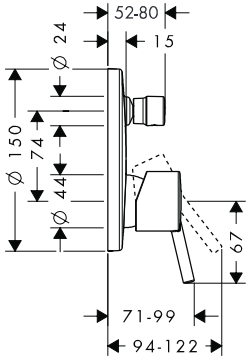

Metropol
32545000 / 74545000

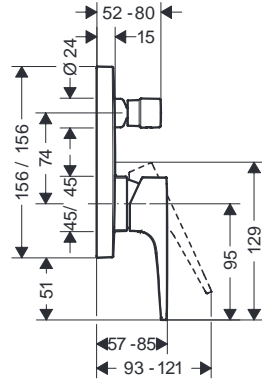

Novus
71045000

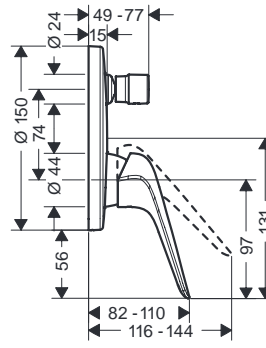

Logis Loop
71264000

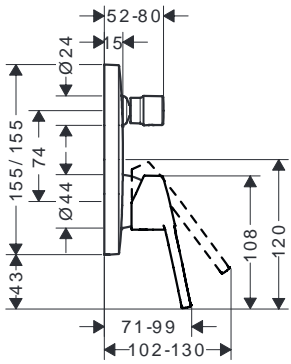

Novus Loop
71345000

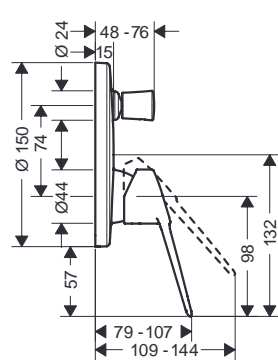

Logis E
71404000

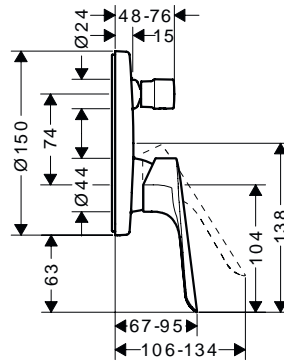

Logis
71405000

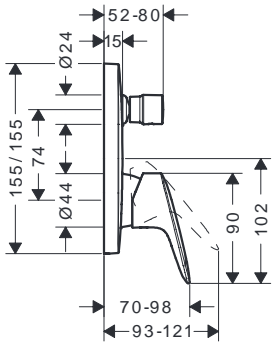

Talis E
71745000

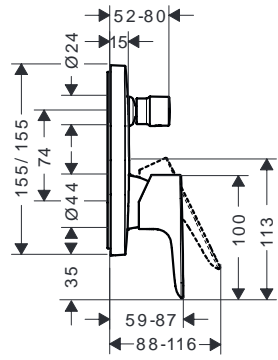

Talis S
72406000

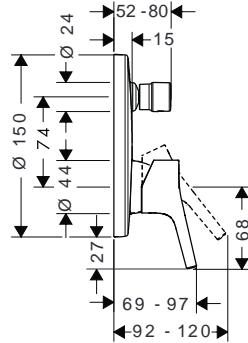

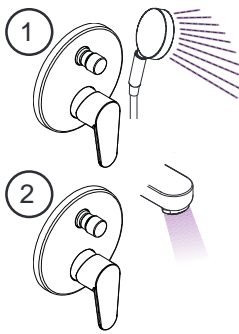
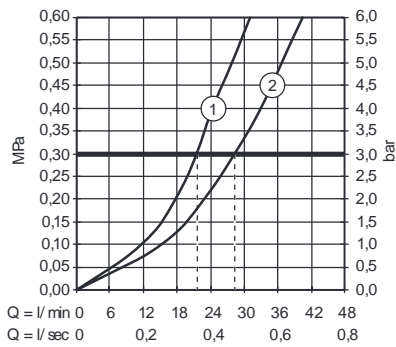

	PI-X	DVGW	SVGW	WRAS	KIWA	NF	ACS	ETA	
14145000	PA-IX9709/ICC	CQ0125	X	X			X	VA1.42/18751	1392
15445XXX	PA-IX9709/ICC	CQ0125	X	X			X	VA1.42/18751	1392
31345XXX							X		1392
31454000							X		
31465000	PA-IX9709/ICC	CQ0125	X	X	X			VA1.42/18751	1392
31485000	PA-IX9709/ICC	CQ0125	X	X			X	VA1.42/18751	1392
31493000	PA-IX9709/ICC	CQ0125	X	X			X	VA1.42/18751	1392
31645000	PA-IX9709/ICC	CQ0125	X	X	X		X	VA1.42/18751	
31945000	PA-IX9709/ICC	CQ0125	X	X		X	X	VA1.42/18751	1392
32475XXX	PA-IX9709/ICC	CQ0125	X	X	X		X	VA1.42/18751	1392
32475003									
32545000							X		1392
71045000									
71264000							X		1392
71345000									
71404000									
71405000	PA-IX9709/ICC	CQ0125	X	X		X	X	VA1.42/18751	1392
71745000	PA-IX9709/ICC						X	VA1.42/18751	1392
72405000	PA-IX9709/ICC						X	VA1.42/18751	1392
74545000							X		1392





Talis Classic 14145000 / **Metris S** 31465000 / **Metris** 31493000 / **Talis E²** 31645000 / **Focus** 31945000 /
Talis S 32475XXX / **Talis S** 32475003 / **Talis S** 72405000

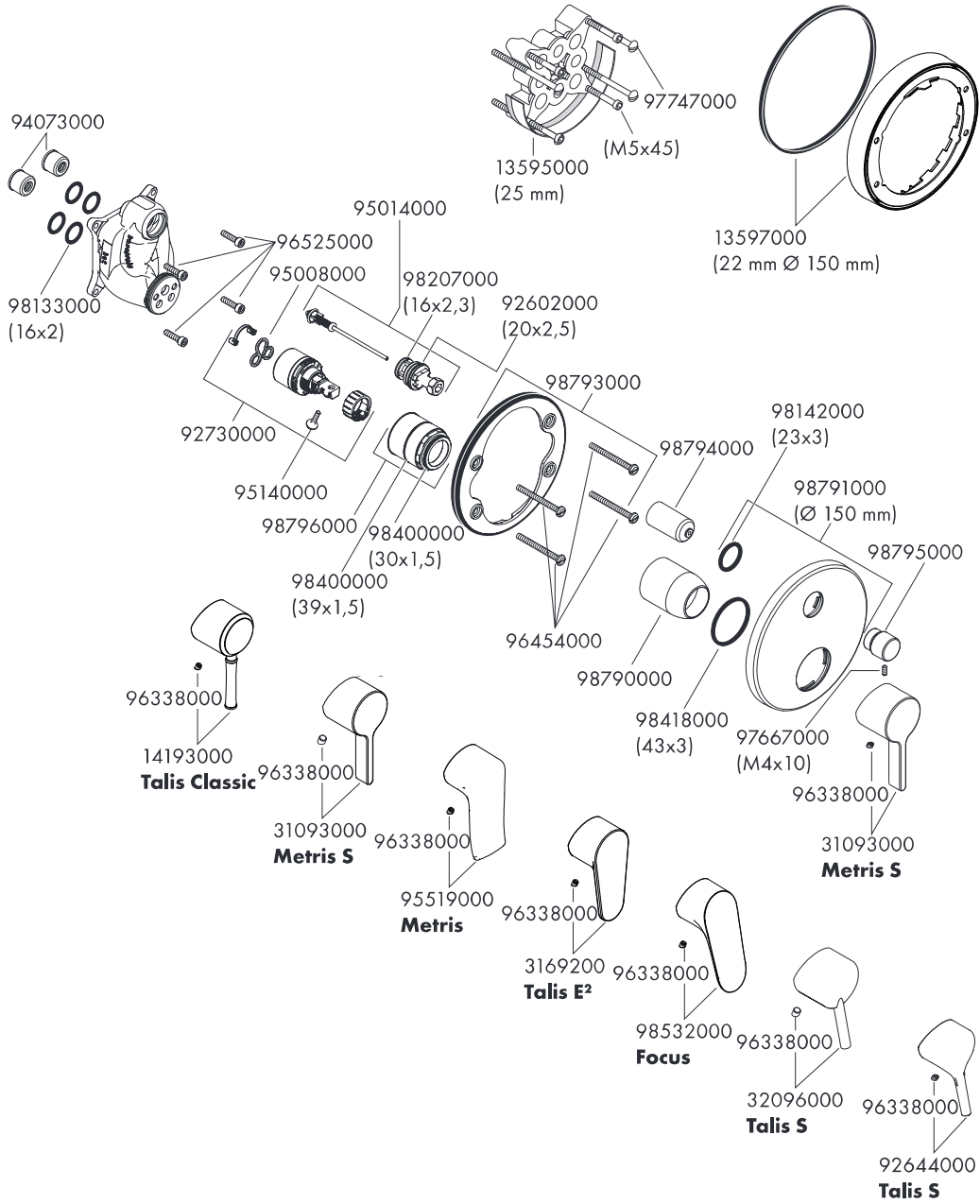



PuraVida 15445XXX / **Metropol Classic** 31345XXX / **Metris** 31454000 / **Metris Classic** 31485000 /
Logis Loop 71264000 / **Logis** 71405000 / **Talis E** 71745000

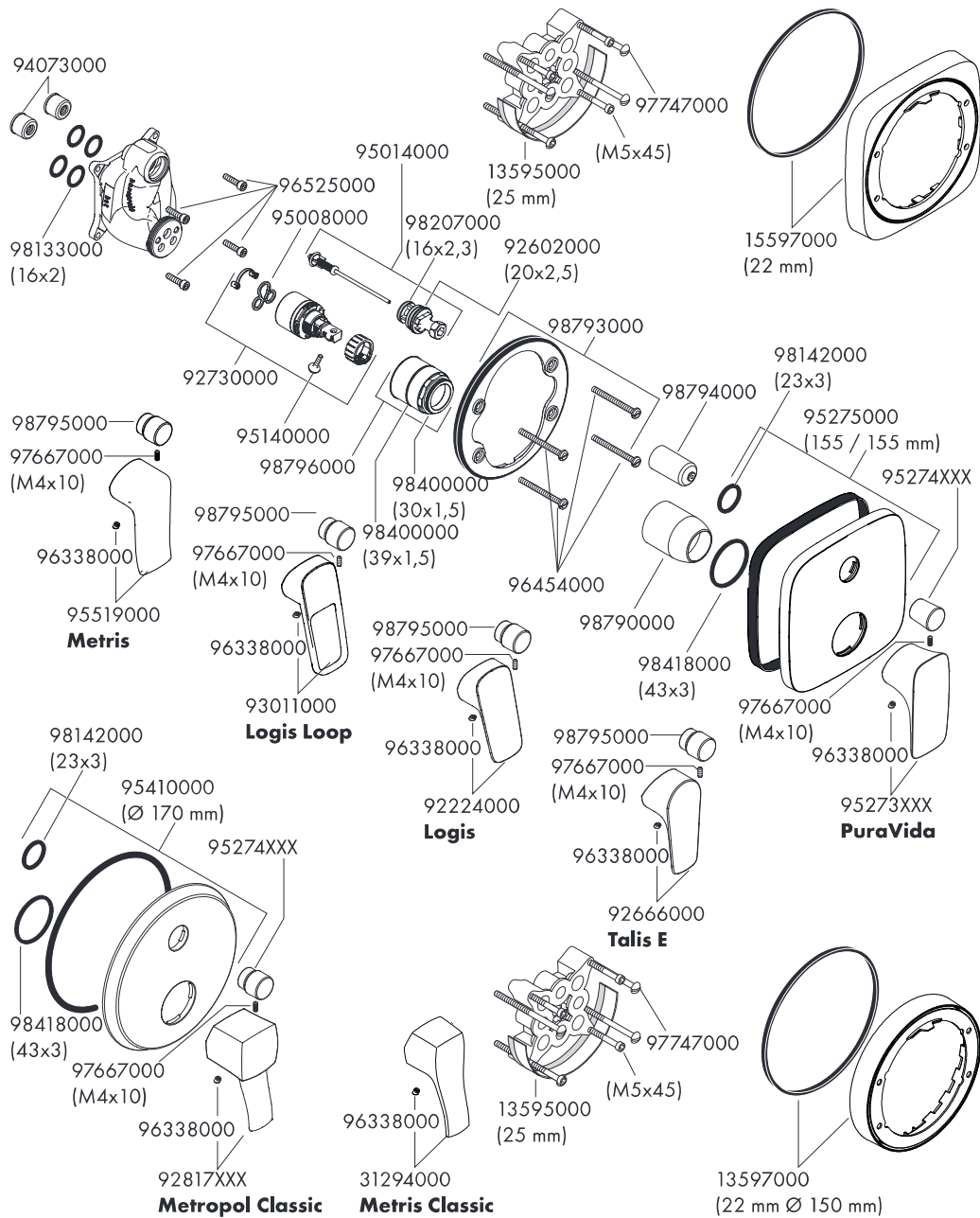



Metropol 32545000 / Metropol 74545000

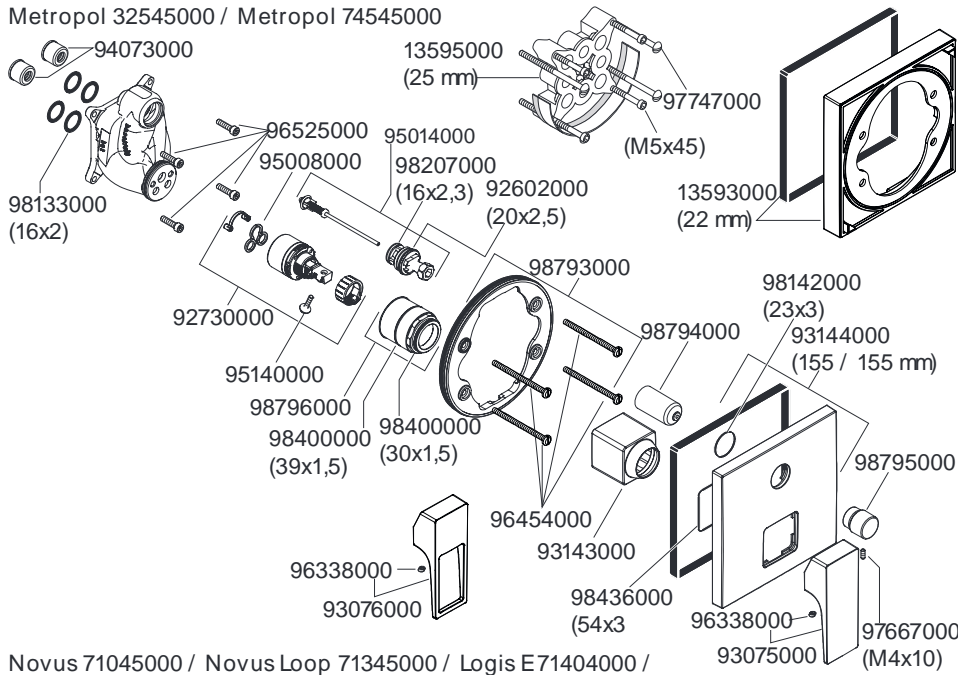

Novus 71045000 / Novus Loop 71345000 / Logis E71404000 /

