

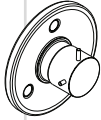

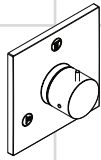

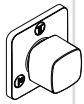



AXOR®

hansgrohe

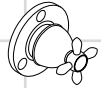
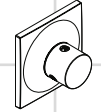
DE	Gebrauchsanleitung / Montageanleitung	2			
FR	Mode d'emploi / Instructions de montage	2			
EN	Instructions for use / assembly instructions	2			
IT	Istruzioni per l'uso / Istruzioni per Installazione	2			
ES	Modo de empleo / Instrucciones de montaje	3			
NL	Gebruiksaanwijzing / Handleiding	3			
DK	Brugsanvisning / Monteringsvejledning	3			
PT	Instruções para uso / Manual de Instalação	3			
PL	Instrukcja obsługi / Instrukcja montażu	4			
CS	Návod k použití / Montážní návod	4			
SK	Návod na použitie / Montážny návod	4			
ZH	用户手册 / 组装说明	4			
RU	Руководство пользователя / Инструкция по монтажу	5			
HU	Használati útmutató / Szerelési útmutató	5			
FI	Käyttöohje / Asennusohje	5			
SV	Bruksanvisning / Monteringsanvisning	5			
LT	Vartotojo instrukcija / Montavimo instrukcijos	6			
HR	Upute za uporabu / Uputstva za instalaciju	6			
TR	Kullanım kılavuzu / Montaj kılavuzu	6			
RO	Manual de utilizare / Instrucțiuni de montare	6			
EL	Οδηγίες χρήσης / Οδηγία συναρμολόγησης	7			
SL	Navodilo za uporabo / Navodila za montažo	7			
ET	Kasutusjuhend / Paigaldusjuhend	7			
LV	Lietošanas pamācība / Montāžas instrukcija	7			
SR	Uputstvo za upotrebu / Uputstvo za montažu	8			
NO	Bruksanvisning / Montasjeveiledning	8			
BG	Инструкция за употреба / Ръководство за монтаж	8			
SQ	Udhëzuesi i përdorimit / Udhëzime rreth montimit	8			
AR	دليل الاستخدام / تعليمات التجميع	9			
					
			Starck	Starck X	Urquiola
			10930000	10934000	11925000
					
			Montreux	Montreux	Carlton
			16830XXX	16832000	17920XXX
					
			Carlton	Massaud Bouroullec	
			17925XXX	18730000	19981000
					
			Bouroullec	Citterio M	Uno
			19982000	34920000	38933000
					
			Citterio	Citterio	
			39920000	39925000	

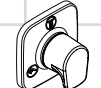
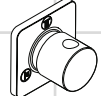

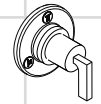
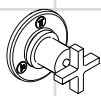
Sicherheitshinweise

- ⚠ Bei der Montage müssen zur Vermeidung von Quetsch- und Schnittverletzungen Handschuhe getragen werden.

Montagehinweise

Vor der Montage muss das Produkt auf Transportschäden untersucht werden. Nach dem Einbau werden keine Transport- oder Oberflächenschäden anerkannt.



Kein essigsäurehaltiges Silikon verwenden!



Maße (siehe Seite 13)



Serviceteile (siehe Seite 14)



Prüfzeichen (siehe Seite 16)

Montage
siehe Seite 10



Consignes de sécurité

- ⚠ Lors du montage, porter des gants de protection pour éviter toute blessure par écrasement ou coupure.

Instructions pour le montage

Avant son montage, s'assurer que le produit n'a subi aucun dommage pendant le transport. Après le montage, tout dommage de transport ou de surface ne pourra pas être reconnu.



Ne pas utiliser de silicone contenant de l'acide acétique!



Dimensions (voir page 13)



Pièces détachées (voir pages 14)



Classification acoustique et débit (voir page 16)

Montage
voir page 10



Safety Notes

- ⚠ Gloves should be worn during installation to prevent crushing and cutting injuries.

Installation Instructions

Prior to installation, inspect the product for transport damages. After it has been installed, no transport or surface damage will be honoured.



Do not use silicone containing acetic acid!



Dimensions (see page 13)



Spare parts (see page 14)



Test certificate (see page 16)

Assembly
see page 10

Indicazioni sulla sicurezza

- ⚠ Durante il montaggio, per evitare ferite da schiacciamento e da taglio bisogna indossare guanti protettivi.

Istruzioni per il montaggio

Prima del montaggio è necessario controllare che non ci siano stati danni durante il trasporto. Una volta eseguito il montaggio, non verranno riconosciuti eventuali danni di trasporto o delle superfici.



Non utilizzare silicone contenente acido acetico!



Ingombri (vedi pagg. 13)



Parti di ricambio (vedi pagg. 14)



Segno di verifica (vedi pagg. 16)

Montaggio
vedi pagg. 10



**! Indicaciones de seguridad**

- ⚠ Durante el montaje deben utilizarse guantes para evitar heridas por aplastamiento o corte.

Indicaciones para el montaje

Antes del montaje se debe examinarse el producto contra daños de transporte. Después de la instalación se reconoce ningún daño de transporte o de superficie.



No utilizar silicona que contiene ácido acético!



Dimensiones (ver página 13)



Repuestos (ver página 14)



Marca de verificación (ver página 16)

Montaje
ver página 10

**! Veiligheidsinstructies**

- ⚠ Bij de montage moeten ter voorkoming van knel- en snijwonden handschoenen worden gedragen.

Montage-instructies

Vóór de montage moet het product gecontroleerd worden op transportschade. Na de inbouw wordt geen transport- of oppervlakteschade meer aanvaard.



Gebruik geen zuurhoudende silicone!



Maten (zie blz. 13)



Service onderdelen (zie blz. 14)



Keurmerk (zie blz. 16)

Montage
zie blz. 10

**! Sikkerhedsanvisninger**

- ⚠ Ved monteringen skal der bruges handsker for at undgå kvæstelser og snitsår.

Monteringsanvisninger

Før monteringen skal produktet kontrolleres for transportskader. Efter monteringen godkendes transportskader eller skader på overfladen ikke længere.



Der må ikke benyttes eddikesyreholdig silikone!



Målene (se s. 13)



Reserve dele (se s. 14)



Godkendelse (se s. 16)

Montering
se s. 10

**! Avisos de segurança**

- ⚠ Durante a montagem devem ser utilizadas luvas de protecção, de modo a evitar ferimentos resultantes de entalamentos e de cortes.

Avisos de montagem

Antes da montagem deve-se controlar o produto relativamente a danos de transporte. Após a montagem não são aceites quaisquer danos de transporte ou de superfície.



Não utilizar silicone que contenha ácido acético!



Medidas (ver página 13)



Peças de substituição (ver página 14)



Marca de controlo (ver página 16)

Montagem
ver página 10



Wskazówki bezpieczeństwa

-  Aby uniknąć zranień, takich jak zgniecenia czy przecięcia, podczas montażu należy nosić rękawice.

Wskazówki montażowe

Przed montażem należy skontrolować produkt pod kątem szkód transportowych. Po montażu nie widać żadnych szkód transportowych ani szkód na powierzchni.



Nie stosować silikonów zawierających kwas octowy!



Wymiary (patrz strona 13)



Części serwisowe (patrz strona 14)



Znak jakości (patrz strona 16)

Montaż
patrz strona 10



Bezpečnostní pokyny

-  Pro zabránění řezným zraněním a pohmožděninám je nutné při montáži nosit rukavice.

Pokyny k montáži

Před montáží je třeba produkt zkontrolovat, zda nebyl při transportu poškozen. Po zabudování nebudou uznány žádné škody způsobené transportem nebo poškození povrchu.



Nepoužívat silikon s obsahem kyseliny octové!



Rozměry (viz strana 13)



Servisní díly (viz strana 14)



Zkušební značka (viz strana 16)

Montáž
viz strana 10



Bezpečnostné pokyny

-  Pri montáži musíte nosiť rukavice, aby ste predišli pomliaždeninám a rezným poraneniam.

Pokyny pre montáž

Pred montážou musíte produkt skontrolovať, či nebol počas transportu poškodený. Po zabudovaní nebudú uznané žiadne škody spôsobené transportom alebo poškodenia povrchu.



Nepoužívať silikon s obsahom kyseliny octovej!



Rozměry (vid' strana 13)



Servisné diely (vid' strana 14)



Osvedčenie o skúške (vid' strana 16)

Montáž
vid' strana 10

安全技巧

-  装配时为避免挤压和切割受伤，必须戴上手套。

安装提示

安装前必须检查产品是否受到运输损害。安装后将不认可运输损害或表面损伤。



请勿使用含有乙酸的硅！



大小 (参见第 13 页)



备用零件 (参见第 14 页)



检验标记 (参见第 16 页)

安装
参见第 10 页



Указания по технике безопасности

-  Во время монтажа следует надеть перчатки во избежание прищемления и порезов.

Указания по монтажу

Перед монтажом следует проверить изделие на предмет повреждений при перевозке. После монтажа претензии о возмещении ущерба за повреждения при перевозке или повреждения поверхностей не принимаются.



Не применяйте силикон, содержащий уксусную кислоту.



Размеры (см. стр. 13)



Комплект (см. стр. 14)



Знак технического контроля
(см. стр. 16)

Монтаж
см. стр. 10



Biztonsági utasítások

-  A szerelésnél a zúzódások és vágási sérülések elkerülése érdekében kesztyűt kell viselni.

Szerelési utasítások

A szerelés előtt ellenőrizni kell, hogy a terméknek nincs-e szállítási sérülése. Beépítés után a szállítási- vagy felületi sérüléseket nem ismerik el.



Ne használjon ecetsavtartalmú szilikon!



Méretet (lásd a 13. oldalon)



Tartozékok (lásd a 14. oldalon)



Vizsgajel (lásd a 16. oldalon)

Szerelés
lásd a 10. oldalon



Turvallisuusohjeet

-  Asennuksessa on käytettävä käsineitä puristumien ja viillojen aiheuttamien tapaturmien estämiseksi.

Asennusohjeet

Ennen asennusta on tarkastettava tuotteen mahdolliset kuljetusvahingot. Asennuksen jälkeen kuljetus- ja pintavaurioita ei hyväksytä.



Älä käytä etikkahappopitoista silikonial!



Mitat (katso sivu 13)



Varaosat (katso sivu 14)



Koestusmerkki (katso sivu 16)

Asennus
katso sivu 10



Säkerhetsanvisningar

-  Handskar ska bäras under monteringsarbetet så att man kan undvika kläm- och skärskadorna werden.

Monteringsanvisningar

Det måste undersökas om produkten har transportskador innan den monteras. Efter monteringen accepteras inga transport- eller ytskiktsskador.



Använd inte silikon som innehåller ättiksyra!



Måtten (se sidan 13)



Reservdelar (se sidan 14)



Testsigill (se sidan 16)

Montering
se sidan 10



Saugumo technikos nurodymai

-  Apsaugai nuo užspaudimo ir įsijpavimo montavimo metu mūvėkite pirštines.

Montavimo instrukcija

Prieš montuojant būtina patikrinti, ar gaminys nebuvo pažeistas transportavimo metu. Sumontavus pretenzijos dėl transportavimo ir paviršiaus pažeidimų nepriimamos.

Sigurnosne upute

-  Prilikom montaže se radi sprječavanja prignječenja i posjekotina moraju nositi rukavice.

Upute za montažu

Prije montaže mora se provjeriti je li proizvod oštećen prilikom transporta. Nakon ugradnje se ne priznaju nikakve reklamacije koje se odnose na površinska i transportna oštećenja.



Nenaudokite silikono, kurio sudėtyje yra acto rūgšties!

Išmatavimai (žr. psl. 13)



Atsarginės dalys (žr. psl. 14)



Bandymo pažyma (žr. psl. 16)



Montavimas
žr. psl. 10



Nemojte koristiti silikon koji sadrži octenu kiselinu!

Mjere (pogledaj stranicu 13)



Rezervni dijelovi (pogledaj stranicu 14)



Oznaka testiranja (pogledaj stranicu 16)



Sastavljanje
pogledaj stranicu 10



Güvenlik uyarıları

-  Montaj esnasında ezilme ve kesilme gibi yaralanmaları önlemek için eldiven kullanılmalıdır.

Montaj açıklamaları

Montaj işleminden önce ürün nakliye hasarları yönünden kontrol edilmelidir. Montaj işleminden sonra nakliye veya yüzey hasarları için sorumluluk üstlenilmemektedir.

Instrucțiuni de siguranță

-  La montare utilizați mănuși pentru evitarea contuziunilor și tăierii mâinilor.

Instrucțiuni de montare

Înainte de instalare verificați, dacă produsul prezintă deteriorări de transport. După instalare garanția nu acoperă deteriorările de transport și cele de suprafață.



Asetik asit içeren silikon kullanmayın!

Ölçüleri (Bakınız sayfa 13)



Yedek Parçalar (Bakınız sayfa 14)



Kontrol işareti (Bakınız sayfa 16)



Montajı
Bakınız sayfa 10



Nu utilizați silicon cu conținut de acid acetic!

Dimensiuni (vezi pag. 13)



Piese de schimb (vezi pag. 14)



Certificat de testare (vezi pag. 16)



Montare
vezi pag. 10



**⚠ Υποδείξεις ασφαλείας**

- ⚠ Για να αποφύγετε τραυματισμούς κατά τη συναρμολόγηση πρέπει να φοράτε γάντια.

Οδηγίες συναρμολόγησης

Πριν τη συναρμολόγηση πρέπει να εξεταστεί το προϊόν για ζημιές μεταφοράς. Μετά την εγκατάσταση δεν αναγνωρίζονται ζημιές από τη μεταφορά ή επιφανειακές ζημιές.



Μην χρησιμοποιείτε σιλικόνη που περιέχει οξικό οξύ!



Διαστάσεις (βλ. σελίδα 13)



Ανταλλακτικά (βλ. σελίδα 14)



Σήμα ελέγχου (βλ. σελίδα 16)

**Συναρμολόγηση
βλ. σελίδα 10**

⚠ Varnostna opozorila

- ⚠ Lors du montage, porter des gants de protection pour éviter toute blessure par écrasement ou coupure.

Navodila za montažo

Pred montažo je treba izdelek preveriti glede morebitnih transportnih poškodb. Po vgradnji transportne ali površinske poškodbe ne bodo več priznane.



Ne smete uporabiti silikona, ki vsebuje ocetno kislino!



Mere (glejte stran 13)



Rezervni deli (glejte stran 14)



Preskusni znak (glejte stran 16)

**Montaža
Glejte stran 10.**

**⚠ Ohutusjuhised**

- ⚠ Kandke paigaldamisel muljumis- ja löikevigastuste vältimiseks kindaid.

Paigaldamisjuhised

Enne paigaldamist tuleb toodet kontrollida transpordikahjustuste osas Pärast paigaldamist ei tunnustata enam transpordi- või pinnakahjustuste kaebuseid.



Ärge kasutage äädikhapet sisaldavat silikooni!



Mõõtude (vt lk 13)



Varuosad (vt lk 14)



Kontrollsertifikaat (vt lk 16)

**Paigaldamine
vt lk 10**

⚠ Drošības norādes

- ⚠ Montāžas laikā, lai izvairītos no saspiedumiem un iegriezumiem, nepieciešams nēsāt cimdus.

Norādījumi montāžai

Pirms montāžas nepieciešams pārbaudīt, vai produktam transportēšanas laikā nav radušies bojājumi. Pēc iebūvēšanas bojājumi, kas radušies transportēšanas laikā, vai virsmas bojājumi netiek atzīti.



Neizmantojiet silikonu, kas satur etiķskābi!



Izmērus (skat. 13. lpp.)



Rezerves daļas (skat. 14. lpp.)



Pārbaudes zīme (skat. 16. lpp.)

**Montāža
skat. 10. lpp.**





Sigurnosne napomene

-  Prilikom montaže se radi sprečavanja prignječenja i posekotina moraju nositi rukavice.

Instrukcije za montažu

Pre montaže se mora proveriti da li je proizvod oštećen pri transportu. Nakon ugradnje se ne priznaju nikakve reklamacije koje se odnose na površinska i transportna oštećenja.



Nemojte koristiti silikon koji sadrži sirćetnu kiselinu!



Mere (vidi stranu 13)



Rezervni delovi (vidi stranu 14)



Ispitni znak (vidi stranu 16)

**Montaža
vidi stranu 10**



Sikkerhetshenvisninger

-  Bruk hansker under montasjen for å unngå klem- og kuttskader.

Montagehenvisninger

Før montasjen skal produktet sjekkes for transportskader. Etter monteringen aksepteres ikke noen transport- eller overflateskader.



Ikke bruk silikon som inneholder eddiksyre!



Mål (se side 13)



Serviceleder (se side 14)



Prøvemerket (se side 16)

**Montasje
se side 10**



Указания за безопасност

-  При монтажа трябва да се носят ръкавици, за да се избегнат наранявания поради притискане или порязване.

Указания за монтаж

Преди монтажа продуктът трябва да се провери за транспортни щети. След монтажа не се признават транспортни или повърхностни щети.



Не използвайте силикон, съдържащ оцетна киселина!



Размери (вижте стр. 13)



Сервизни части (вижте стр. 14)



Контролен знак (вижте стр. 16)

**Монтаж
вижте стр. 10**



Udhëzime sigurie

-  Për të evituar lëndimet e pickimeve ose të prerjeve gjatë procesit të montimit duhet që të vishni doreza.

Udhëzime për montimin

Përpara montimit duhet që produkti të kontrollohet për dëmtime nga transporti. Pas instalimit nuk do të njihet asnjë dëmtim nga transporti ose dëmtim i sipërfaqes.



Mos përdorni silikon që në përbërje ka acid acetik.



Përmasat (shih faqen 13)



Pjesë ndërrimi (shih faqen 14)



Shenja e kontrollit (shih faqen 16)

**Montimi
shih faqen 10**



⚠️ تنبيهات الأمان

⚠️ يجب إرتداء قفازات لليد أثناء التركيب لتجنب حدوث أخطار الإنحشار أو الجروح.

تعليمات التركيب

قبل القيام بعملية التركيب. يجب فحص المنتج للتأكد من خلوه من أية تلفيات ناجمة عن النقل. بعد القيام بعملية التركيب. لن يتم الاعتراف بوجود أية تلفيات سطحية أو تلفيات ناجمة عن عملية النقل.

هام! لا تستخدم السليكون الذي يحتوي على أحماض!

أبعاد (راجع صفحة 13)

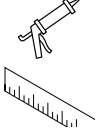

قطع الغيار (راجع صفحة 14)



شهادة اختبار (راجع صفحة 16)



التركيب راجع صفحة 10





Quattro
15930180

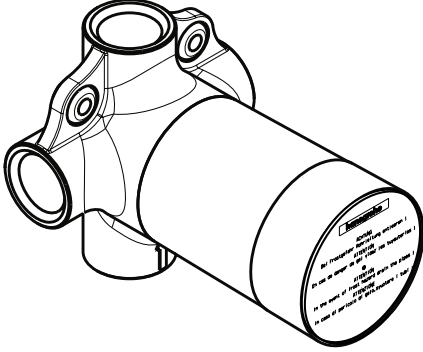

Trio
15981180

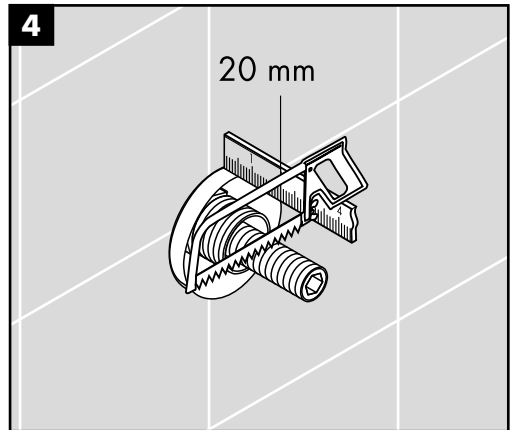
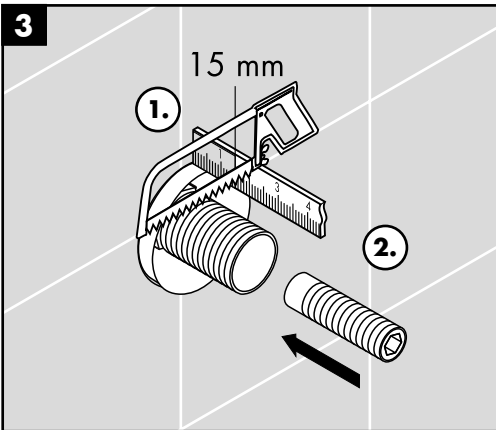
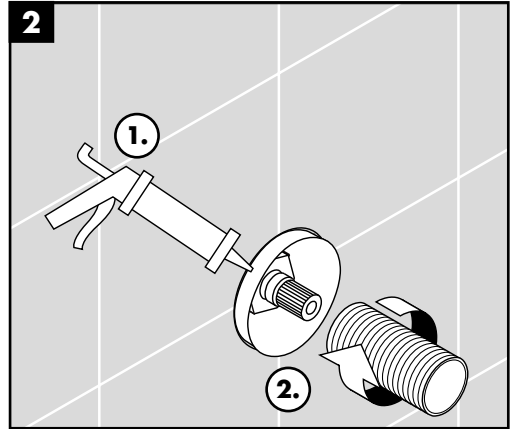
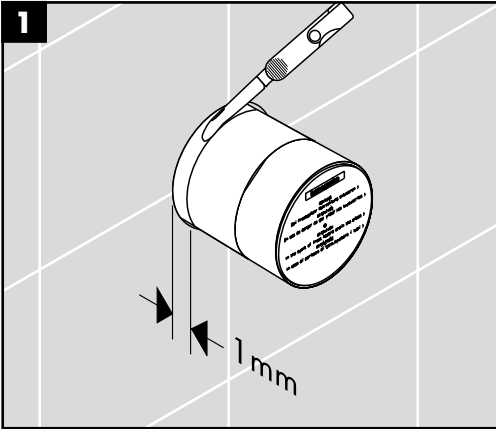
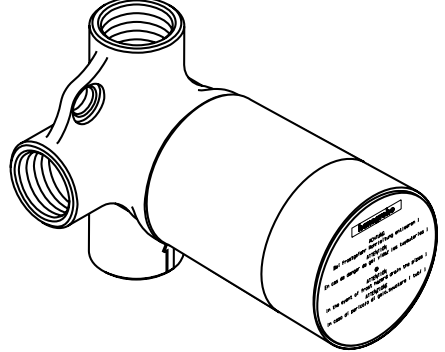

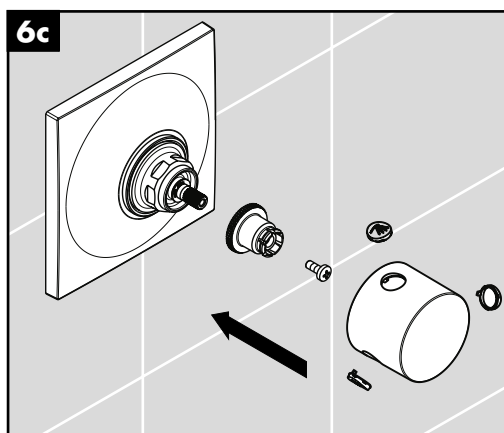
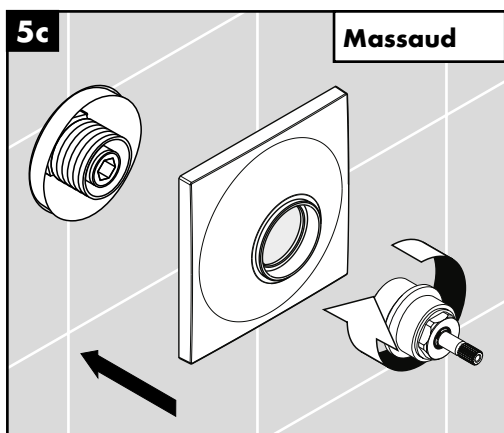
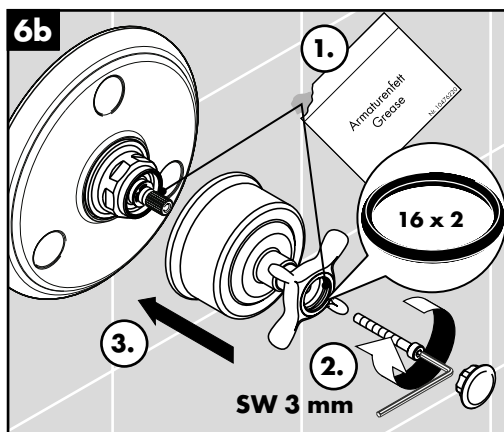
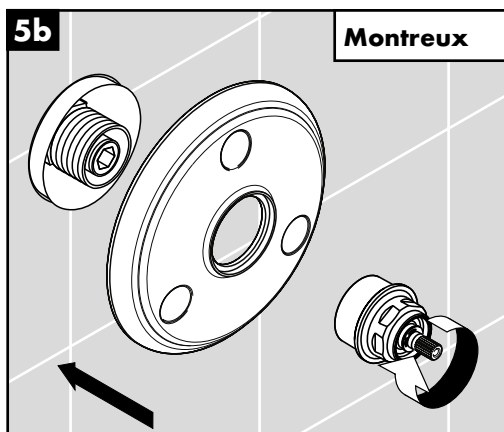
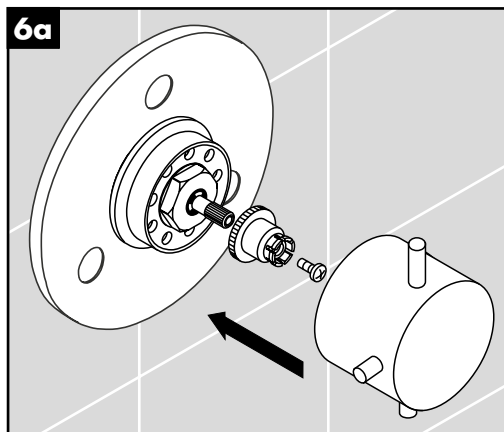
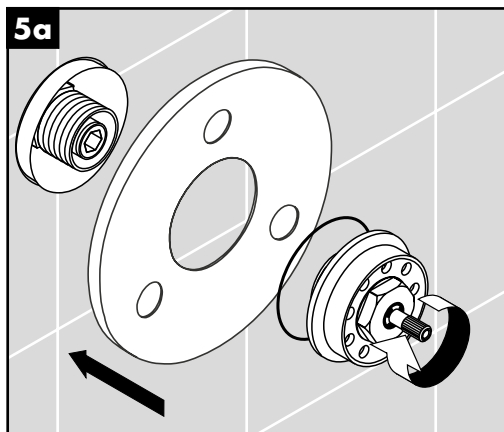

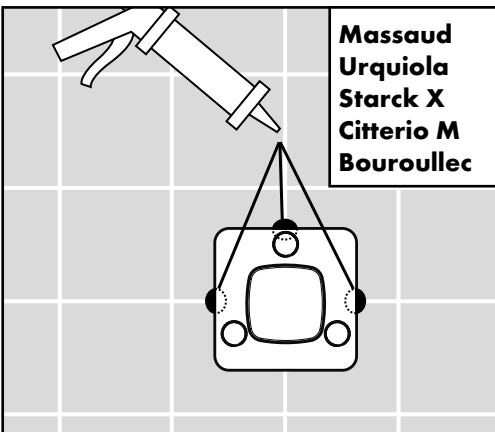
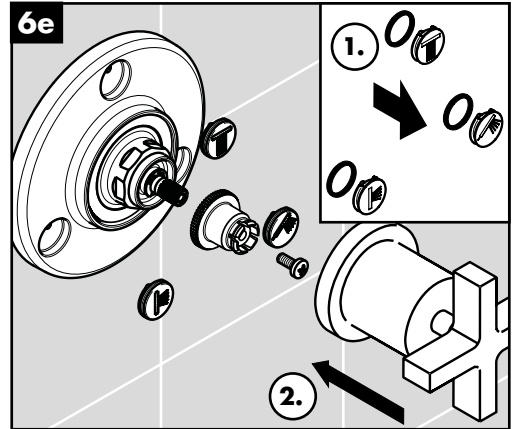
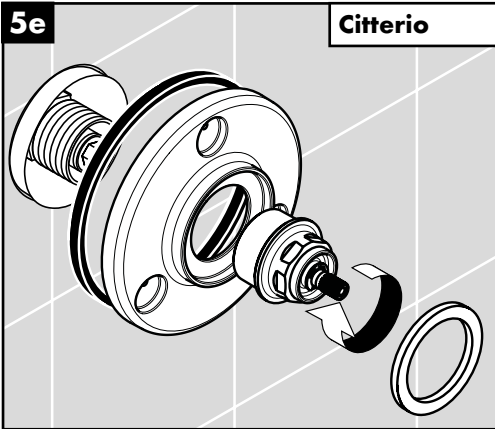
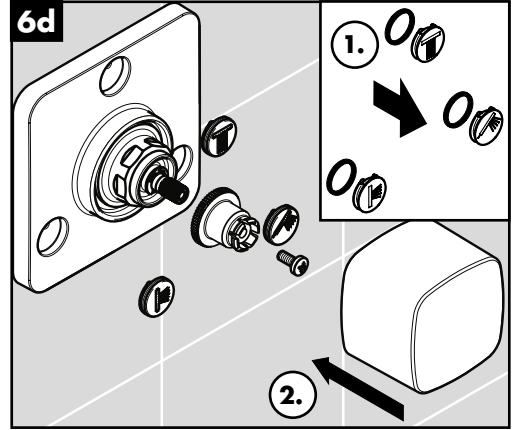
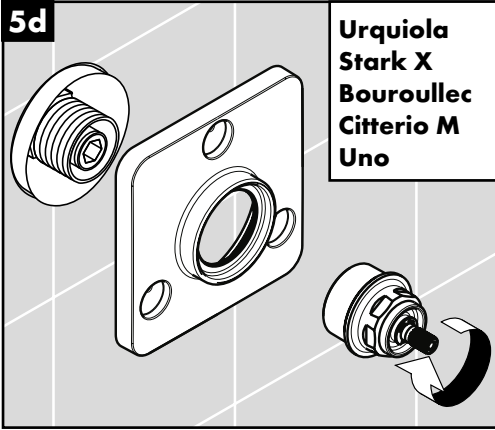

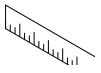

Starck
10930000

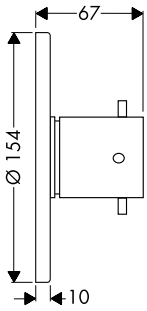

Starck X
10934000

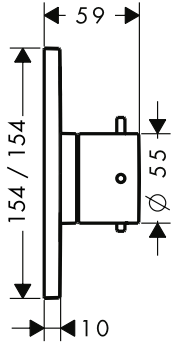

Urquiola
11925000

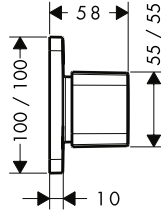

Montreux
16830XXX

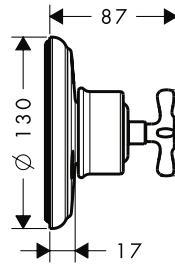

Montreux
16832000

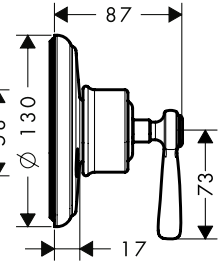

Carlton
17920XXX

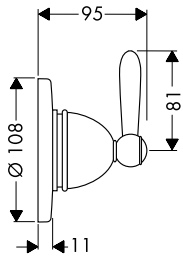

Carlton
17925XXX

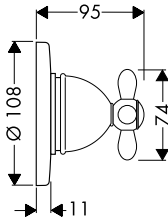

Massaud
18730000

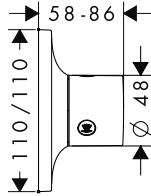

Bouroullec
19981000

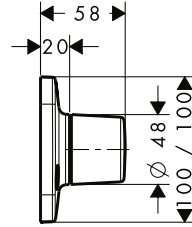

Bouroullec
19982000

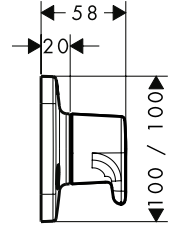

Citterio M
34920000

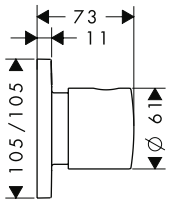

Uno
38933000

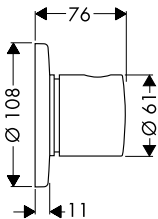

Citterio
39920000

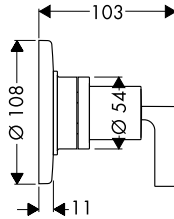

Citterio
39925000

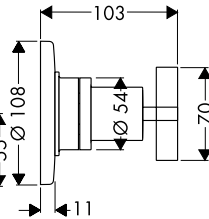

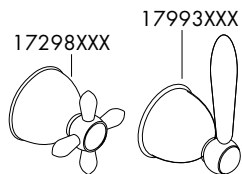
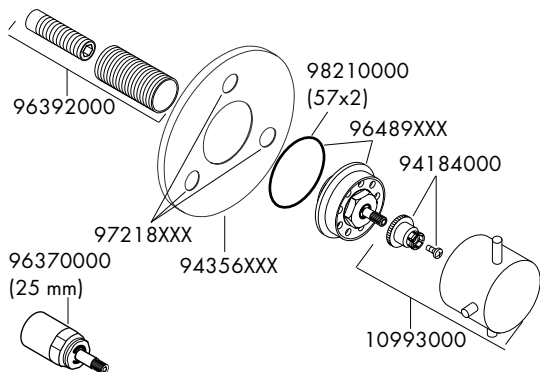

Starck X 10934000

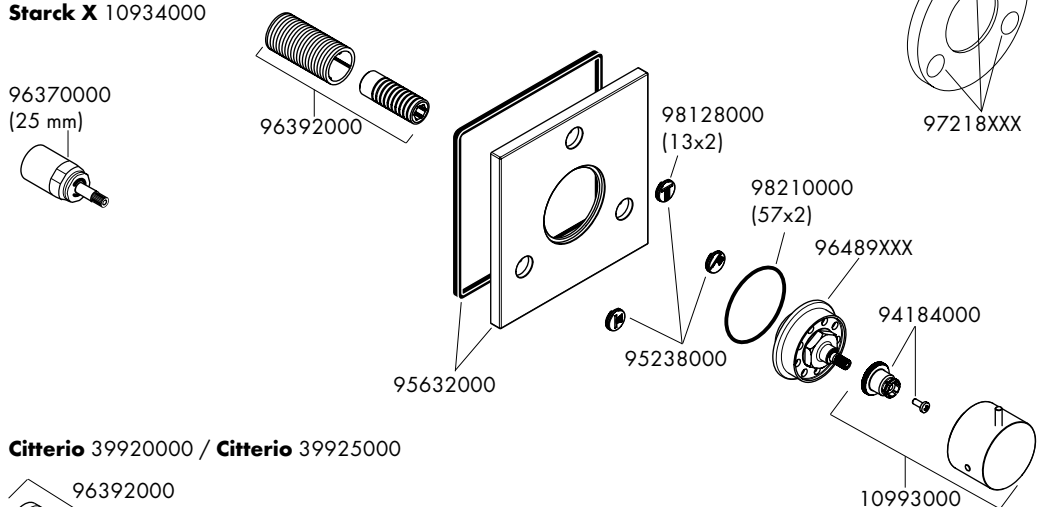

Citterio 39920000 / Citterio 39925000

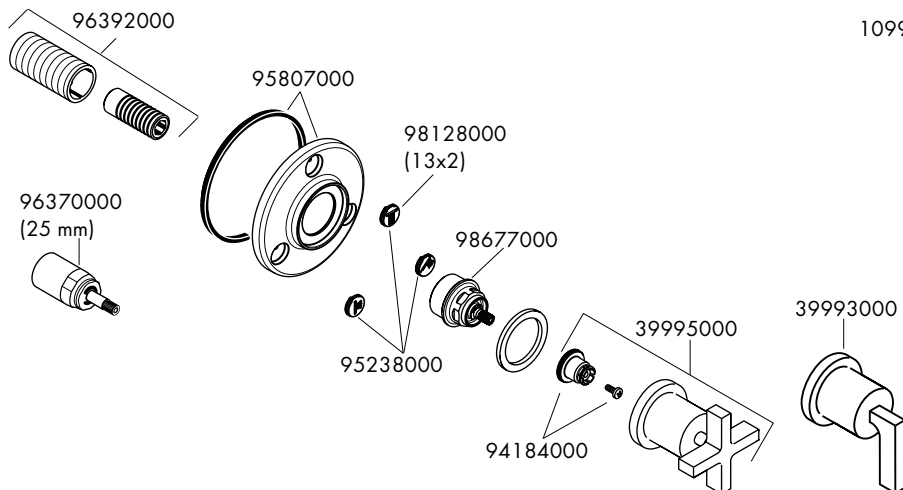

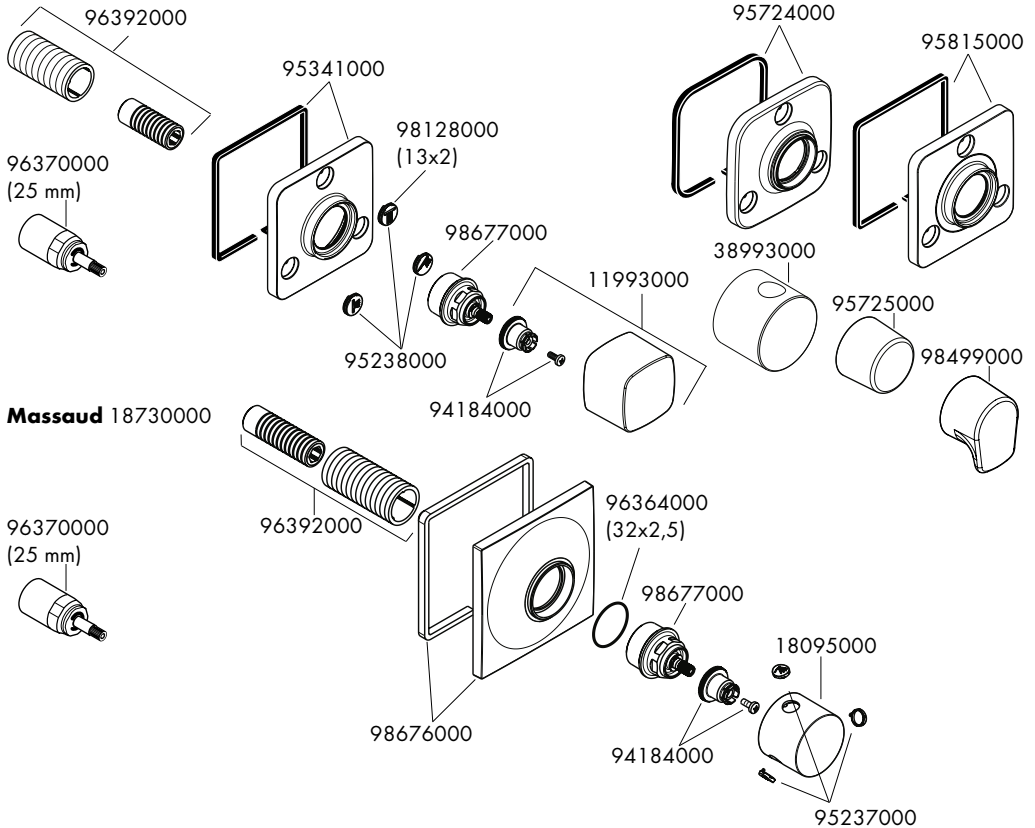
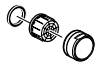

Massaud 18730000

96370000
(25 mm)

XXX = Farbcodierung // Couleurs // Colors // Trattamento // Acabados // Kleuren // Overflade // Acabamentos //
Kody kolorów // Kód povrchové úpravy // Farebné označenie // 颜色代码 // Цветная кодировка //
Színkódolás // Värikooodaus // Färgkodning // Spalvos // Boje // Renkler // Coduri de culori // Χρώματα //
الألوان // Barve // Värvid // Krāsū kodi // Oznake boja // Fargekode // Цветово кодирание // Kodimi me
anë të ngjyrave

000 = chrom // chromé // chrome plated // cromato // cromado // verchromd // Krom // cromado // chróm //
镀铬 // хром // króm // kromi // krom // crom // Επιχρωμιωμένο // كروم // kroom // hroma // hrom //
хром

090 = chrom/gold-optikk // chromé/or l'optique // chrome plated/gold plated // cromo/dorado ottica //
cromo/oro óptica // chroom/verguld-look // Krom/guld optic // cromado/ouro ótica //
chrom/złoty szlachetna // chrom/zlato ocel // chróm/zlato ocel // 镀铬/黑色 // хром/тлянцевоe золото //
króm/arany-hatású // kromi/kultaoptiikka // krom/guld-optikk // chrominè (aukso optika) //
optika krom/zlato // krom/altin-optikk // crom/auriu optic // Επιχρωμιωμένο/οπτική χρυσού //
كروم/لون ذهبي // krom/pozlačena // kroom/kuld optik // hroma/zelta // dezen hrom/zlatna //
krom/gull-optikk // хром/оптика за zlato // krom/i arte-optike

820 = brushed nickel // nikiel szorowany // 镍拉丝 // harjattu nikkeli // borstad nickel // nichel mat // νικελ ματ //
نيكل م فرش // børstet nikkel // надраскан никел // nikel i furçuar

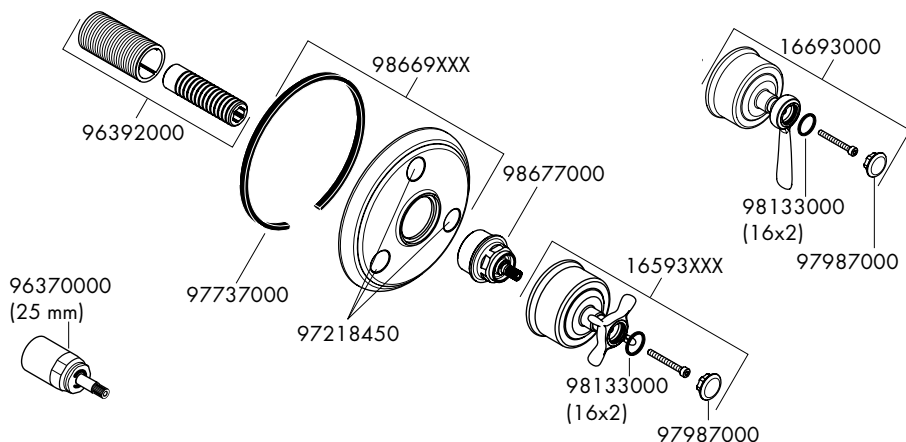

XXX = Farbcodierung // Couleurs // Colors // Trattamento // Acabados // Kleuren // Overflade // Acabamentos // Kody kolorów // Kód povrchové úpravy // Farebné označenie // 颜色代码 // Цветная кодировка // Színkódolás // Värikoodaus // Färgkodning // Spalvos // Boje // Renkler // Coduri de culori // Χρώματα // ناوأل // Barve // Värvid // Krāsu kodi // Oznake boja // Fargekode // Цветово кодиране // Kodimi me anë të ngjyrave

000 = chrom // chromé // chrome plated // cromato // cromado // verchromd // Krom // cromado // chróm // 镀铬 // хром // króm // kromi // krom // crom // Επιχρωμιωμένο // مورك // kroom // hroma // hrom // хром

820 = brushed nickel // nikiel szorowany // 镍拉丝 // harjattu nikkeli // borstad nickel // nichel mat // νικελ ματ // شَرْفَم لِكْيَن // børstet nikkel // надраскан никел // nikel i furçuar



	P-IX	DVGW	SVGW	ACS	WRAS	ETA	KIWA
10930000			X	X	X		
10934000					X		
11925000					X		
16830XXX			X	X	X		
16832000							
17920XXX			X	X	X		
17925XXX			X	X	X		
18730000			X	X	X		
19981000					X		
19982000							
34920000			X		X		
38933000			X	X	X		
39920000			X	X	X		
39925000			X	X	X		